

# IG-42HGM

41 & 42 TYPE

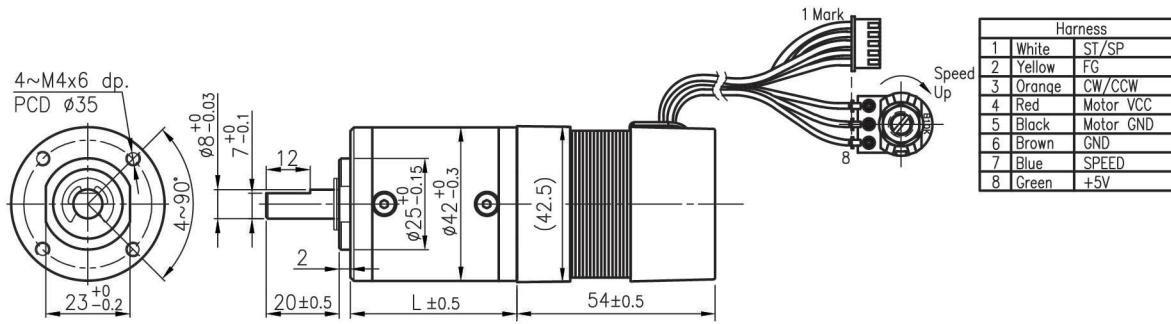

## 外形尺寸 / Appearance Size



unit:mm

## 齒輪箱馬達轉矩 & 速度 / Gear Motor Torque & Speed

	減速比 Reduction ratio	1/15	1/17	1/20	1/25	1/51	1/64	1/84	1/100	1/120	1/180	1/222	1/294	1/500	1/600	1/720	1/1062	1/1470	1/2500	1/3000	1/3600
12V	定格扭力 Rated torque (kgf-cm)	2.6	3.0	3.5	4.5	7.5	9.5	12.5	15	18	22.5	27.8	30	30	30	30	30	30	30	30	30
	定格轉速 Rated speed (rpm)	270	230	200	155	80	65	50	40	33	22	18	14.5	9.1	7.8	6.6	4.5	3.3	2.0	1.6	1.4
24V	定格扭力 Rated torque (kgf-cm)	3.9	4.5	5.2	6.4	11.5	14.5	18.6	22	26.6	28	30	30	30	30	30	30	30	30	30	30
	定格轉速 Rated speed (rpm)	280	245	210	170	80	65	50	42	35	24	20	15.5	9.6	8.0	6.8	4.6	3.4	2.0	1.7	1.4
	長度 Length (L)	39.2			45.9			52.6			59.6										

## 馬達單體型式 / Motor Data

定格電壓 Rated volt (V)	定格扭力 Rated torque (gf-cm)	定格轉速 Rated speed (rpm)	定格電流 Rated current (A)	無負荷轉速 No load speed (rpm)	無負荷電流 No load current (A)	定格出力 Rated output (W)	重量 Weight (g)
12	250	4000	≤ 1.6	5000	≤ 0.3	10.5	250
24	370	4200	≤ 1.1	5000	≤ 0.25	16.2	250

## 馬達單體特性 / Motor Characteristics

