

IG-38PGM

01 & 02 TYPE

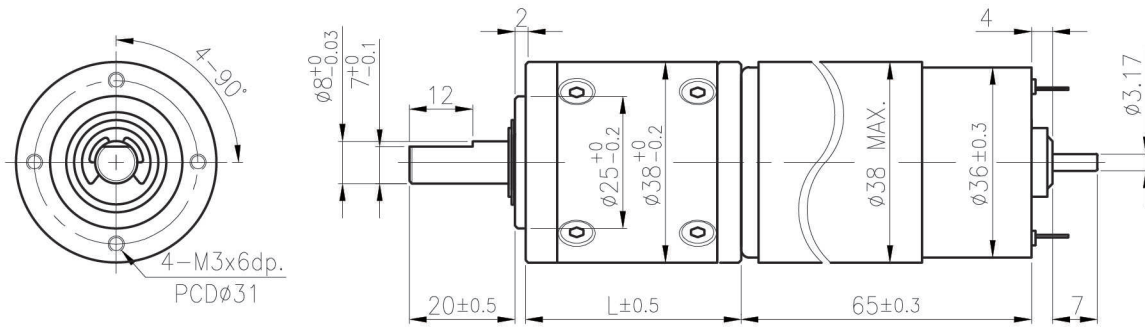

外形尺寸/ Appearance Size



unit:mm

齒輪箱馬達轉矩 & 速度/ Gear Motor Torque & Speed

減速比 Reduction ratio	1/5	1/14	1/19	1/27	1/51	1/71	1/100	1/139	1/189	1/264	1/516	1/721	
12V 定格扭力 Rated torque (kgf-cm)	1	2.4	3.3	4.7	7.6	10	15	20	23	25	30	30	
12V 定格轉速 Rated speed (rpm)	1100	420	300	210	110	81	58	41	30	22.5	11.6	8.4	
24V 定格扭力 Rated torque (kgf-cm)	1.1	2.7	3.7	5.2	8.5	12	16	20	25	25	30	30	
24V 定格轉速 Rated speed (rpm)	1050	390	280	200	105	76	55	41	29	22.5	11.6	8.4	
軸心迴轉方向 Rotation direction	CCW												
長度 Length (L)	33.1		41.8			50.5			59.2				

馬達單體型式/ Motor Data

定格電壓 Rated volt (V)	定格扭力 Rated torque (gf-cm)	定格轉速 Rated speed (rpm)	定格電流 Rated current (A)	無負荷轉速 No load speed (rpm)	無負荷電流 No load current (A)	定格出力 Rated output (W)	重量 Weight (g)
12	250	5800	≤1.6	6400	≤0.3	14.89	264
24	280	5500	≤0.9	6400	≤0.16	15.81	266

馬達單體特性/ Motor Characteristics

