

IG

# IG-22CGM

## 01 & 02 TYPE



### 外形尺寸/ Appearance Size

視圖方向僅供參考 / The position of the screw hole and motor terminal in the photo is only for reference.

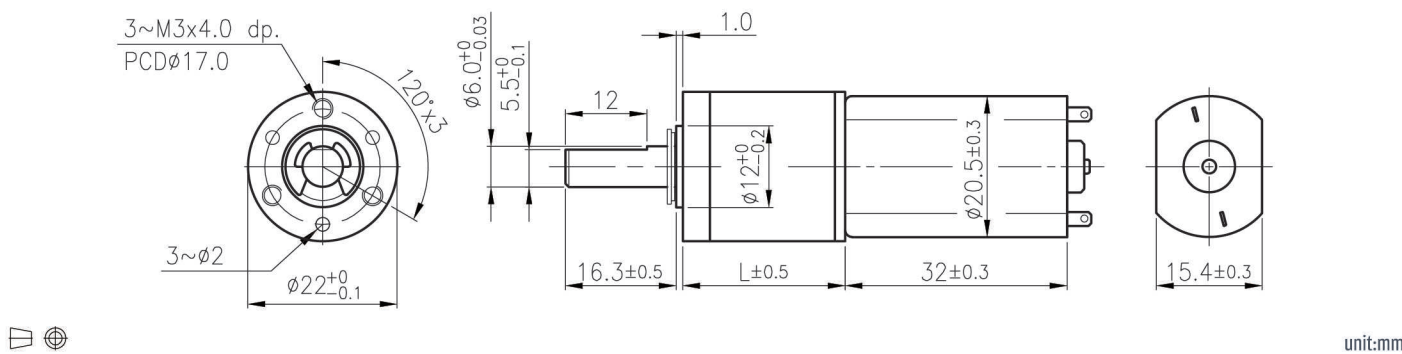

### 齒輪箱馬達轉矩 & 速度/ Gear Motor Torque & Speed

減速比 Reduction ratio	1/5	1/18	1/20	1/25	1/66	1/77	1/90	1/110	1/136	1/246	1/336	1/393	1/484	1/597	1/735	1/1079	1/1475	1/2124	1/3968
12V 定格扭力 Rated torque (gf-cm)	80	270	310	380	850	1000	1150	1400	1700	2600	3700	4200	5000	5000	5000	6000	6000	6000	6000
12V 定格轉速 Rated speed (rpm)	1400	375	325	260	101	86	74	60	48	26	19	16	13.8	11.5	9.5	6.7	5	3.4	1.8
24V 定格扭力 Rated torque (gf-cm)	80	270	310	380	850	1000	1150	1400	1700	2600	3700	4200	5000	5000	5000	6000	6000	6000	6000
24V 定格轉速 Rated speed (rpm)	1550	414	355	290	110	95	82	66	53	29	21	18	15.3	12.7	10.5	7.4	5.5	3.9	1.95
軸心迴轉方向 Rotation direction	CCW																		
長度 Length (L)	23.3		29.5		35.7				41.9				48.1						

### 馬達單體型式/ Motor Data

定格電壓 Rated volt (V)	定格扭力 Rated torque (gf-cm)	定格轉速 Rated speed (rpm)	定格電流 Rated current (mA)	無負荷轉速 No load speed (rpm)	無負荷電流 No load current (mA)	定格出力 Rated output (W)	重量 Weight (g)
12	22	6700	≤ 200	8000	≤ 70	1.5	32
24	22	7400	≤ 110	9000	≤ 40	1.7	32

### 馬達單體特性/ Motor Characteristics

