

IG-16GM

04 & 05 TYPE



外形尺寸/ Appearance Size

視圖方向僅供參考 / The position of the screw hole and motor terminal in the photo is only for reference.

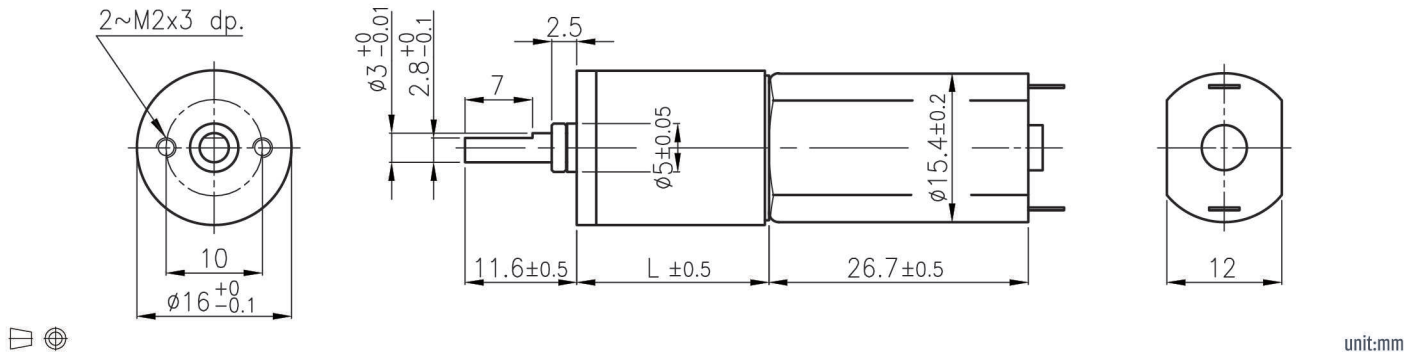

齒輪箱馬達轉矩 & 速度/ Gear Motor Torque & Speed

減速比 Reduction ratio	1/4	1/14	1/16	1/19	1/29	1/53	1/62	1/72	1/84	1/104	1/128	1/157	1/231	1/316	1/370	1/455	1/561	1/690	1/1014	1/1621	1/1996	1/3027
12V 定格扭力 Rated torque (gf-cm)	21	60	70	82	120	193	220	260	300	380	460	550	700	950	1100	1350	1700	2000	2400	2400	2400	2400
12V 定格轉速 Rated speed (rpm)	1330	430	377	315	205	117	100	85	73	59	48	39	26	19	16	13.5	11	8.9	6	3.8	3.2	2.3
24V 定格扭力 Rated torque (gf-cm)	31	85	103	120	180	284	330	380	450	560	690	850	1000	1400	1600	2000	2000	2400	2400	2400	2400	2400
24V 定格轉速 Rated speed (rpm)	2400	760	669	555	365	208	170	150	130	105	85	69	47	34	29	24	19.5	15.9	11	7.2	6.1	4.1
軸心迴轉方向 Rotation direction	CW																					
長度 Length (L)	15.05		18.70				22.35				26				29.65							

馬達單體型式/ Motor Data

定格電壓 Rated volt (V)	定格扭力 Rated torque (gf-cm)	定格轉速 Rated speed (rpm)	定格電流 Rated current (mA)	無負荷轉速 No load speed (rpm)	無負荷電流 No load current (mA)	定格出力 Rated output (W)	重量 Weight (g)
12	6.1	6200	≤ 85	8000	≤ 50	0.394	18
24	9	11000	≤ 90	13500	≤ 50	1.026	18

馬達單體特性/ Motor Characteristics

