

# Planetary Gearbox & Gear Motor

IG series

Right Angle series

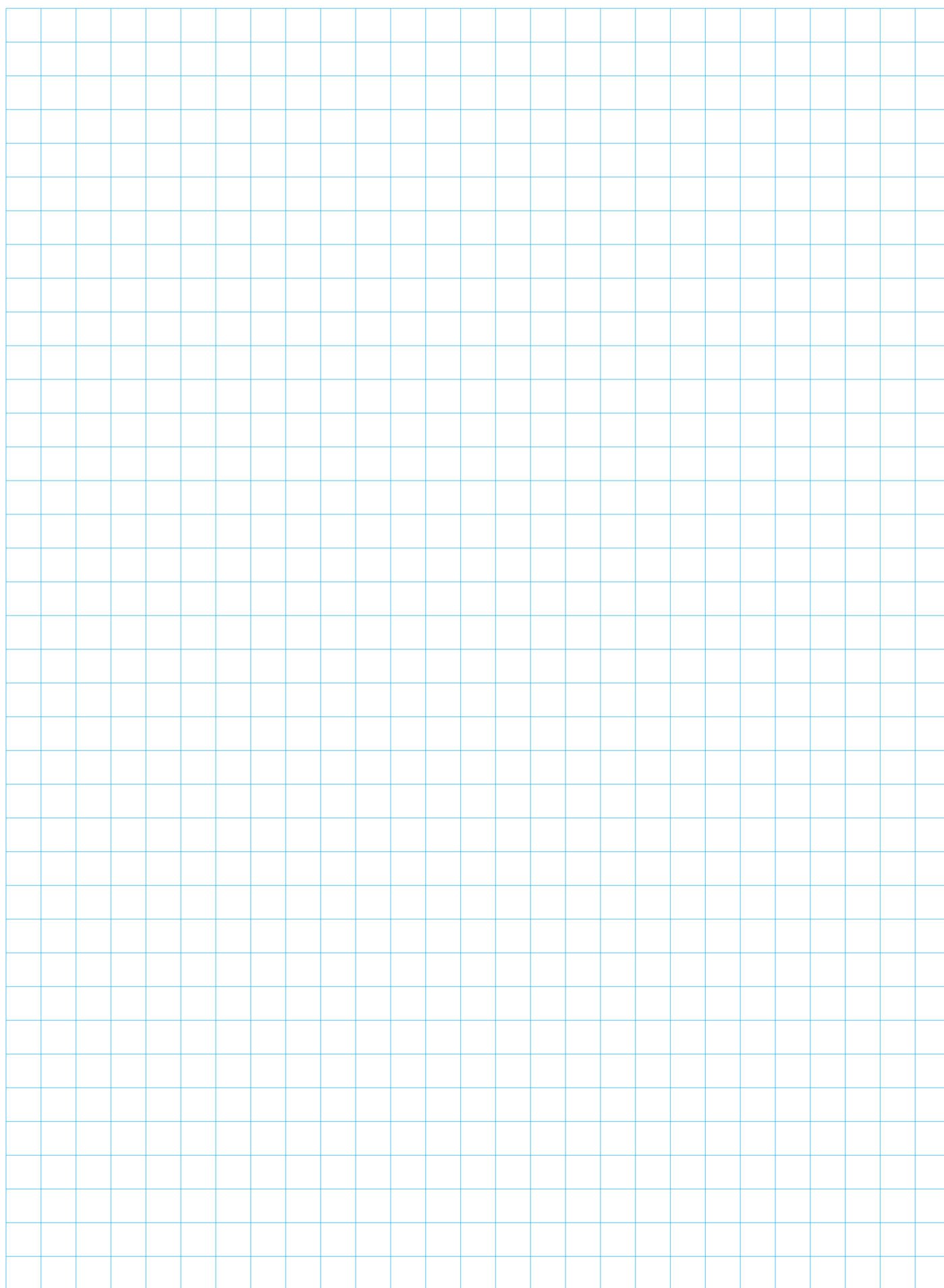



# 行星式齒輪箱

## PLANETARY GEARBOX

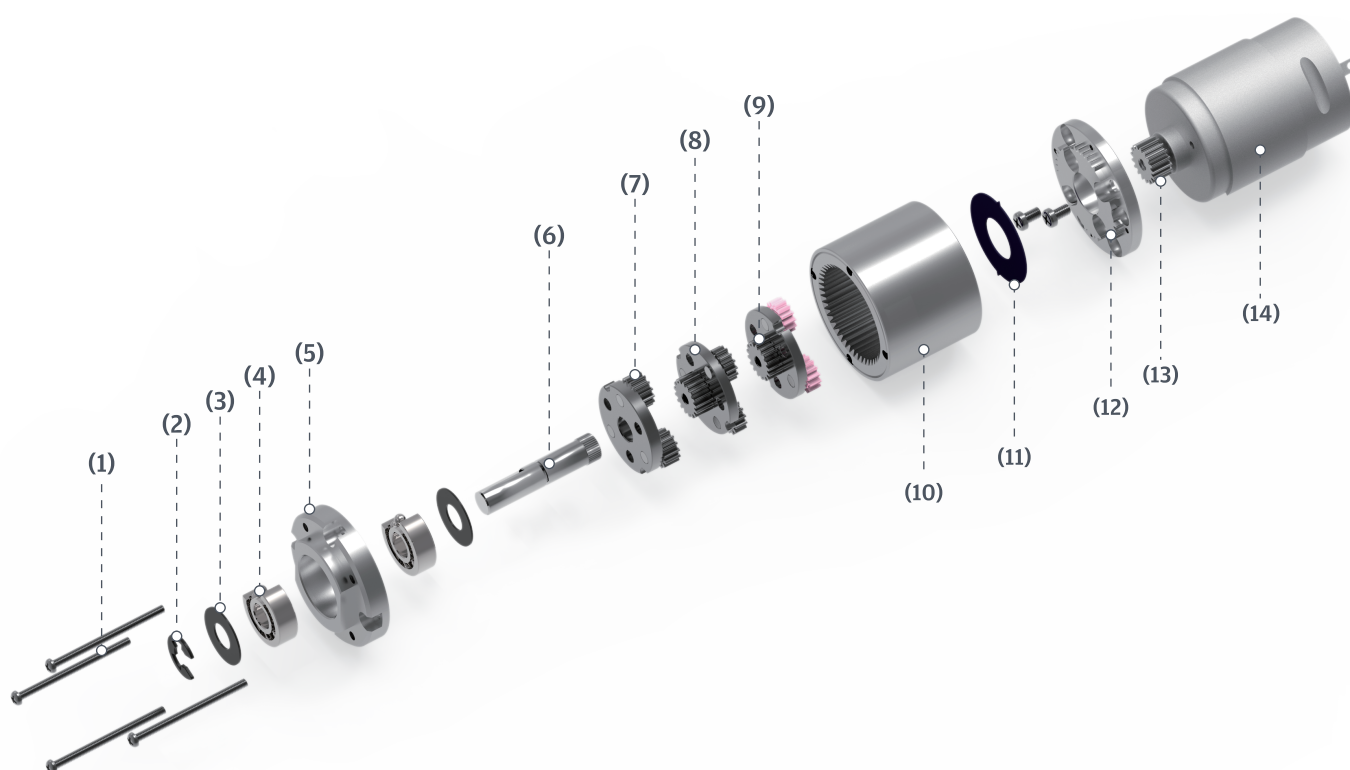

1	螺絲	Screw	8	傳動齒盤	Satellite carrier
2	扣環	Circlip	9	中心齒輪	Sun gear
3	墊片	Washer	10	外殼/內齒輪	Housing/ring gear
4	滾珠軸承	Ball bearing	11	墊片	Washer
5	上蓋	Front cover	12	下蓋	Motor flange
6	主軸	Output shaft	13	馬達齒	Pinion
7	行星齒輪	Satellite gear	14	馬達	Motor

# 行星式齒輪箱 PLANETARY GEARBOX

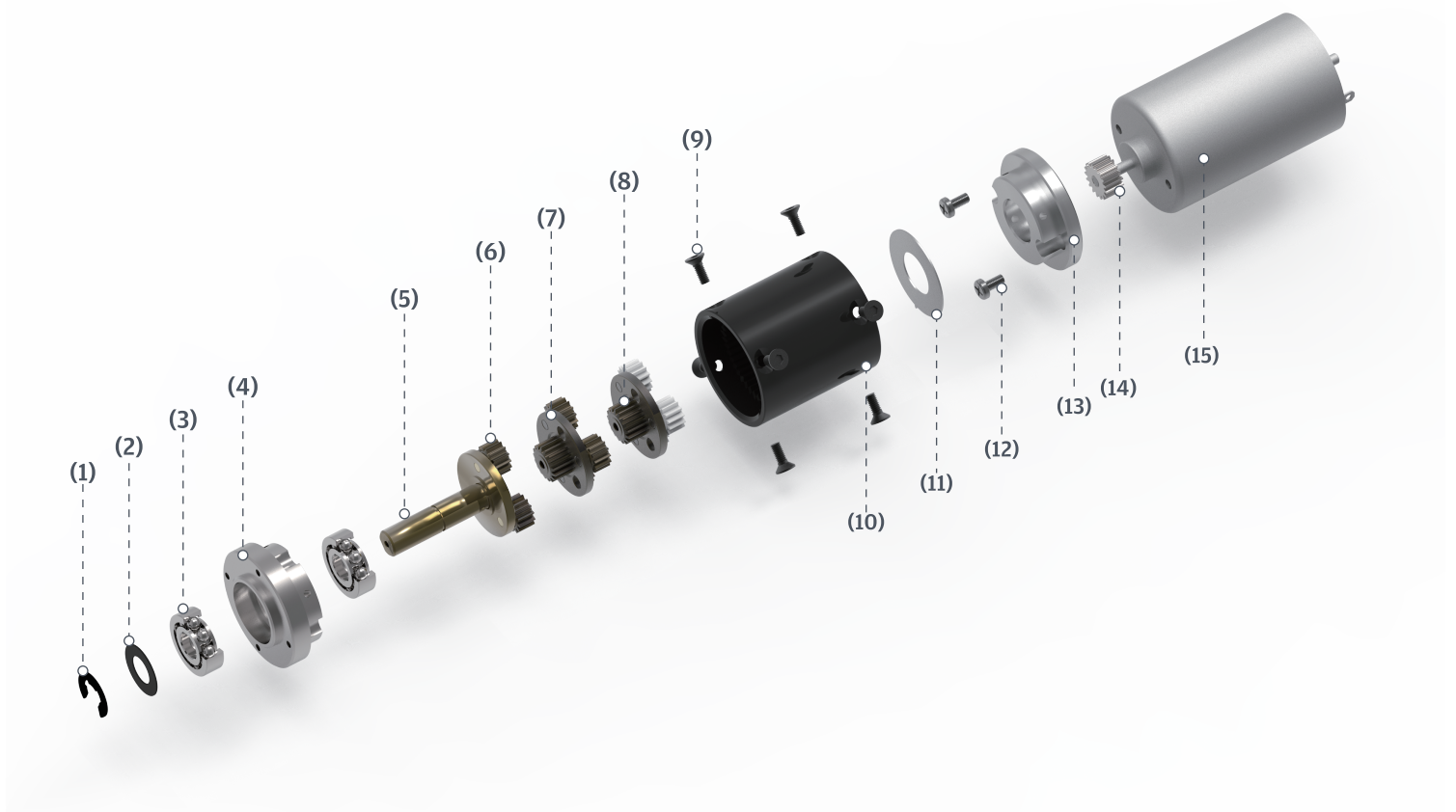

1	扣環	Circlip
2	墊片	Washer
3	滾珠軸承	Ball bearing
4	上蓋	Front cover
5	主軸	Output shaft
6	行星齒輪	Satellite gear
7	傳動齒盤	Satellite carrier
8	中心齒輪	Sun gear

9	螺絲	Screw
10	外殼/內齒輪	Housing/ring gear
11	墊片	Washer
12	螺絲	Screw
13	下蓋	Motor flange
14	馬達齒	Pinion
15	馬達	Motor

IG

# IG-08



Right Angle

## 外形尺寸 & 馬達齒啮合尺寸 / Appearance Size & Pinion Assembly Dimension

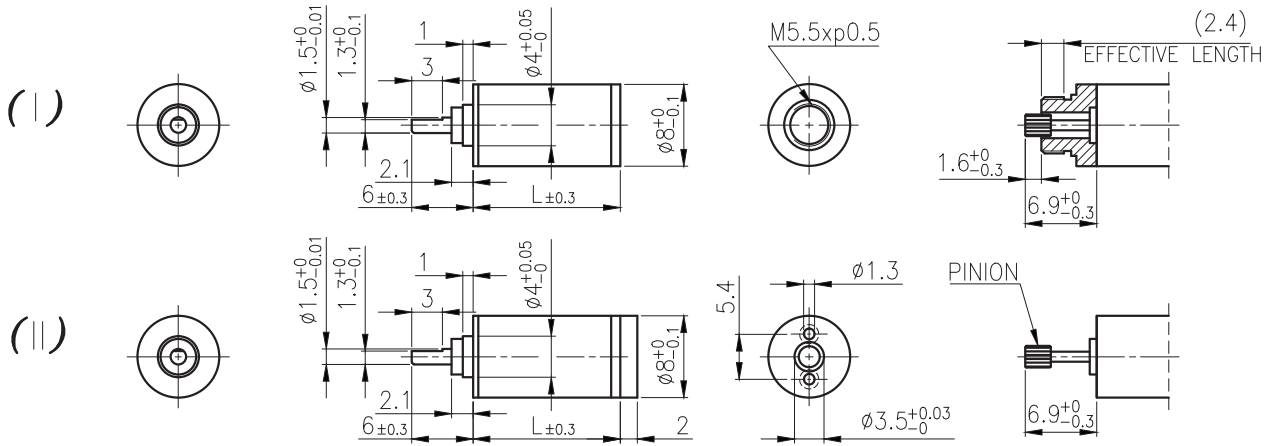

unit:mm

RA

RB

## 產品規格 / Product Specifications

外殼材質 Housing material	輸出軸承型式 Output shaft bearing	徑向負荷 Radial load (5mm from flange)	軸向負荷 Shaft axial load	主軸承受壓入力 Shaft press fit force	徑向間隙 Radial play of shaft	軸向間隙 Thrust play of shaft	背隙 (無負荷時) Backlash, at no-load
金屬 Metal	含油軸承 Sleeve bearing	≤ 80 gf	≤ 100 gf	≤ 500 gf	≤ 0.05 mm	≤ 0.2 mm	≤ 3°

WG

## 馬達齒輪型式 / Pinion Specification

模數 Module	齒數 No. of teeth	壓力角 Pressure angle	孔徑 (mm) Hole diameter	減速比 Reduction ratio
0.16	12	20°	∅ 0.99	全機種通用 Practicable

PG

## 標準減速比型式 / Gearboxes Specifications

減速比 Reduction ratio	1/4	1/16	1/64	1/256	1/1024	1/4096								
定額容許扭力 (gf-cm max.) Rated tolerance torque	50	100	200	300	350	400								
瞬間容許扭力 (gf-cm) Max momentary tolerance torque	150	300	600	900	1050	1200								
效率 Efficiency	85%	75%	65%	55%	45%	40%								
長度 Length (L)	9.6	12.3	15	17.7	20.4	23.1								
重量 (I) Weight (g)	2.9	3.8	4.6	5.4	6.3	7.1								
重量 (II) Weight (g)	3.7	4.6	5.4	6.2	7.1	7.9								

Encoder

Driver

- 使用相對溼度：20%~85%RH  
Operating relative humidity
- 使用溫度範圍：-10°C~+60°C  
Operating temperature range



# IG-08GM

## 01 & 02 TYPE



### 外形尺寸/ Appearance Size

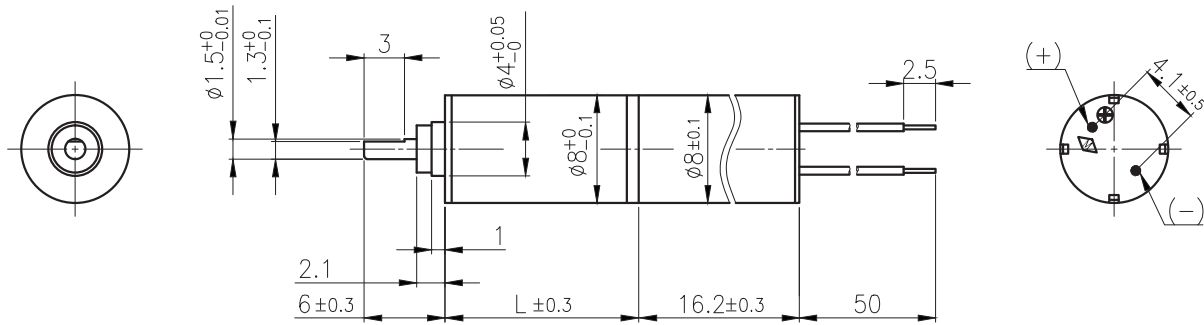

unit:mm

### 齒輪箱馬達轉矩 & 速度/ Gear Motor Torque & Speed

減速比 Reduction ratio		1/4	1/16	1/64	1/256	1/1024	1/4096								
3V	定格扭力 Rated torque (gf-cm)	6.8	24	83	281	350	400								
	定格轉速 Rated speed (rpm)	2250	562	140	35	10	2.9								
6V	定格扭力 Rated torque (gf-cm)	6.8	24	83	281	350	400								
	定格轉速 Rated speed (rpm)	2875	719	179	44	12.6	3.3								
軸心迴轉方向 Rotation direction		CW													
長度 Length (L)		9.6	12.3	15	17.7	20.4	23.1								

### 馬達單體型式/ Motor Data

定格電壓 Rated volt (V)	定格扭力 Rated torque (gf-cm)	定格轉速 Rated speed (rpm)	定格電流 Rated current (mA)	無負荷轉速 No load speed (rpm)	無負荷電流 No load current (mA)	定格出力 Rated output (W)	重量 Weight (g)
3	2	9000	≤150	12500	≤30	0.18	3.7
6	2	11500	≤110	14700	≤20	0.23	7.2

### 馬達單體特性/ Motor Characteristics

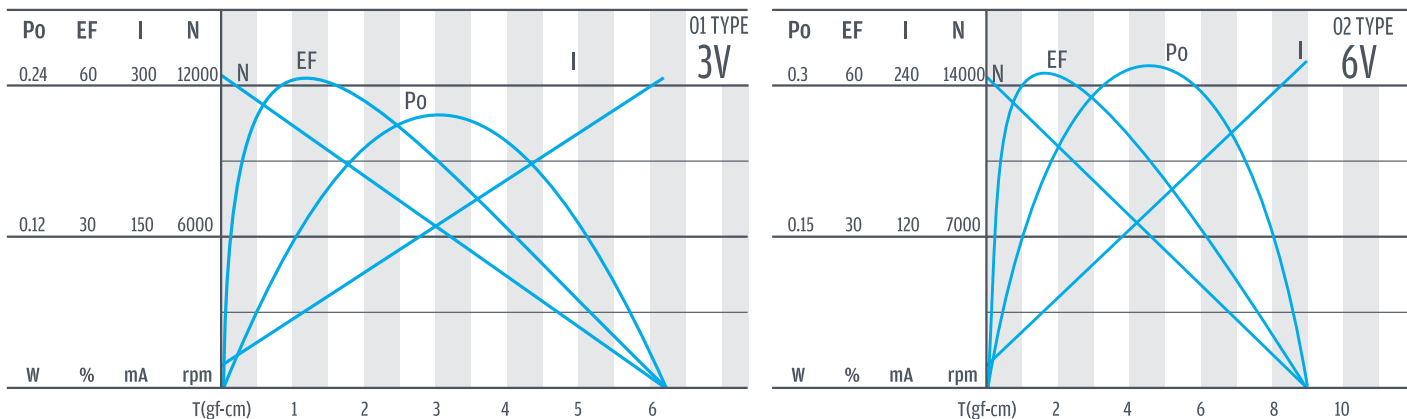

IG

# IG-08GM

## 03 TYPE



Right Angle

### 外形尺寸 / Appearance Size

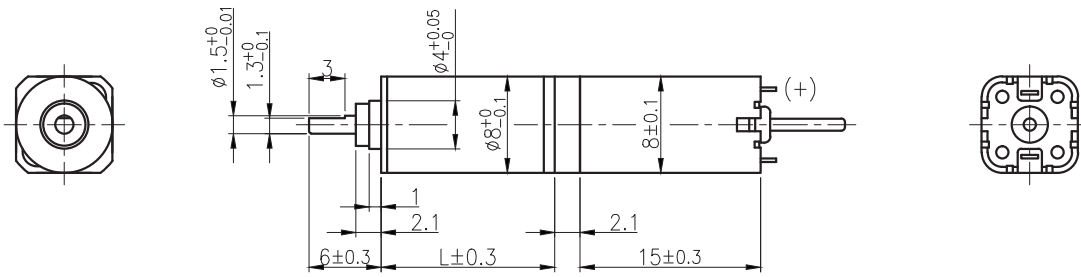

unit:mm

RA

### 齒輪箱馬達轉矩 & 速度 / Gear Motor Torque & Speed

	減速比 Reduction ratio	1/4	1/16	1/64	1/256	1/1024	1/4096							
3V	定格扭力 Rated torque (gf-cm)	5	17.5	62	210	350	400							
	定格轉速 Rated speed (rpm)	1400	350	87	21.9	6.7	1.8							
	軸心迴轉方向 Rotation direction	CW												
	長度 Length (L)	9.6	12.3	15	17.7	20.4	23.1							

RB

WG

### 馬達單體型式 / Motor Data

定格電壓 Rated volt (V)	定格扭力 Rated torque (gf-cm)	定格轉速 Rated speed (rpm)	定格電流 Rated current (mA)	無負荷轉速 No load speed (rpm)	無負荷電流 No load current (mA)	定格出力 Rated output (W)	重量 Weight (g)
3	1.5	5700	≤ 130	8000	≤ 50	0.09	3.8

PG

### 馬達單體特性 / Motor Characteristics

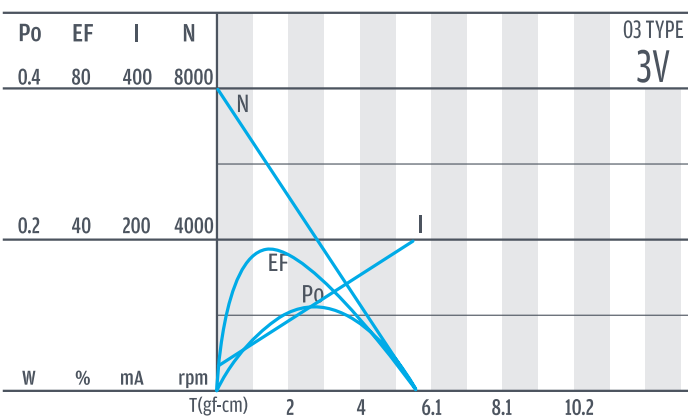

Encoder

Driver

# IG-10



## 外形尺寸 & 馬達齒啮合尺寸 / Appearance Size & Pinion Assembly Dimension

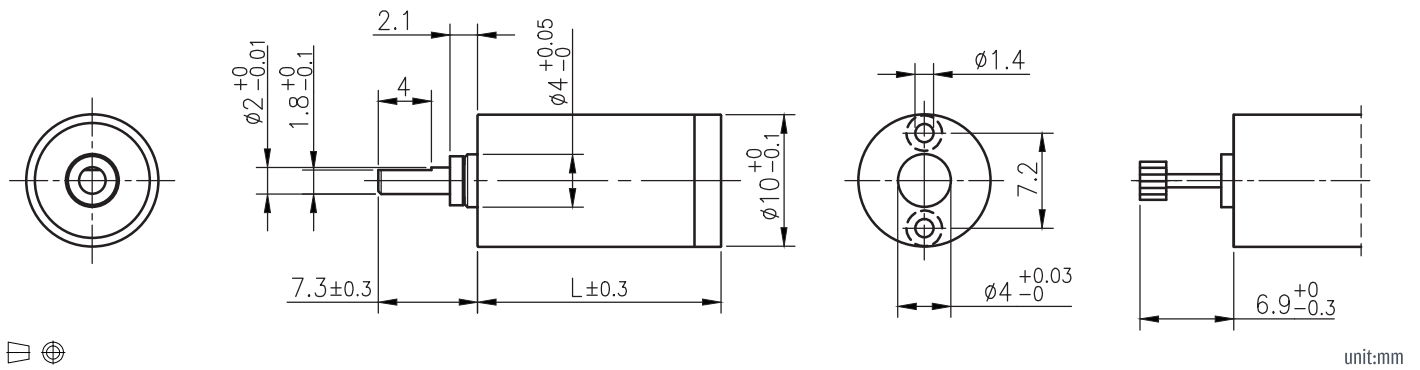

unit:mm

## 產品規格 / Product Specifications

外殼材質 Housing material	輸出軸承型式 Output shaft bearing	徑向負荷 Radial load (5mm from flange)	軸向負荷 Shaft axial load	主軸承受壓入力 Shaft press fit force	徑向間隙 Radial play of shaft	軸向間隙 Thrust play of shaft	背隙 (無負荷時) Backlash, at no-load
金屬 Metal	含油軸承 Sleeve bearing	≤ 100 gf	≤ 200 gf	≤ 500 gf	≤ 0.05 mm	≤ 0.2 mm	≤ 3°

## 馬達齒輪型式 / Pinion Specifications

模數 Module	齒數 No. of teeth	壓力角 Pressure angle	孔徑 (mm) Hole diameter	減速比 Reduction ratio
0.2	12	20°	∅ 0.99	全機種通用 Practicable

## 標準減速比型式 / Gearboxes Specifications

減速比 Reduction ratio	1/4	1/16	1/64	1/256	1/1024	1/4096									
定格容許扭力 (gf-cm max.) Rated tolerance torque	50	100	300	400	500	600									
瞬間容許扭力 (gf-cm max.) Max momentary tolerance torque	150	300	900	1200	1500	1800									
效率 Efficiency	85%	75%	65%	55%	45%	40%									
長度 Length (L)	11.7	14.8	17.9	21	24.1	27.2									
重量 (含油軸承) Weight (g) / Sleeve bearing	6.2	7.2	8.2	10.2	11.2	13.2									

- 使用相對溼度：20%~85%RH  
Operating relative humidity
- 使用溫度範圍：-10°C~+60°C  
Operating temperature range



IG

# IG-10GM

## 01 & 02 TYPE



Right Angle

### 外形尺寸 / Appearance Size

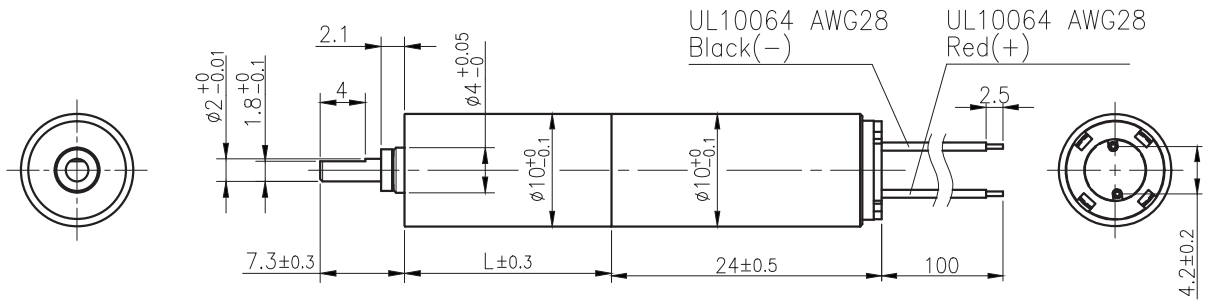

unit:mm

RA

### 齒輪箱馬達轉矩 & 速度 / Gear Motor Torque & Speed

		減速比 Reduction ratio	1/4	1/16	1/64	1/256	1/1024	1/4096				
6V	定格扭力 Rated torque (gf-cm)	10	36	124	400	500	600					
	定格轉速 Rated speed (rpm)	3000	750	187	46	11	2.9					
12V	定格扭力 Rated torque (gf-cm)	10	36	124	400	500	600					
	定格轉速 Rated speed (rpm)	3500	875	218	54	13	3.4					
軸心迴轉方向 Rotation direction		CW										
長度 Length (L)		9.7	12.8	15.9	19	22.1	25.2					

RB

WG

### 馬達單體型式 / Motor Data

定格電壓 Rated volt (V)	定格扭力 Rated torque (gf-cm)	定格轉速 Rated speed (rpm)	定格電流 Rated current (mA)	無負荷轉速 No load speed (rpm)	無負荷電流 No load current (mA)	定格出力 Rated output (W)	重量 Weight (g)
6	3	12000	≤ 140	13000	≤ 45	0.36	7.9
12	3	14000	≤ 70	15000	≤ 30	0.43	7.9

PG

### 馬達單體特性 / Motor Characteristics

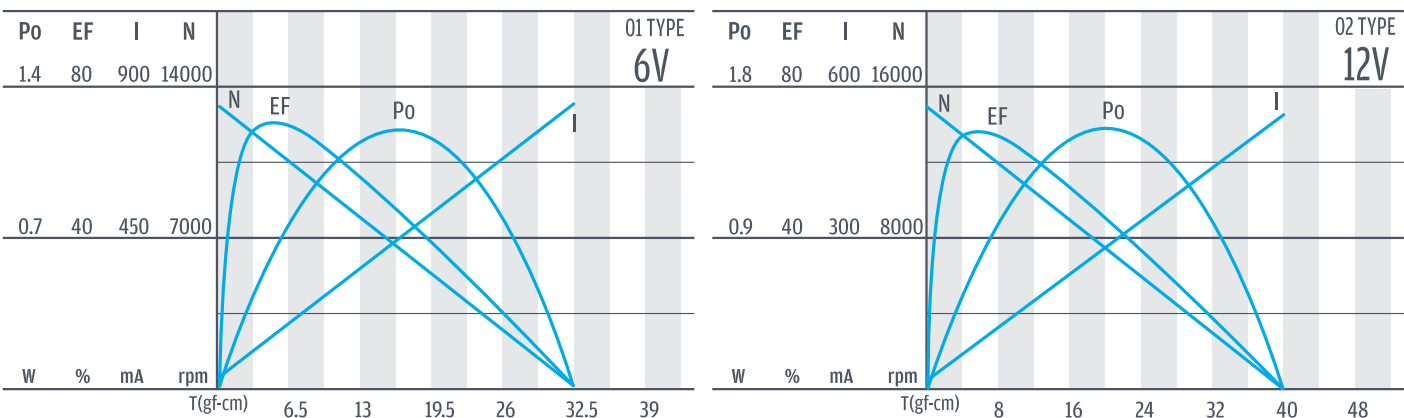

Encoder

Driver

# IG-10GM

## 03 TYPE



### 外形尺寸 / Appearance Size

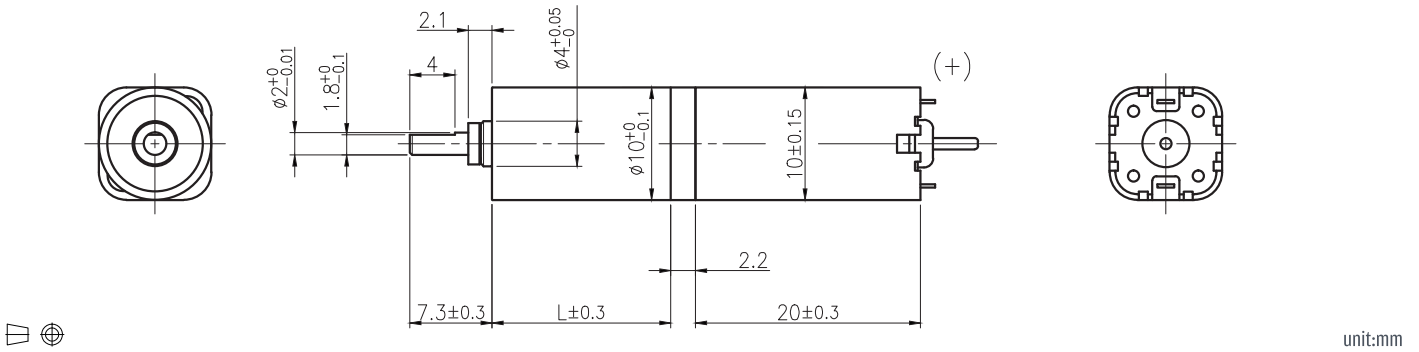

### 齒輪箱馬達轉矩 & 速度 / Gear Motor Torque & Speed

	減速比 Reduction ratio	1/4	1/16	1/64	1/256	1/1024	1/4096							
4.5V	定格扭力 Rated torque (gf-cm)	17	61	212	400	500	600							
	定格轉速 Rated speed (rpm)	1690	420	105	29	7.7	1.9							
	軸心迴轉方向 Rotation direction	CW												
	長度 Length (L)	9.7	12.8	15.9	19	22.1	25.2							

### 馬達單體型式 / Motor Data

定格電壓 Rated volt (V)	定格扭力 Rated torque (gf-cm)	定格轉速 Rated speed (rpm)	定格電流 Rated current (mA)	無負荷轉速 No load speed (rpm)	無負荷電流 No load current (mA)	定格出力 Rated output (W)	重量 Weight (g)
4.5	5.1	6800	≤ 270	8100	≤ 125	0.4	8.2

### 馬達單體特性 / Motor Characteristics

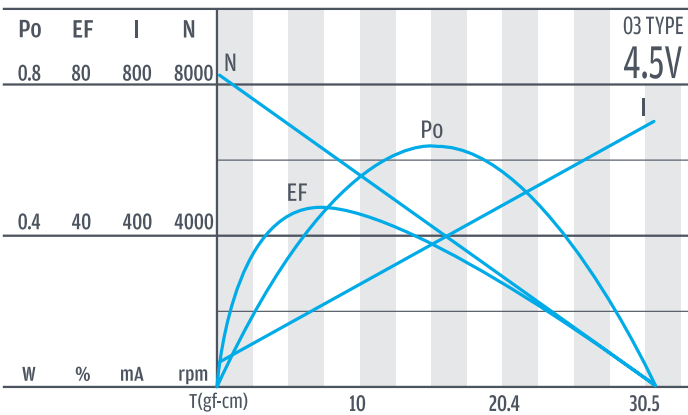

IG

# IG-12



Right Angle

## 外形尺寸 & 馬達齒鉤尺寸 / Appearance Size & Pinion Assembly Dimension

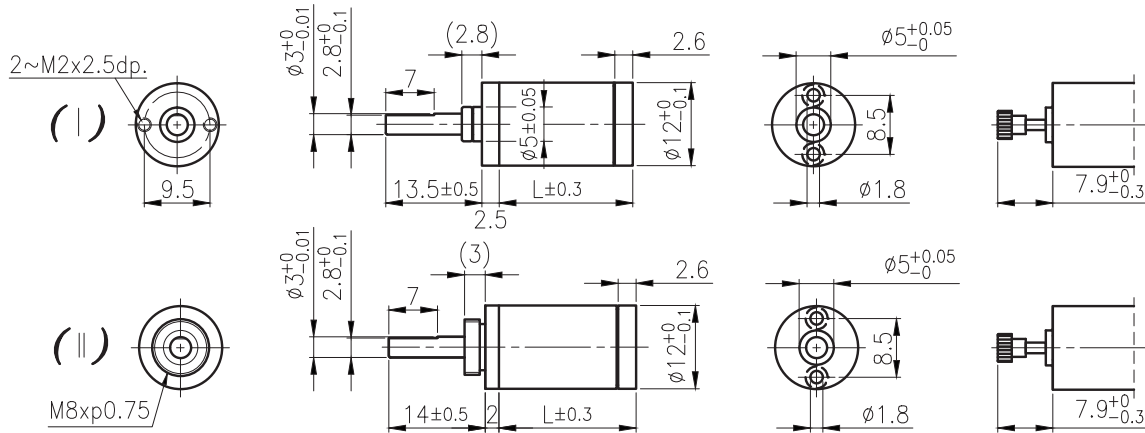

unit:mm

RA

RB

## 產品規格 / Product Specifications

外殼材質 Housing material	輸出軸承型式 Output shaft bearing	徑向負荷 Radial load (5mm from flange)	軸向負荷 Shaft axial load	主軸承受壓入力 Shaft press fit force	徑向間隙 Radial play of shaft	軸向間隙 Thrust play of shaft	背隙 (無負荷時) Backlash, at no-load
金屬 Metal	含油軸承 Sleeve bearing	≤ 0.5 kgf	≤ 0.5 kgf	≤ 1.5 kgf	≤ 0.08mm	≤ 0.2 mm	≤ 3°

WG

## 馬達齒輪型式 / Pinion Specification

模數 Module	齒數 No. of teeth	壓力角 Pressure angle	孔徑 (mm) Hole diameter	減速比 Reduction ratio
0.25	12	20°	∅ 1.49	全機種通用 Practicable

PG

## 標準減速比型式 / Gearboxes Specifications

減速比 Reduction ratio	1/4	1/16	1/64	1/256	1/1024	1/4096									
定格容許扭力 (kgf-cm max.) Rated tolerance torque	0.8	1.2	1.6	1.8	2	2									
瞬間容許扭力 (kgf-cm) Max momentary tolerance torque	2.4	3.6	4.8	5.4	6	6									
效率 Efficiency	85%	75%	65%	55%	45%	40%									
長度 Length (L)	12.8	16.1	19.4	22.7	26	29.3									
重量 (I) Weight (g)	12.1	14.2	16.3	18.4	20.5	22.6									
重量 (II) Weight (g)	12.6	14.7	16.8	18.9	21	23.1									

Encoder

Driver

- 使用相對溼度：20%~85%RH  
Operating relative humidity
- 使用溫度範圍：-10°C~+60°C  
Operating temperature range



# IG-12GM

## 01 & 02 TYPE



外形尺寸/ Appearance Size

視圖方向僅供參考 / The position of the screw hole and motor terminal in the photo is only for reference.

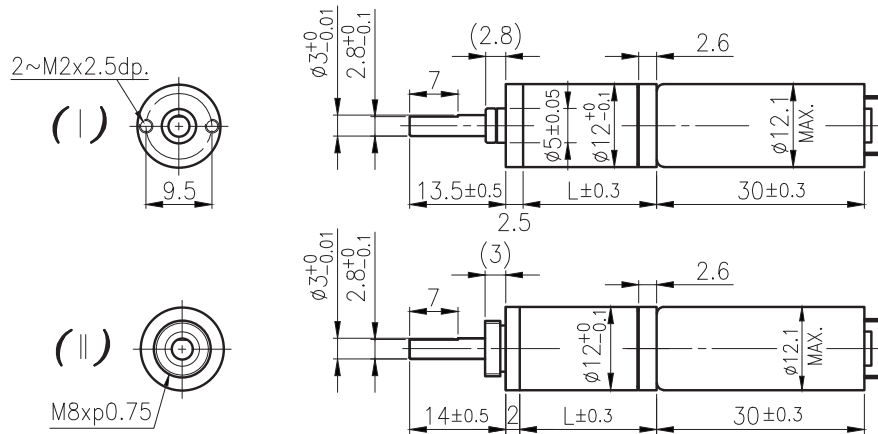

unit:mm

齒輪箱馬達轉矩 & 速度/ Gear Motor Torque & Speed

	減速比 Reduction ratio	1/4	1/16	1/64	1/256	1/1024	1/4096						
2.4V	定格扭力 Rated torque (gf-cm)	20	70	250	840	2000	2000						
	定格轉速 Rated speed (rpm)	2400	600	150	38	10	2.8						
3V	定格扭力 Rated torque (gf-cm)	19	65	230	780	2000	2000						
	定格轉速 Rated speed (rpm)	2400	610	150	39	10	2.8						
	軸心迴轉方向 Rotation direction	CW											
	長度 Length (L)	12.8	16.1	19.4	22.7	26	29.3						

馬達單體型式/ Motor Data

定格電壓 Rated volt (V)	定格扭力 Rated torque (gf-cm)	定格轉速 Rated speed (rpm)	定格電流 Rated current (mA)	無負荷轉速 No load speed (rpm)	無負荷電流 No load current (mA)	定格出力 Rated output (W)	重量 Weight (g)
2.4	6	10000	≤ 450	12500	≤ 130	0.62	13
3	5.6	10000	≤ 410	12500	≤ 120	0.59	13

馬達單體特性/ Motor Characteristics

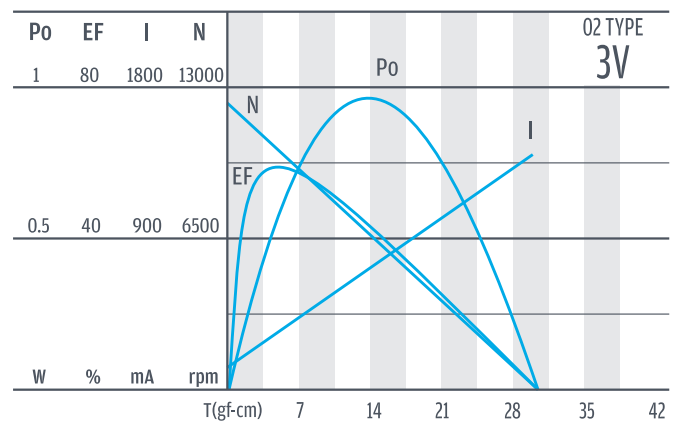
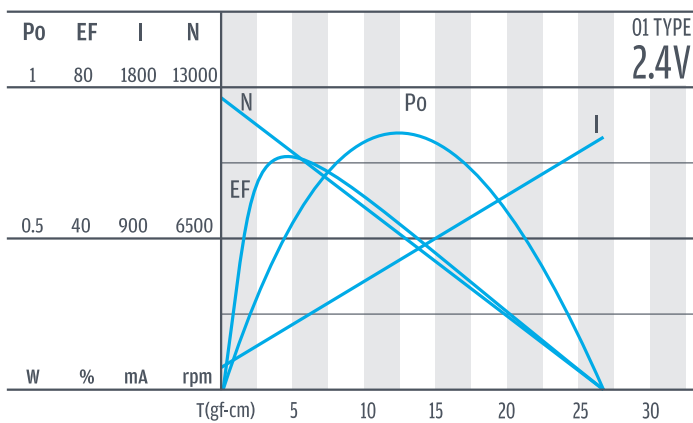

IG

# IG-13



Right Angle

## 外形尺寸 & 馬達齒銜尺寸 / Appearance Size & Pinion Assembly Dimension

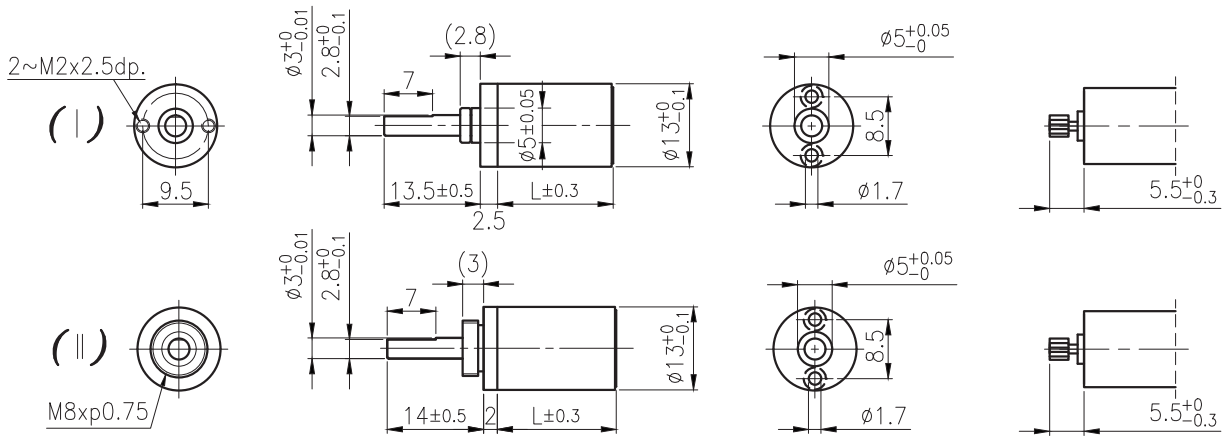

unit:mm

RA

R3

## 產品規格/ Product Specifications

外殼材質 Housing material	輸出軸承型式 Output shaft bearing	徑向負荷 Radial load (8mm from flange)	軸向負荷 Shaft axial load	主軸承受壓入力 Shaft press fit force	徑向間隙 Radial play of shaft	軸向間隙 Thrust play of shaft	背隙 (無負荷時) Backlash, at no-load
金屬 Metal	含油軸承 Sleeve bearing	≤ 0.5 kgf	≤ 0.5 kgf	≤ 1.5 kgf	≤ 0.08 mm	≤ 0.2 mm	≤ 3°

WG

## 馬達齒輪型式/ Pinion Specification

模數 Module	齒數 No. of teeth	壓力角 Pressure angle	孔徑 (mm) Hole diameter	減速比 Reduction ratio
0.25	12	20°	∅ 1.49	全機種通用 Practicable

PG

## 標準減速比型式/ Gearboxes Specifications

減速比 Reduction ratio	1/4	1/16	1/64	1/256	1/1024	1/4096									
定格容許扭力 (kgf-cm max.) Rated tolerance torque	0.8	1.2	1.6	1.8	2	2									
瞬間容許扭力 (kgf-cm) Max momentary tolerance torque	2.4	3.6	4.8	5.4	6	6									
效率 Efficiency	85%	75%	65%	55%	45%	40%									
長度 Length (L)	10.3	13.6	16.9	20.2	23.5	26.8									
重量 (I) Weight (g)	10.7	12.8	14.9	17	19.1	21.2									
重量 (II) Weight (g)	11.2	13.3	15.4	17.5	19.6	21.7									

Encoder

Driver

- 使用相對溼度：20%~85%RH  
Operating relative humidity
- 使用溫度範圍：-10°C~+60°C  
Operating temperature range

# IG-13GM

## 01 & 02 TYPE



### 外形尺寸/ Appearance Size

視圖方向僅供參考 / The position of the screw hole and motor terminal in the photo is only for reference.

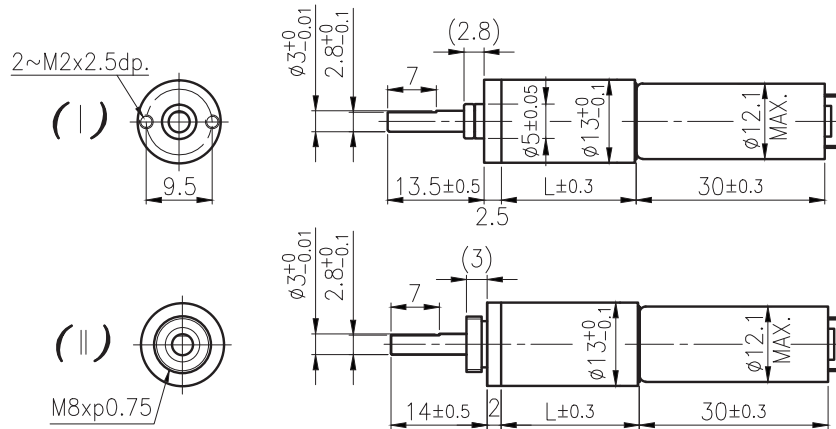

unit:mm

### 齒輪箱馬達轉矩 & 速度/ Gear Motor Torque & Speed

	減速比 Reduction ratio	1/4	1/16	1/64	1/256	1/1024	1/4096										
2.4V	定格扭力 Rated torque (gf-cm)	20	70	250	840	2000	2000										
	定格轉速 Rated speed (rpm)	2400	600	150	38	10	2.8										
3V	定格扭力 Rated torque (gf-cm)	19	65	230	780	2000	2000										
	定格轉速 Rated speed (rpm)	2400	610	150	39	10	2.8										
	軸心迴轉方向 Rotation direction	CW															
	長度 Length (L)	10.3	13.6	16.9	20.2	23.5	26.8										

### 馬達單體型式/ Motor Data

定格電壓 Rated volt (V)	定格扭力 Rated torque (gf-cm)	定格轉速 Rated speed (rpm)	定格電流 Rated current (mA)	無負荷轉速 No load speed (rpm)	無負荷電流 No load current (mA)	定格出力 Rated output (W)	重量 Weight (g)
2.4	6	10000	≤ 450	12500	≤ 130	0.62	13
3	5.6	10000	≤ 410	12500	≤ 120	0.59	13

### 馬達單體特性/ Motor Characteristics

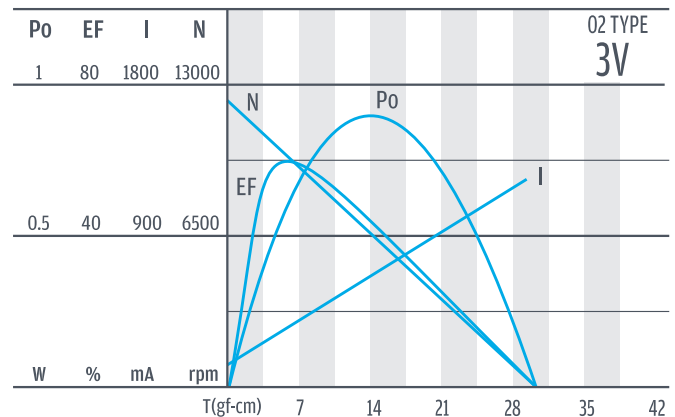
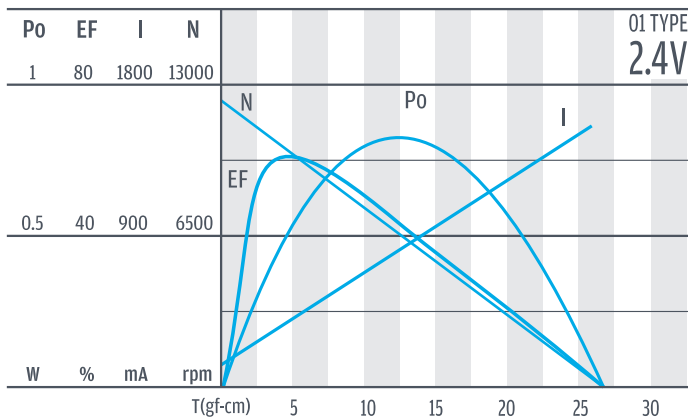



IG

# IG-16

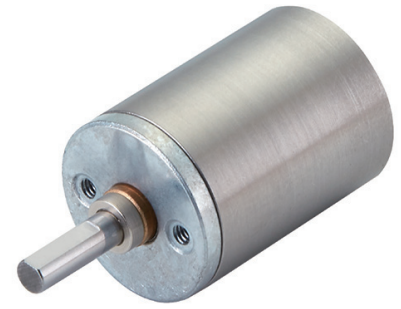

Right Angle

## 外形尺寸&馬達齒鉚合尺寸 / Appearance Size & Pinion Assembly Dimension

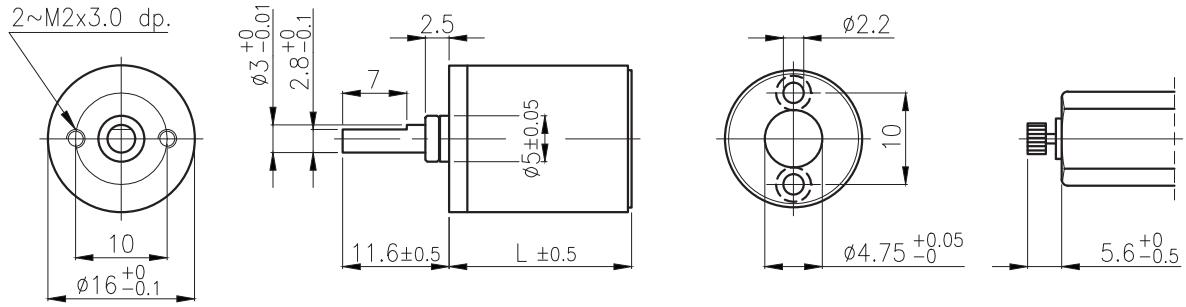

unit:mm

RA

RB

## 產品規格/ Product Specifications

外殼材質 Housing material	輸出軸承型式 Output shaft bearing	徑向負荷 Radial load (10mm from flange)	軸向負荷 Shaft axial load	主軸承受壓力 Shaft press fit force	徑向間隙 Radial play of shaft	軸向間隙 Thrust play of shaft	背隙 (無負荷時) Backlash, at no-load
金屬 Metal	含油軸承 Sleeve bearing	≤ 0.5 kgf	≤ 0.5 kgf	≤ 1.5 kgf	≤ 0.08 mm	≤ 0.2 mm	≤ 3°

WG

## 馬達齒輪型式/ Pinion Specification

模數 Module	齒數 No. of teeth	壓力角 Pressure angle	孔徑 (mm) Hole diameter	減速比 Reduction ratio
0.3	10	20°	∅ 1.49	1/29, 1/104, 1/128, 1/157, 1/455, 1/561, 1/690, 1/1996, 1/3027
0.3	13	20°	∅ 1.49, ∅ 1.98	1/4, 1/16, 1/19, 1/62, 1/72, 1/84, 1/231, 1/316, 1/370, 1/1014, 1/1621
0.3	16	20°	∅ 1.49, ∅ 1.98	1/14, 1/53

PG

## 標準減速比型式/ Gearboxes Specifications

減速比 Reduction ratio	1/4	1/14	1/16	1/19	1/29	1/53	1/62	1/72	1/84	1/104	1/128	1/157	1/231	1/316	1/370	1/455	1/561	1/690	1/1014	1/1621	1/1996	1/3027
定格容許扭力 (kgf-cm max.) Rated tolerance torque	0.8	1.2	1.2	1.2	1.2	1.6	1.6	1.6	1.6	1.6	1.6	1.6	2	2	2	2	2	2	2.4	2.4	2.4	2.4
瞬間容許扭力 (kgf-cm) Max momentary tolerance torque	2.4	3.6	3.6	3.6	3.6	4.8	4.8	4.8	4.8	4.8	4.8	4.8	6	6	6	6	6	6	7.2	7.2	7.2	7.2
效率 Efficiency	80%	70%	70%	70%	70%	60%	60%	60%	60%	60%	60%	60%	50%	50%	50%	50%	50%	50%	40%	40%	40%	40%
長度 Length (L)	15.05	18.70	18.70	18.70	18.70	22.35	22.35	22.35	22.35	22.35	22.35	22.35	26	26	26	26	26	26	29.65	29.65	29.65	29.65
重量 (含油軸承) Weight (g) /Sleeve bearing	19	23	23	23	23	27	27	27	27	27	27	27	31	31	31	31	31	31	35	35	35	35

Encoder

Driver

- 使用相對溼度：20%~85%RH  
Operating relative humidity
- 使用溫度範圍：-10°C~+60°C  
Operating temperature range

# IG-16GM

## 04 & 05 TYPE



### 外形尺寸/ Appearance Size

視圖方向僅供參考 / The position of the screw hole and motor terminal in the photo is only for reference.

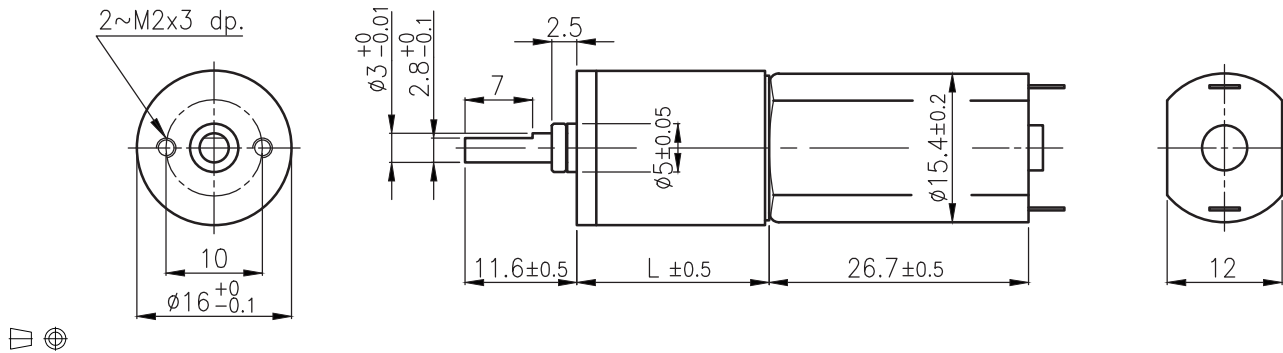

unit:mm

### 齒輪箱馬達轉矩 & 速度/ Gear Motor Torque & Speed

減速比 Reduction ratio		1/4	1/14	1/16	1/19	1/29	1/53	1/62	1/72	1/84	1/104	1/128	1/157	1/231	1/316	1/370	1/455	1/561	1/690	1/1014	1/1621	1/1996	1/3027
12V	定格扭力 Rated torque (gf-cm)	21	60	70	82	120	193	220	260	300	380	460	550	700	950	1100	1350	1700	2000	2400	2400	2400	2400
	定格轉速 Rated speed (rpm)	1330	430	377	315	205	117	100	85	73	59	48	39	26	19	16	13.5	11	8.9	6	3.8	3.2	2.3
24V	定格扭力 Rated torque (gf-cm)	31	85	103	120	180	284	330	380	450	560	690	850	1000	1400	1600	2000	2000	2000	2400	2400	2400	2400
	定格轉速 Rated speed (rpm)	2400	760	669	555	365	208	170	150	130	105	85	69	47	34	29	24	19.5	15.9	11	7.2	6.1	4.1
軸心迴轉方向 Rotation direction		CW																					
長度 Length (L)		15.05	18.70			22.35					26					29.65							

### 馬達單體型式/ Motor Data

定格電壓 Rated volt (V)	定格扭力 Rated torque (gf-cm)	定格轉速 Rated speed (rpm)	定格電流 Rated current (mA)	無負荷轉速 No load speed (rpm)	無負荷電流 No load current (mA)	定格出力 Rated output (W)	重量 Weight (g)
12	6.1	6200	≤ 85	8000	≤ 50	0.394	18
24	9	11000	≤ 90	13500	≤ 50	1.026	18

### 馬達單體特性/ Motor Characteristics

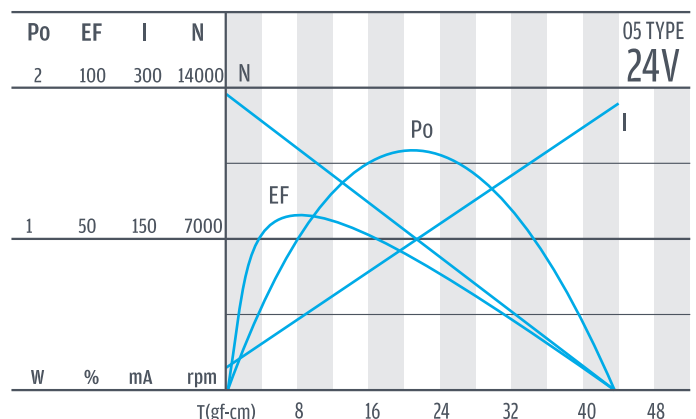
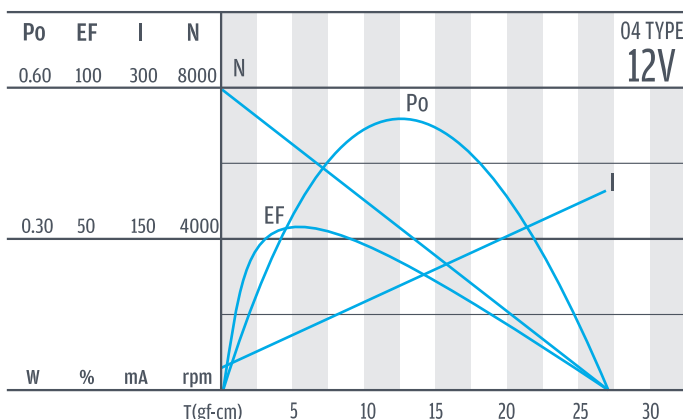

IG

# IG-16GM

## 07 TYPE



Right Angle

### 外形尺寸/ Appearance Size

視圖方向僅供參考 / The position of the screw hole and motor terminal in the photo is only for reference.

RA

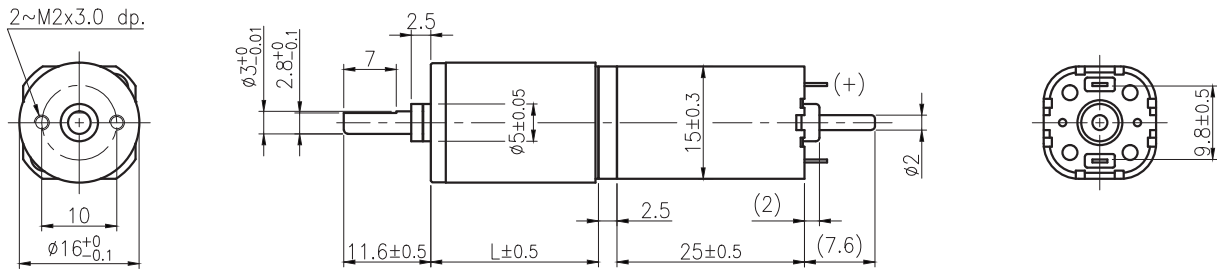

unit:mm

RB

### 齒輪箱馬達轉矩 & 速度/ Gear Motor Torque & Speed

減速比 Reduction ratio	1/4	1/14	1/16	1/19	1/53	1/62	1/72	1/84	1/231	1/316	1/370	1/1014	1/1621
24V 定格扭力 Rated torque (gf-cm)	140	400	465	545	1320	1505	1600	1600	2000	2000	2000	2400	2400
24V 定格轉速 Rated speed (rpm)	1410	440	375	320	110	100	89	79	32	24	20.8	7.8	4.9
軸心迴轉方向 Rotation direction	CW												
長度 Length (L)	15.05	18.70				22.35				26		29.65	

WG

### 馬達單體型式/ Motor Data

定格電壓 Rated volt (V)	定格扭力 Rated torque (gf-cm)	定格轉速 Rated speed (rpm)	定格電流 Rated current (mA)	無負荷轉速 No load speed (rpm)	無負荷電流 No load current (mA)	定格出力 Rated output (W)	重量 Weight (g)
24	40.8	6200	≤ 260	8050	≤ 85	2.6	21

PG

### 馬達單體特性/ Motor Characteristics

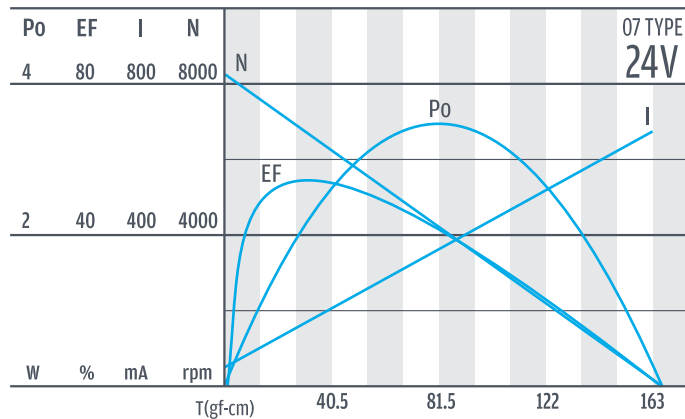

Encoder

Driver

# IG-16GM

## 11 & 12 TYPE



### 外形尺寸/ Appearance Size

視圖方向僅供參考 / The position of the screw hole and motor terminal in the photo is only for reference.

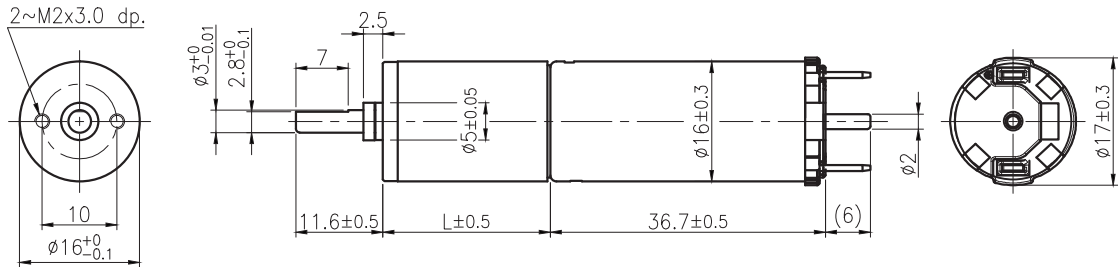

unit:mm

### 齒輪箱馬達轉矩 & 速度/ Gear Motor Torque & Speed

減速比 Reduction ratio		1/4	1/14	1/16	1/19	1/53	1/62	1/72	1/84	1/231	1/316	1/370	1/1014	1/1621
12V	定格扭力 Rated torque (gf-cm)	140	390	460	535	1295	1475	1600	1600	2000	2000	2000	2400	2400
	定格轉速 Rated speed (rpm)	1310	410	350	300	105	93	82	74	30	23	20	7.5	4.8
24V	定格扭力 Rated torque (gf-cm)	140	390	460	535	1295	1475	1600	1600	2000	2000	2000	2400	2400
	定格轉速 Rated speed (rpm)	1380	430	365	315	112	98	86	78	32	24	21	8	5
軸心迴轉方向 Rotation direction		CCW												
長度 Length (L)		15.05	18.70				22.35			26			29.65	

### 馬達單體型式/ Motor Data

定格電壓 Rated volt (V)	定格扭力 Rated torque (gf-cm)	定格轉速 Rated speed (rpm)	定格電流 Rated current (mA)	無負荷轉速 No load speed (rpm)	無負荷電流 No load current (mA)	定格出力 Rated output (W)	重量 Weight (g)
12	40	5780	≤ 480	8100	≤ 160	2.4	32
24	40	6070	≤ 250	8500	≤ 90	2.5	32

### 馬達單體特性/ Motor Characteristics

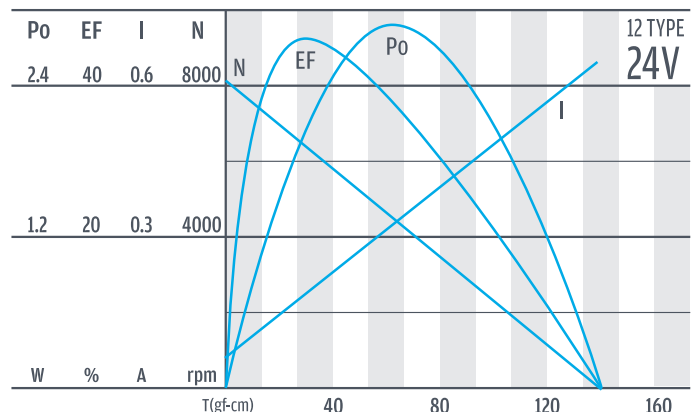
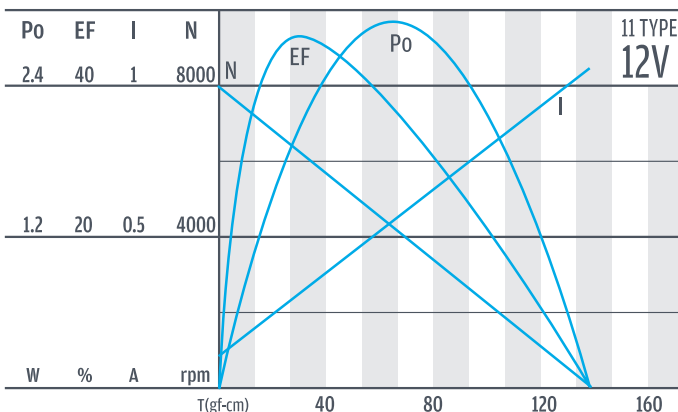

IG

# IG-16GM

## 61 & 62 TYPE

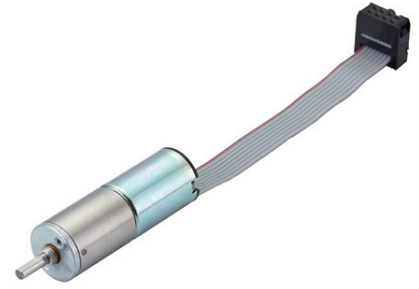

Right Angle

### 外形尺寸 / Appearance Size

視圖方向僅供參考 / The position of the screw hole and motor terminal in the photo is only for reference.

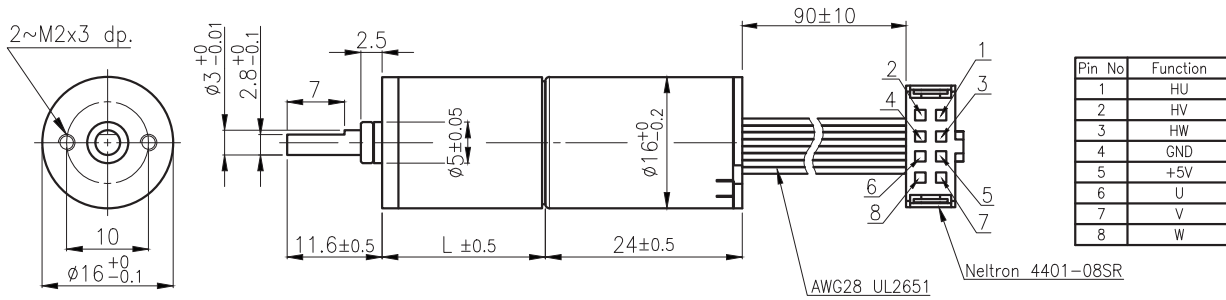

unit:mm

RA

RB

### 齒輪箱馬達轉矩 & 速度 / Gear Motor Torque & Speed

減速比 Reduction ratio	1/4	1/14	1/16	1/19	1/29	1/53	1/62	1/72	1/84	1/104	1/128	1/157	1/231	1/316	1/370	1/455	1/561	1/690	1/1014	1/1621	1/1996	1/3027
<b>8.5V</b> 定格扭力 Rated torque (gf-cm)	84	236	276	322	489	777	887	1038	1213	1494	1600	1600	2000	2000	2000	2000	2000	2000	2400	2400	2400	2400
定格轉速 Rated speed (rpm)	2280	710	605	520	340	185	160	135	115	95	84	70	45	35	30	25	20	17	12	7.5	6.4	4.2
<b>24V</b> 定格扭力 Rated torque (gf-cm)	140	393	460	538	816	1295	1479	1600	1600	1600	1600	1600	2000	2000	2000	2000	2000	2000	2400	2400	2400	2400
定格轉速 Rated speed (rpm)	2280	710	605	520	340	185	160	145	125	105	90	74	50	38	33	27	22	18	12	8	6	4
軸心迴轉方向 Rotation direction	CW/CCW																					
長度 Length (L)	15.05	18.70		22.35				26				29.65										

WG

PG

### 馬達單體型式 / Motor Data

定格電壓 Rated volt (V)	定格扭力 Rated torque (gf-cm)	定格轉速 Rated speed (rpm)	定格電流 Rated current (mA)	無負荷轉速 No load speed (rpm)	無負荷電流 No load current (mA)	定格出力 Rated output (W)	重量 Weight (g)
8.5	24	10000	≤700	13300	≤230	2.46	20
24	40	10000	≤370	13300	≤170	4.1	20

### 馬達單體特性 / Motor Characteristics

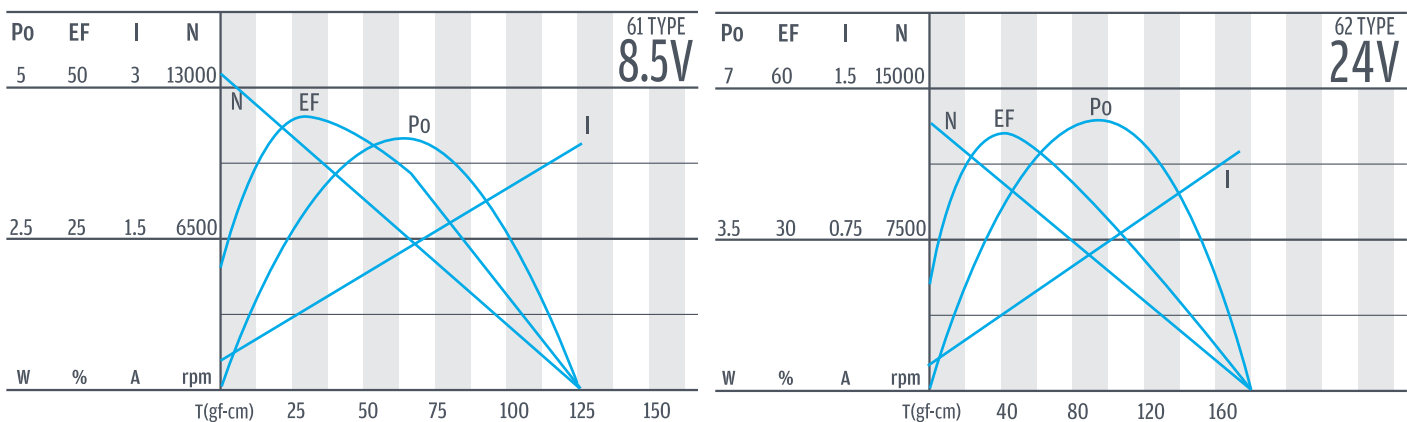

Encoder

Driver

# IG-22



## 外形尺寸 & 馬達齒鉤合尺寸 / Appearance Size & Pinion Assembly Dimension

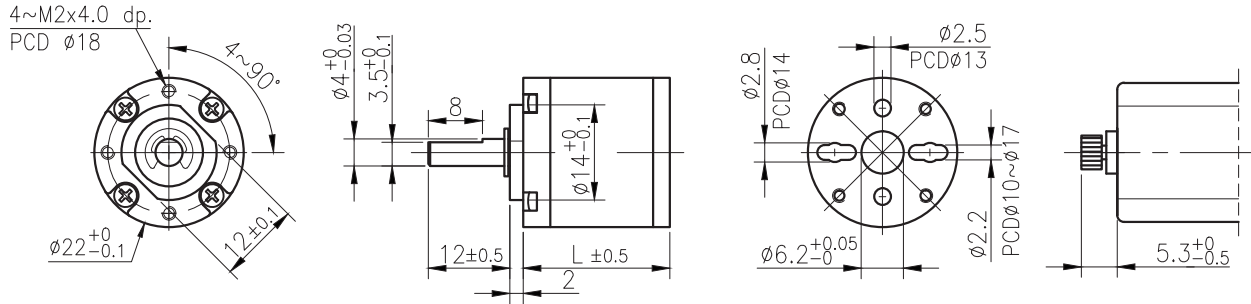

unit:mm

## 產品規格/ Product Specifications

外殼材質 Housing material	輸出軸承型式 Output shaft bearing	徑向負荷 Radial load (10mm from flange)	軸向負荷 Shaft axial load	主軸承受壓入力 Shaft press fit force	徑向間隙 Radial play of shaft	軸向間隙 Thrust play of shaft	背隙(無負荷時) Backlash, at no-load
金屬 Metal	含油軸承 Sleeve bearing	$\leq 0.8$ kgf	$\leq 0.6$ kgf	$\leq 5$ kgf	$\leq 0.08$ mm	$\leq 0.2$ mm	$\leq 3^\circ$
金屬 Metal	滾珠軸承 Ball bearings	$\leq 1$ kgf	$\leq 0.6$ kgf	$\leq 5$ kgf	$\leq 0.05$ mm	$\leq 0.2$ mm	$\leq 3^\circ$

## 馬達齒輪型式/ Pinion Specifications

模數 Module	齒數 No. of teeth	壓力角 Pressure angle	孔徑 (mm) Hole diameter	減速比 Reduction ratio
0.3	13	$20^\circ$	$\phi 1.98$	1/4, 1/16, 1/19, 1/62, 1/72, 1/84, 1/104, 1/231, 1/270 1/316, 1/370, 1/455, 1/1014, 1/1249, 1/1621, 1/1996
0.3	16	$20^\circ$	$\phi 1.98$	1/14, 1/53, 1/198, 1/742

## 標準減速比型式/ Gearboxes Specifications

減速比 Reduction ratio	1/4	1/14	1/16	1/19	1/53	1/62	1/72	1/84	1/104	1/198	1/231	1/270	1/316	1/370	1/455	1/742	1/1014	1/1249	1/1621	1/1996
定格容許扭力 (kgf-cm max.) Rated tolerance torque	1	1.5	1.5	1.5	2	2	2	2	2	2.5	2.5	2.5	2.5	2.5	2.5	3	3	3	3	3
瞬間容許扭力 (kgf-cm) Max momentary tolerance torque	3	4.5	4.5	4.5	6	6	6	6	6	7.5	7.5	7.5	7.5	7.5	7.5	9	9	9	9	9
效率 Efficiency	80%	70%	70%	70%	60%	60%	60%	60%	60%	50%	50%	50%	50%	50%	50%	40%	40%	40%	40%	40%
長度 Length (L)	14.40	18.05	18.05	18.05	21.70	21.70	21.70	21.70	21.70	25.35	25.35	25.35	25.35	25.35	25.35	29	29	29	29	29
重量 (含油軸承) Weight (g) / Sleeve bearing	27	31	31	31	35	35	35	35	50	60	60	60	60	60	60	65	65	65	65	65
重量 (滾珠軸承) Weight (g) / Ball bearings	26	30	30	30	34	34	34	34	49	59	59	59	59	59	59	64	64	64	64	64

- 使用相對溼度：20%~85%RH  
Operating relative humidity
- 使用溫度範圍：-10°C~+60°C  
Operating temperature range



IG

# IG-22GM

## 01 & 02 TYPE



Right Angle

### 外形尺寸/ Appearance Size

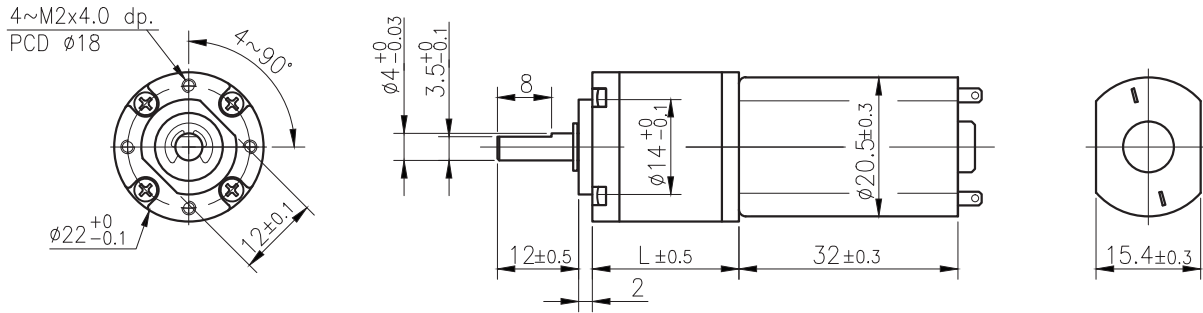

unit:mm

RA

### 齒輪箱馬達轉矩 & 速度/ Gear Motor Torque & Speed

減速比 Reduction ratio	1/4	1/14	1/16	1/19	1/53	1/62	1/72	1/84	1/104	1/198	1/231	1/270	1/316	1/370	1/455	1/742	1/1014	1/1249	1/1621	1/1996
12V 定格扭力 Rated torque (gf-cm)	77	215	250	295	695	810	950	1100	1370	2100	2500	2500	2500	2500	2500	3000	3000	3000	3000	3000
12V 定格轉速 Rated speed (rpm)	1450	470	405	348	127	109	93	79	64	34	29	25	22	19	15.5	9.5	7.4	6	4.6	3.8
24V 定格扭力 Rated torque (gf-cm)	77	215	250	295	695	810	950	1100	1370	2100	2500	2500	2500	2500	2500	3000	3000	3000	3000	3000
24V 定格轉速 Rated speed (rpm)	1600	515	450	384	140	120	103	88	71	37	32	28	23.5	21	17.5	10.5	8	6.6	5	4.2
軸心迴轉方向 Rotation direction	CCW																			
長度 Length (L)	14.40	18.05					21.70					25.35						29		

RB

WG

### 馬達單體型式/ Motor Data

定格電壓 Rated volt (V)	定格扭力 Rated torque (gf-cm)	定格轉速 Rated speed (rpm)	定格電流 Rated current (mA)	無負荷轉速 No load speed (rpm)	無負荷電流 No load current (mA)	定格出力 Rated output (W)	重量 Weight (g)
12	22	6700	≤ 200	8000	≤ 70	1.5	32
24	22	7400	≤ 110	9000	≤ 40	1.7	32

PG

### 馬達單體特性/ Motor Characteristics

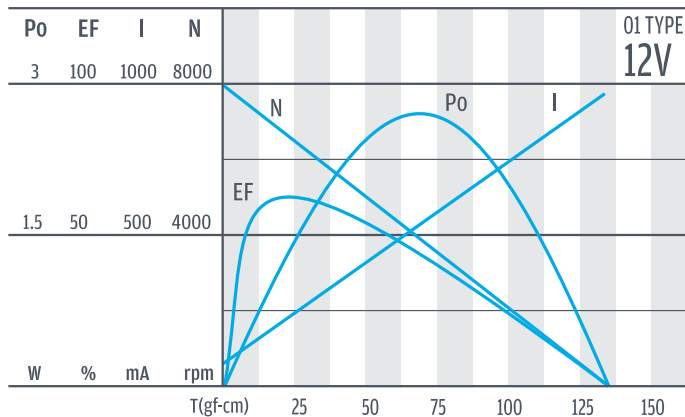

Encoder

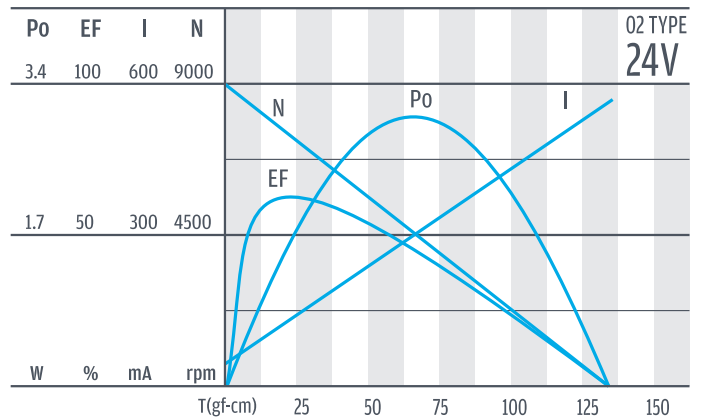

Driver

# IG-22GM

## 03 & 04 TYPE



### 外形尺寸/ Appearance Size

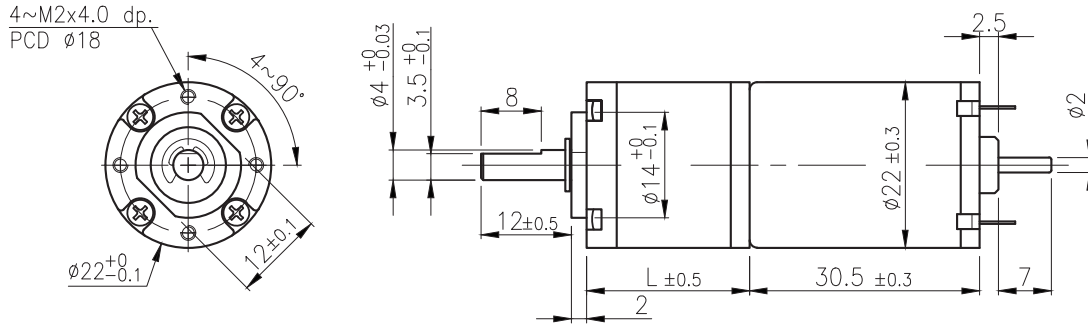

unit:mm

### 齒輪箱馬達轉矩 & 速度/ Gear Motor Torque & Speed

減速比 Reduction ratio		1/4	1/14	1/16	1/19	1/53	1/62	1/72	1/84	1/104	1/198	1/231	1/270	1/316	1/370	1/455	1/742	1/1014	1/1249	1/1621	1/1996
12V	定格扭力 Rated torque (gf-cm)	100	300	350	410	970	1100	1300	1500	1900	2500	2500	2500	2500	2500	2500	3000	3000	3000	3000	3000
	定格轉速 Rated speed (rpm)	1000	340	290	245	90	77	66	56	46	24	21	18	16	13.5	11	7.3	5	4.2	3.3	2.7
24V	定格扭力 Rated torque (gf-cm)	120	360	420	490	1150	1300	1500	1800	2000	2500	2500	2500	2500	2500	2500	3000	3000	3000	3000	3000
	定格轉速 Rated speed (rpm)	1000	330	280	240	89	76	65	55	46	24	21	18	16	13.5	11	7.3	5	4.2	3.3	2.7
軸心迴轉方向 Rotation direction		CW																			
長度 Length (L)		14.40	18.05			21.70			25.35			29									

### 馬達單體型式/ Motor Data

定格電壓 Rated volt (V)	定格扭力 Rated torque (gf-cm)	定格轉速 Rated speed (rpm)	定格電流 Rated current (mA)	無負荷轉速 No load speed (rpm)	無負荷電流 No load current (mA)	定格出力 Rated output (W)	重量 Weight (g)
12	31	4790	≤ 240	6000	≤ 80	1.52	43
24	37	4710	≤ 145	6000	≤ 55	1.79	43

### 馬達單體特性/ Motor Characteristics

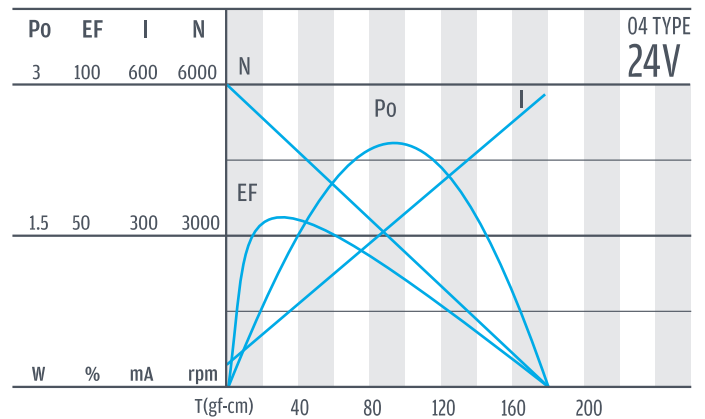
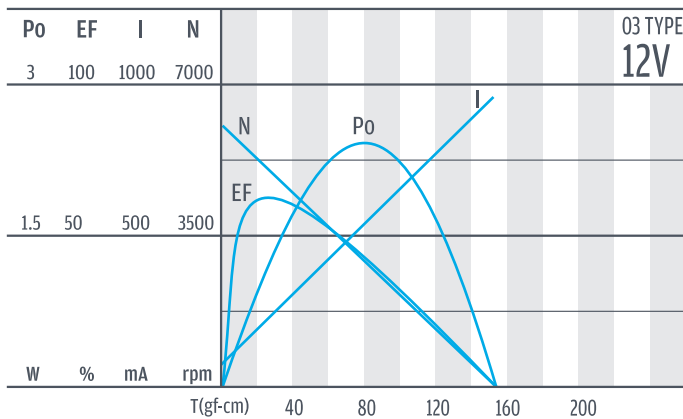

IG

# IG-22GM

## 08 TYPE

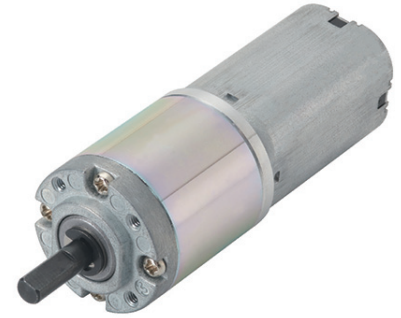

Right Angle

### 外形尺寸/ Appearance Size

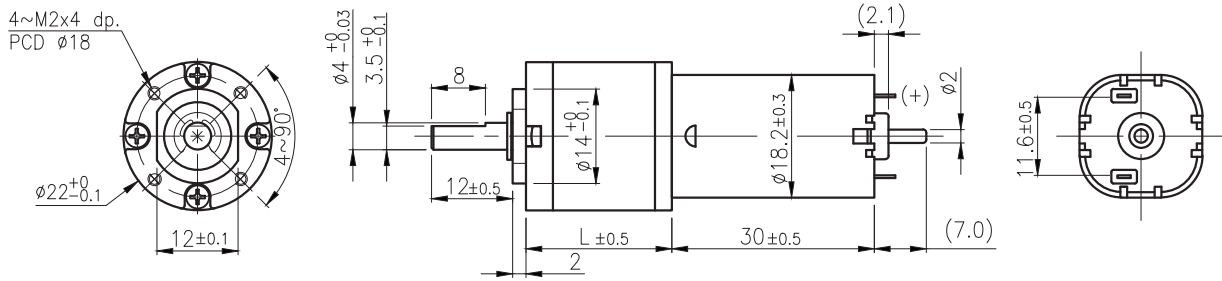

unit:mm

RA

### 齒輪箱馬達轉矩 & 速度/ Gear Motor Torque & Speed

減速比 Reduction ratio	1/4	1/14	1/16	1/19	1/53	1/62	1/72	1/84	1/104	1/198	1/231	1/270	1/316	1/370	1/455	1/742	1/1014	1/1249	1/1621	1/1996
24V 定格扭力 Rated torque (gf-cm)	355	1000	1170	1370	2000	2000	2000	2000	2000	2500	2500	2500	2500	2500	2500	3000	3000	3000	3000	3000
24V 定格轉速 Rated speed (rpm)	1330	410	350	300	120	100	90	80	65	35	30	25	22	19	15	9.8	7.2	5.9	4.5	3.7
軸心迴轉方向 Rotation direction	CW																			
長度 Length (L)	14.40	18.05					21.70						25.35					29		

RB

WG

### 馬達單體型式/ Motor Data

定格電壓 Rated volt (V)	定格扭力 Rated torque (gf-cm)	定格轉速 Rated speed (rpm)	定格電流 Rated current (mA)	無負荷轉速 No load speed (rpm)	無負荷電流 No load current (mA)	定格出力 Rated output (W)	重量 Weight (g)
24	102	5840	≤ 640	7810	≤ 140	6.35	36

PG

### 馬達單體特性/ Motor Characteristics

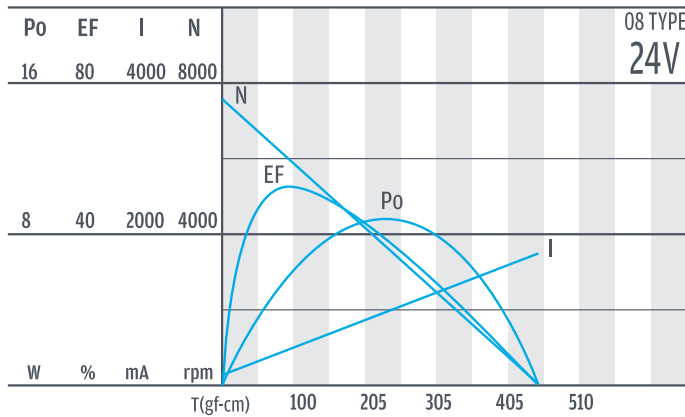

Encoder

Driver

# IG-22C



## 外形尺寸 & 馬達齒鉤合尺寸 / Appearance Size & Pinion Assembly Dimension

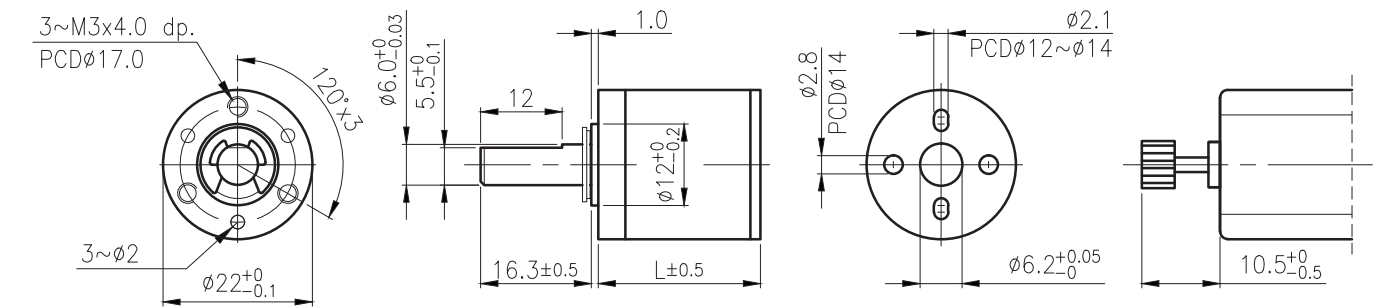

unit:mm

## 產品規格/ Product Specifications

外殼材質 Housing material	輸出軸承型式 Output shaft bearing	徑向負荷 Radial load (10mm from flange)	軸向負荷 Shaft axial load	主軸承受壓入力 Shaft press fit force	徑向間隙 Radial play of shaft	軸向間隙 Thrust play of shaft	背隙(無負荷時) Backlash, at no-load
金屬 Metal	含油軸承 Sleeve bearings	$\leq 1$ kgf	$\leq 0.7$ kgf	$\leq 6$ kgf	$\leq 0.08$ mm	$\leq 0.3$ mm	$\leq 2.5^\circ$
金屬 Metal	滾珠軸承 Ball bearings	$\leq 1.2$ kgf	$\leq 0.7$ kgf	$\leq 6$ kgf	$\leq 0.05$ mm	$\leq 0.3$ mm	$\leq 2.5^\circ$

## 馬達齒輪型式/ Pinion Specifications

模數 Module	齒數 No. of teeth	壓力角 Pressure angle	孔徑 (mm) Hole diameter	減速比 Reduction ratio
0.4	10	20°	$\phi$ 1.98, $\phi$ 2.28	1/25, 1/110, 1/136, 1/484, 1/597, 1/735, 1/2124, 1/3968
0.4	13	20°	$\phi$ 1.98, $\phi$ 2.28	1/20, 1/77, 1/90, 1/336, 1/393, 1/1079, 1/1475
0.4	16	20°	$\phi$ 1.98, $\phi$ 2.28	1/18, 1/66, 1/246
0.4	12	20°	$\phi$ 1.98, $\phi$ 2.28	1/5

## 標準減速比型式/ Gearboxes Specifications

減速比 Reduction ratio	1/5	1/18	1/20	1/25	1/66	1/77	1/90	1/110	1/136	1/246	1/336	1/393	1/484	1/597	1/735	1/1079	1/1475	1/2124	1/3968
定格容許扭力 (kgf-cm max.) Rated tolerance torque	1	3	3	3	4	4	4	4	4	5	5	5	5	5	5	6	6	6	6
瞬間容許扭力 (kgf-cm) Max momentary tolerance torque	3	9	9	9	12	12	12	12	12	15	15	15	15	15	15	18	18	18	18
效率 Efficiency	80%	70%	70%	70%	60%	60%	60%	60%	60%	50%	50%	50%	50%	50%	50%	40%	40%	40%	40%
長度 Length (L)	23.3	29.5	29.5	29.5	35.7	35.7	35.7	35.7	35.7	41.9	41.9	41.9	41.9	41.9	41.9	48.1	48.1	48.1	48.1
重量 (含油軸承) Weight (g) / Sleeve bearings	46	51	51	51	58	58	58	58	58	65	65	65	65	65	65	72	72	72	72
重量 (滾珠軸承) Weight (g) / Ball bearings	46	51	51	51	58	58	58	58	58	65	65	65	65	65	65	72	72	72	72

- 使用相對溼度：20%~85%RH  
Operating relative humidity
- 使用溫度範圍：-10°C~+60°C  
Operating temperature range

IG

# IG-22CGM

## 01 & 02 TYPE



Right Angle

### 外形尺寸/ Appearance Size

視圖方向僅供參考 / The position of the screw hole and motor terminal in the photo is only for reference.

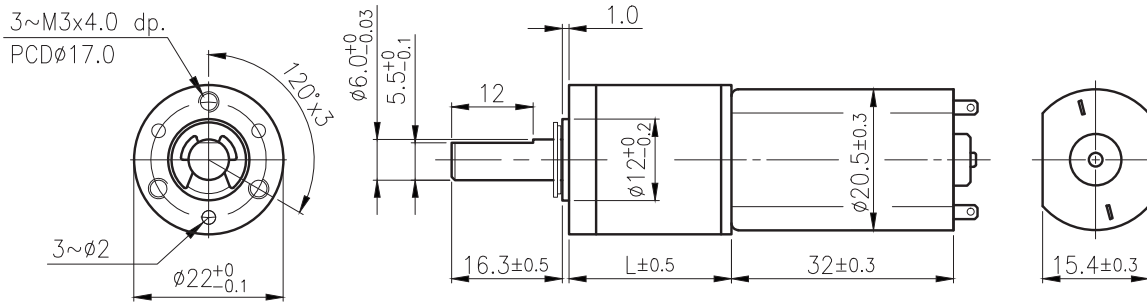

unit:mm

RA

### 齒輪箱馬達轉矩 & 速度/ Gear Motor Torque & Speed

減速比 Reduction ratio	1/5	1/18	1/20	1/25	1/66	1/77	1/90	1/110	1/136	1/246	1/336	1/393	1/484	1/597	1/735	1/1079	1/1475	1/2124	1/3968		
12V 定格扭力 Rated torque (gf-cm)	80	270	310	380	850	1000	1150	1400	1700	2600	3700	4200	5000	5000	5000	6000	6000	6000	6000		
12V 定格轉速 Rated speed (rpm)	1400	375	325	260	101	86	74	60	48	26	19	16	13.8	11.5	9.5	6.7	5	3.4	1.8		
24V 定格扭力 Rated torque (gf-cm)	80	270	310	380	850	1000	1150	1400	1700	2600	3700	4200	5000	5000	5000	6000	6000	6000	6000		
24V 定格轉速 Rated speed (rpm)	1550	414	355	290	110	95	82	66	53	29	21	18	15.3	12.7	10.5	7.4	5.5	3.9	1.95		
軸心迴轉方向 Rotation direction	CCW																				
長度 Length (L)	23.3		29.5		35.7				41.9				48.1								

RB

WG

### 馬達單體型式/ Motor Data

定格電壓 Rated volt (V)	定格扭力 Rated torque (gf-cm)	定格轉速 Rated speed (rpm)	定格電流 Rated current (mA)	無負荷轉速 No load speed (rpm)	無負荷電流 No load current (mA)	定格出力 Rated output (W)	重量 Weight (g)
12	22	6700	≤ 200	8000	≤ 70	1.5	32
24	22	7400	≤ 110	9000	≤ 40	1.7	32

PG

### 馬達單體特性/ Motor Characteristics

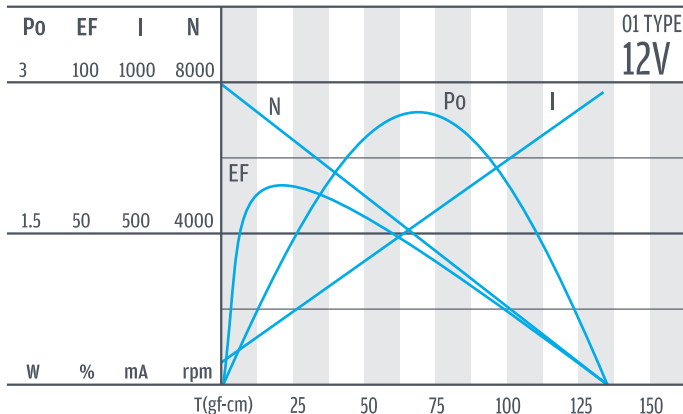

Encoder

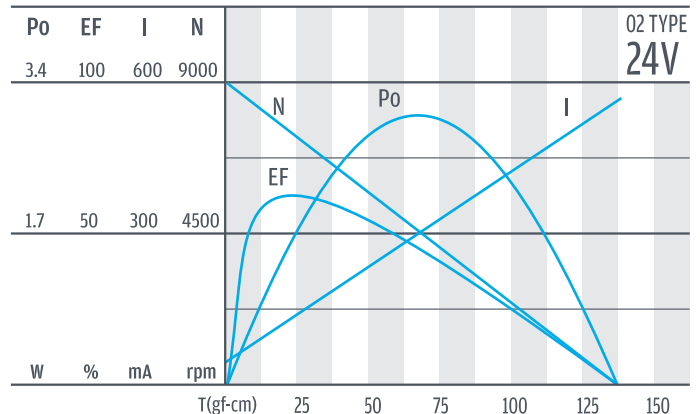

Driver

# IG-22CGM

## 03 & 04 TYPE



### 外形尺寸/ Appearance Size

視圖方向僅供參考 / The position of the screw hole and motor terminal in the photo is only for reference.

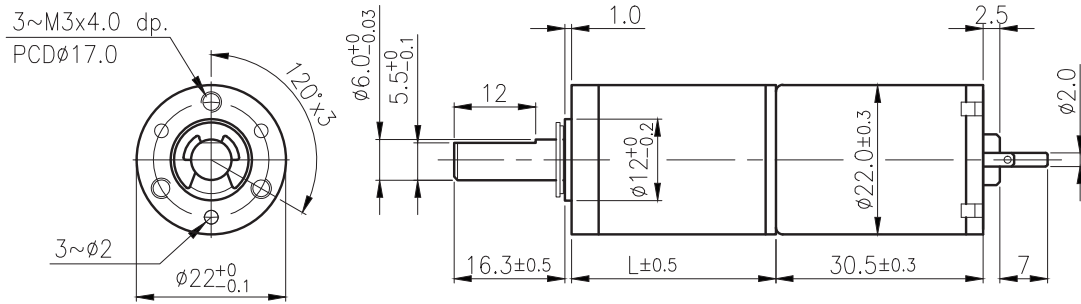

unit:mm

### 齒輪箱馬達轉矩 & 速度/ Gear Motor Torque & Speed

	減速比 Reduction ratio	1/5	1/18	1/20	1/25	1/66	1/77	1/90	1/110	1/136	1/246	1/336	1/393	1/484	1/597	1/735	1/1079	1/1475	1/2124	1/3968	
12V	定格扭力 Rated torque (gf-cm)	170	560	650	820	1800	2100	2450	3000	3700	5000	5000	5000	5000	5000	5000	6000	6000	6000	6000	
	定格轉速 Rated speed (rpm)	1500	400	340	280	105	94	80	65	53	29	22	19	15.5	12.5	10	7.1	5.3	3.8	2	
24V	定格扭力 Rated torque (gf-cm)	190	640	750	930	2000	2400	2800	3500	4000	5000	5000	5000	5000	5000	5000	6000	6000	6000	6000	
	定格轉速 Rated speed (rpm)	1600	420	350	290	110	98	84	68	55	31	23	20	16	13	10.5	7.4	5.5	3.9	2	
	軸心迴轉方向 Rotation direction	CW																			
	長度 Length (L)	23.3	29.5		35.7				41.9				48.1								

### 馬達單體型式/ Motor Data

定格電壓 Rated volt (V)	定格扭力 Rated torque (gf-cm)	定格轉速 Rated speed (rpm)	定格電流 Rated current (mA)	無負荷轉速 No load speed (rpm)	無負荷電流 No load current (mA)	定格出力 Rated output (W)	重量 Weight (g)
12	46	7230	$\leq$ 500	9000	$\leq$ 120	3.41	43
24	53	7550	$\leq$ 300	9000	$\leq$ 80	4.11	43

### 馬達單體特性/ Motor Characteristics

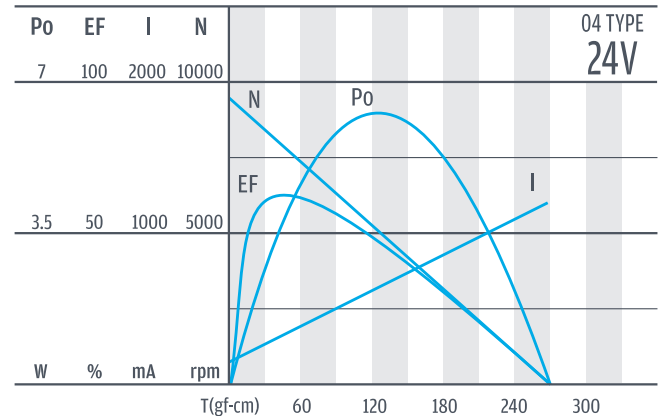
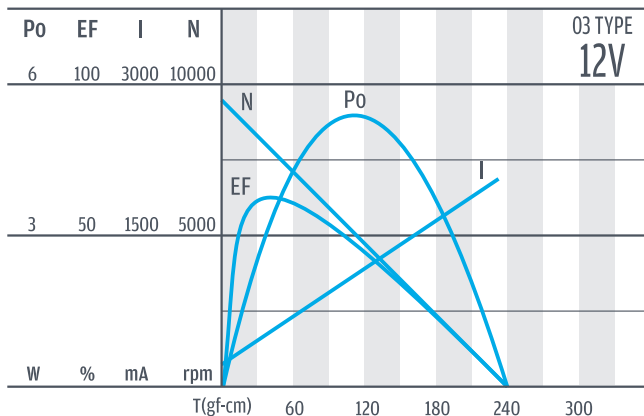



IG

# IG-22CGM

## 05 & 06 TYPE



Right Angle

### 外形尺寸/ Appearance Size

視圖方向僅供參考 / The position of the screw hole and motor terminal in the photo is only for reference.

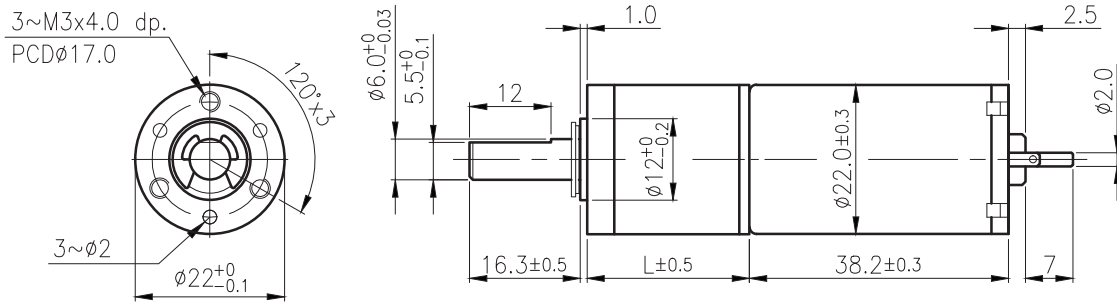

unit:mm

RA

### 齒輪箱馬達轉矩 & 速度/ Gear Motor Torque & Speed

減速比 Reduction ratio	1/5	1/18	1/20	1/25	1/66	1/77	1/90	1/110	1/136	1/246	1/336	1/393	1/484	1/597	1/735	1/1079	1/1475	1/2124	1/3968		
12V 定格扭力 Rated torque (gf-cm)	260	850	1000	1200	2700	3200	3700	4000	4000	5000	5000	5000	5000	5000	5000	6000	6000	6000	6000		
12V 定格轉速 Rated speed (rpm)	1500	400	340	280	105	92	79	64	52	29.4	22.4	19.6	16	12.9	10.5	7.4	5.5	4	2		
24V 定格扭力 Rated torque (gf-cm)	260	850	1000	1200	2700	3200	3700	4000	4000	5000	5000	5000	5000	5000	5000	6000	6000	6000	6000		
24V 定格轉速 Rated speed (rpm)	1550	410	350	290	110	95	81	67	56	31	23	20	16.3	13.1	10.7	7.5	5.6	4	2		
軸心迴轉方向 Rotation direction	CW																				
長度 Length (L)	23.3		29.5		35.7				41.9				48.1								

RB

WG

### 馬達單體型式/ Motor Data

定格電壓 Rated volt (V)	定格扭力 Rated torque (gf-cm)	定格轉速 Rated speed (rpm)	定格電流 Rated current (mA)	無負荷轉速 No load speed (rpm)	無負荷電流 No load current (mA)	定格出力 Rated output (W)	重量 Weight (g)
12	70	7100	$\leq$ 700	9000	$\leq$ 190	5.1	51
24	70	7400	$\leq$ 360	9000	$\leq$ 120	5.3	51

PG

### 馬達單體特性/ Motor Characteristics

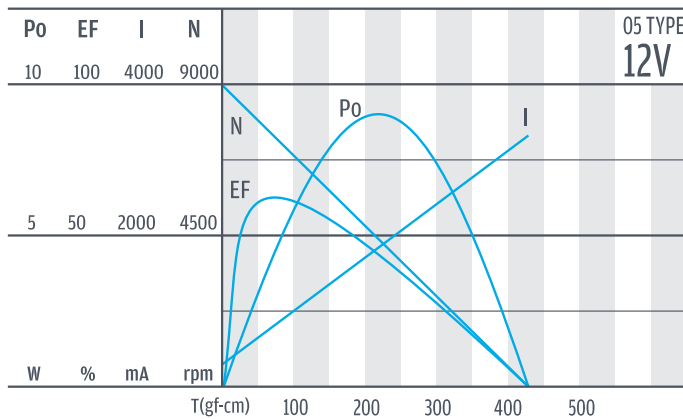

Encoder

Driver

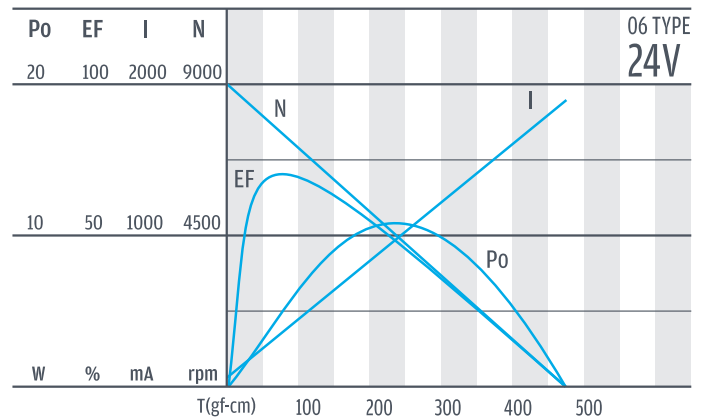

# IG-22P



## 外形尺寸 & 馬達齒鋸合尺寸 / Appearance Size & Pinion Assembly Dimension

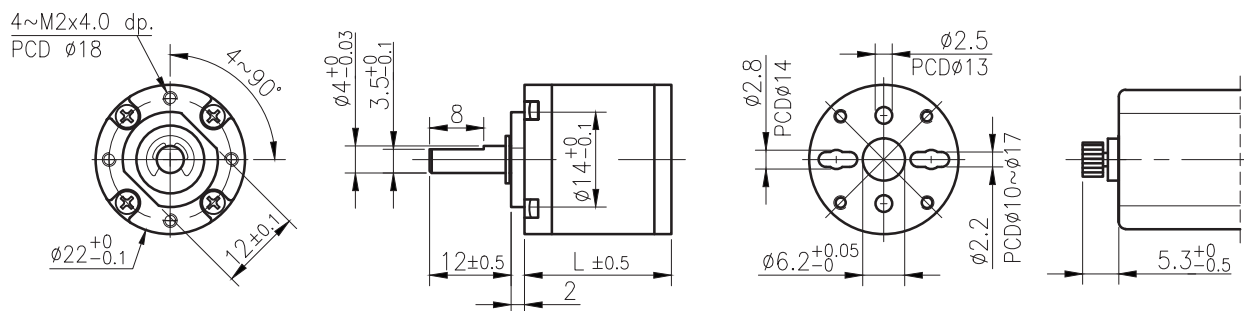

unit:mm

## 產品規格/ Product Specifications

外殼材質 Housing material	輸出軸承型式 Output shaft bearing	徑向負荷 Radial load (10mm from flange)	軸向負荷 Shaft axial load	主軸承受壓入力 Shaft press fit force	徑向間隙 Radial play of shaft	軸向間隙 Thrust play of shaft	背隙(無負荷時) Backlash, at no-load
粉末金屬 Powder Metal	含油軸承 Sleeve bearing	$\leq 0.8$ kgf	$\leq 0.6$ kgf	$\leq 5$ kgf	$\leq 0.08$ mm	$\leq 0.2$ mm	$\leq 3^\circ$
粉末金屬 Powder Metal	滾珠軸承 Ball bearings	$\leq 1$ kgf	$\leq 0.6$ kgf	$\leq 5$ kgf	$\leq 0.05$ mm	$\leq 0.2$ mm	$\leq 3^\circ$

## 馬達齒輪型式/ Pinion Specifications

模數 Module	齒數 No. of teeth	壓力角 Pressure angle	孔徑 (mm) Hole diameter	減速比 Reduction ratio
0.3	13	$20^\circ$	$\phi 1.98$	1/4, 1/16, 1/19, 1/62, 1/72, 1/84, 1/104, 1/231, 1/270 1/316, 1/370, 1/455, 1/1014, 1/1249, 1/1621, 1/1996
0.3	16	$20^\circ$	$\phi 1.98$	1/14, 1/53, 1/198, 1/742

## 標準減速比型式/ Gearboxes Specifications

減速比 Reduction ratio	1/4	1/14	1/16	1/19	1/53	1/62	1/72	1/84	1/104	1/198	1/231	1/270	1/316	1/370	1/455	1/742	1/1014	1/1249	1/1621	1/1996
定格容許扭力 (kgf-cm max.) Rated tolerance torque	0.8	1.3	1.3	1.3	1.7	1.7	1.7	1.7	1.7	2	2	2	2	2	2.5	2.5	2.5	2.5	2.5	2.5
瞬間容許扭力 (kgf-cm) Max momentary tolerance torque	2.4	3.9	3.9	3.9	5.1	5.1	5.1	5.1	5.1	6	6	6	6	6	7.5	7.5	7.5	7.5	7.5	7.5
效率 Efficiency	80%	70%	70%	70%	60%	60%	60%	60%	60%	50%	50%	50%	50%	50%	50%	40%	40%	40%	40%	40%
長度 (L) Length (L)	14.40	18.05	18.05	18.05	21.70	21.70	21.70	21.70	21.70	25.35	25.35	25.35	25.35	25.35	29	29	29	29	29	29
重量 (含油軸承) Weight (g) / Sleeve bearing	27	31	31	31	35	35	35	35	35	60	60	60	60	60	65	65	65	65	65	65
重量 (滾珠軸承) Weight (g) / Ball bearings	26	30	30	30	34	34	34	34	34	59	59	59	59	59	64	64	64	64	64	64

- 使用相對溼度：20%~85%RH  
Operating relative humidity
- 使用溫度範圍：-10°C~+60°C  
Operating temperature range

IG

# IG-22PGM

## 03 & 04 TYPE



Right Angle

### 外形尺寸/ Appearance Size

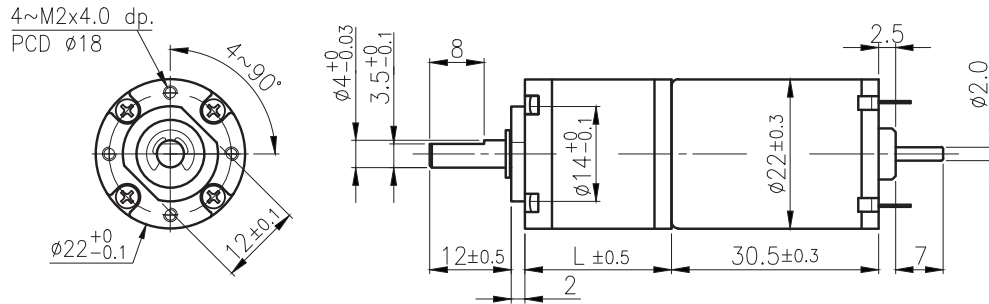

unit:mm

RA

RB

### 齒輪箱馬達轉矩 & 速度/ Gear Motor Torque & Speed

減速比 Reduction ratio	1/4	1/14	1/16	1/19	1/53	1/62	1/72	1/84	1/104	1/198	1/231	1/270	1/316	1/370	1/455	1/742	1/1014	1/1249	1/1621	1/1996
12V 定格扭力 Rated torque (gf-cm)	100	300	350	410	970	1100	1300	1500	1700	2000	2000	2000	2000	2000	2000	2500	2500	2500	2500	2500
12V 定格轉速 Rated speed (rpm)	1000	340	290	245	90	77	66	56	46	24	21	18	16	13.5	11	7.3	5	4.2	3.3	2.7
24V 定格扭力 Rated torque (gf-cm)	120	360	420	490	1150	1300	1500	1700	1700	2000	2000	2000	2000	2000	2000	2500	2500	2500	2500	2500
24V 定格轉速 Rated speed (rpm)	1000	330	280	240	89	76	65	55	46	24	21	18	16	13.5	11	7.3	5	4.2	3.3	2.7
軸心迴轉方向 Rotation direction	CW																			
長度 Length (L)	14.40	18.05	21.70	25.35	29															

WG

PG

### 馬達單體型式/ Motor Data

定格電壓 Rated volt (V)	定格扭力 Rated torque (gf-cm)	定格轉速 Rated speed (rpm)	定格電流 Rated current (mA)	無負荷轉速 No load speed (rpm)	無負荷電流 No load current (mA)	定格出力 Rated output (W)	重量 Weight (g)
12	31	4790	≤ 240	6000	≤ 80	1.52	43
24	37	4710	≤ 145	6000	≤ 55	1.79	43

### 馬達單體特性/ Motor Characteristics

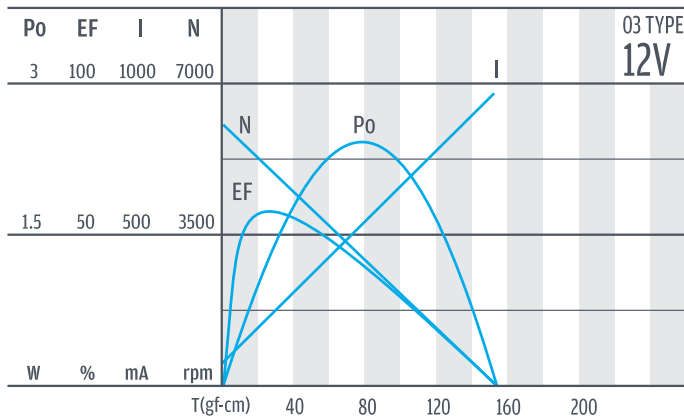

Encoder

Driver

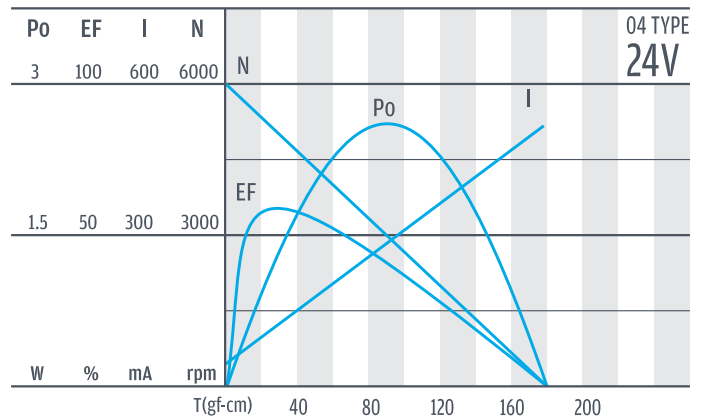

# IG-22PGM

## 41 & 42 TYPE



### 外形尺寸/ Appearance Size

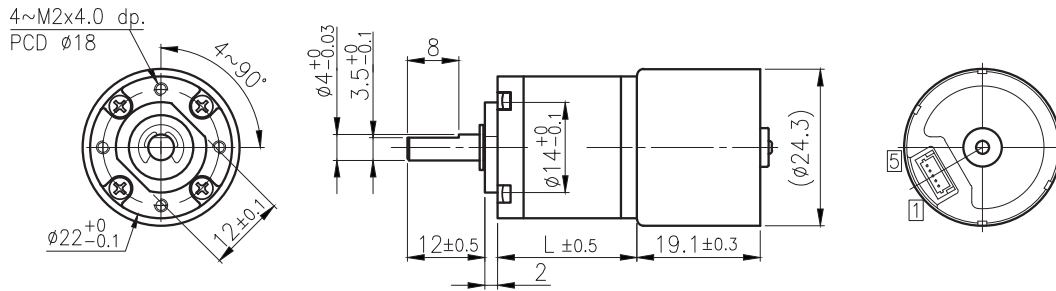

unit:mm

### 齒輪箱馬達轉矩 & 速度/ Gear Motor Torque & Speed

減速比 Reduction ratio		1/4	1/14	1/16	1/19	1/53	1/62	1/72	1/84	1/104	1/198	1/231	1/270	1/316	1/370	1/455	1/742	1/1014	1/1249	1/1621	1/1996
12V	定格扭力 Rated torque (gf-cm)	100	290	345	400	940	1100	1290	1500	1700	2000	2000	2000	2000	2000	2000	2500	2500	2500	2500	2500
	定格轉速 Rated speed (rpm)	1200	380	320	275	100	85	74	63	51	28	25	22	18	16	13	8	6.1	5.1	4	3.4
24V	定格扭力 Rated torque (gf-cm)	95	270	320	375	885	1030	1200	1400	1700	2000	2000	2000	2000	2000	2000	2500	2500	2500	2500	2500
	定格轉速 Rated speed (rpm)	1437	448	383	328	119	102	87	75	62	35	31	28	25	21.5	17.6	10.9	8	6.5	5.2	4.3
軸心迴轉方向 Rotation direction		CW																			
長度 Length (L)		14.40	18.05				21.70						25.35							29	

### 馬達單體型式/ Motor Data

定格電壓 Rated volt (V)	定格扭力 Rated torque (gf-cm)	定格轉速 Rated speed (rpm)	定格電流 Rated current (mA)	無負荷轉速 No load speed (rpm)	無負荷電流 No load current (mA)	定格出力 Rated output (W)	重量 Weight (g)
12	30	5340	≤ 310	7400	≤ 180	1.65	28
24	28	6300	≤ 180	8700	≤ 140	1.81	28

### 馬達單體特性/ Motor Characteristics

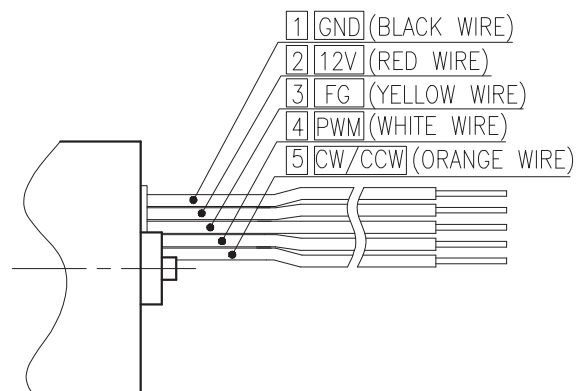
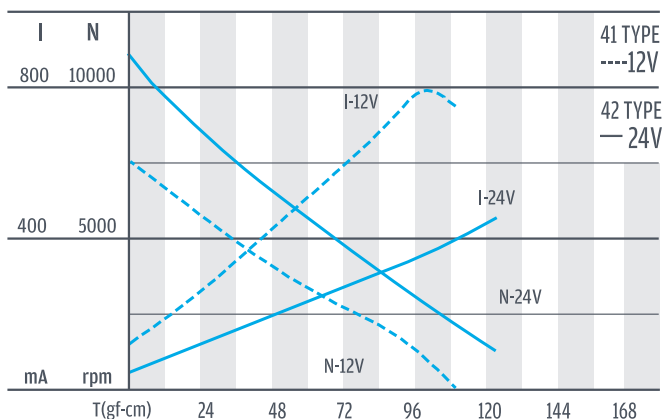

IG

# IG-28



Right Angle

## 外形尺寸 & 馬達齒鉚合尺寸 / Appearance Size & Pinion Assembly Dimension

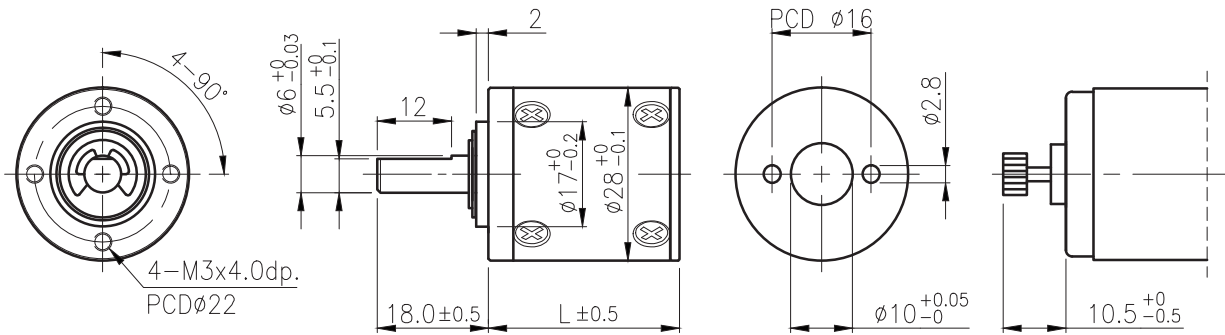

unit:mm

RA

RB

## 產品規格/ Product Specifications

外殼材質 Housing material	輸出軸承型式 Output shaft bearing	徑向負荷 Radial load (10mm from flange)	軸向負荷 Shaft axial load	主軸承受壓入力 Shaft press fit force	徑向間隙 Radial play of shaft	軸向間隙 Thrust play of shaft	背隙 (無負荷時) Backlash, at no-load
金屬 Metal	含油軸承 Sleeve bearings	≤ 3 kgf	≤ 2.5 kgf	≤ 10 kgf	≤ 0.08 mm	≤ 0.3 mm	≤ 2.5°
金屬 Metal	滾珠軸承 Ball bearings	≤ 3.5 kgf	≤ 2.5 kgf	≤ 10 kgf	≤ 0.05 mm	≤ 0.3 mm	≤ 2.5°

WG

## 馬達齒輪型式/ Pinion Specifications

模數 Module	齒數 No. of teeth	壓力角 Pressure angle	孔徑 (mm) Hole diameter	減速比 Reduction ratio
0.5	11	20°	$\phi$ 2.28	1/5, 1/19, 1/27, 1/71, 1/100, 1/139, 1/264, 1/516, 1/721
0.5	17	20°	$\phi$ 2.28	1/4, 1/14, 1/51, 1/189
0.5	8	20°	$\phi$ 2.28	1/35, 1/939

PG

## 標準減速比型式/ Gearboxes Specifications

減速比 Reduction ratio	1/4	1/5	1/14	1/19	1/27	1/35	1/51	1/71	1/100	1/139	1/189	1/264	1/516	1/721	1/939
定格容許扭力 (kgf-cm max.) Rated tolerance torque	2	2	3	3	4	4	6	6	8	8	10	10	10	10	10
瞬間容許扭力 (kgf-cm) Max momentary tolerance torque	6	6	9	9	12	12	18	18	24	24	30	30	30	30	30
效率 Efficiency	80%	80%	70%	70%	70%	70%	60%	60%	60%	60%	50%	50%	50%	50%	50%
長度 Length (L)	24.5	24.5	30.9	30.9	30.9	30.9	37.3	37.3	37.3	37.3	43.7	43.7	43.7	43.7	43.7
重量 (含油軸承) Weight (g) /Sleeve bearings	71	71	81	81	81	81	94	94	94	94	108	108	108	108	108
重量 (滾珠軸承) Weight (g) /Ball bearings	70	70	80	80	80	80	93	93	93	93	107	107	107	107	107

Encoder

Driver

- 使用相對溼度：20%~85%RH  
Operating relative humidity
- 使用溫度範圍：-10°C~+60°C  
Operating temperature range

# IG-28GM

## 03 & 04 TYPE



### 外形尺寸/ Appearance Size

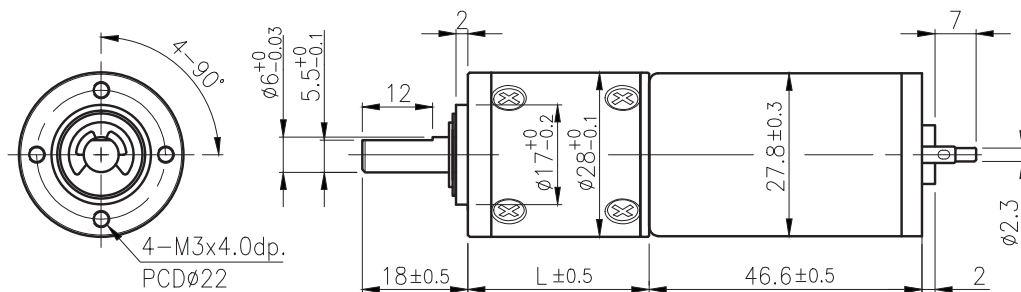

unit:mm

### 齒輪箱馬達轉矩 & 速度/ Gear Motor Torque & Speed

		減速比 Reduction ratio	1/5	1/14	1/19	1/27	1/35	1/51	1/71	1/100	1/139	1/189	1/264	1/516	1/721	1/939
12V	定格扭力 Rated torque (kgf-cm)	0.32	0.75	1	1.4	1.9	2.4	3.3	4.7	6.6	7.4	10	10	10	10	
	定格轉速 Rated speed (rpm)	1000	375	270	193	148	102	73	52	37.3	27.5	19.7	10.5	7.5	5.7	
24V	定格扭力 Rated torque (kgf-cm)	0.38	0.9	1.2	1.7	2.3	2.8	4	5.6	7.8	8.8	10	10	10	10	
	定格轉速 Rated speed (rpm)	990	370	265	191	147	101	72	51.5	36.9	27.2	19.3	10.4	7.4	5.7	
軸心迴轉方向 Rotation direction		CCW														
長度 Length (L)		24.5			30.9				37.3					43.7		

### 馬達單體型式/ Motor Data

定格電壓 Rated volt (V)	定格扭力 Rated torque (gf-cm)	定格轉速 Rated speed (rpm)	定格電流 Rated current (A)	無負荷轉速 No load speed (rpm)	無負荷電流 No load current (A)	定格出力 Rated output (W)	重量 Weight (g)
12	79	5200	≤0.5	6000	≤0.13	4.22	93
24	94	5140	≤0.3	6000	≤0.08	4.96	91

### 馬達單體特性/ Motor Characteristics

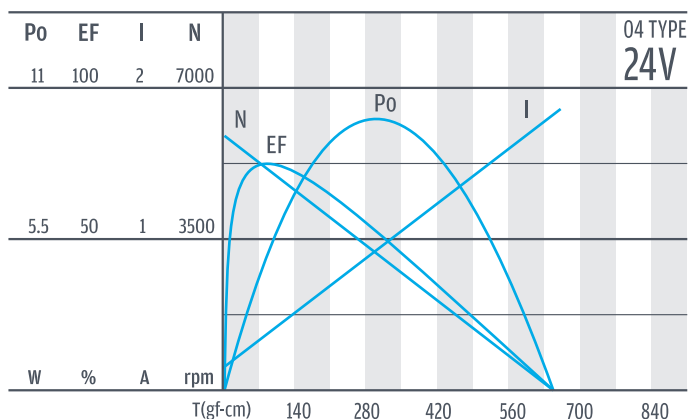
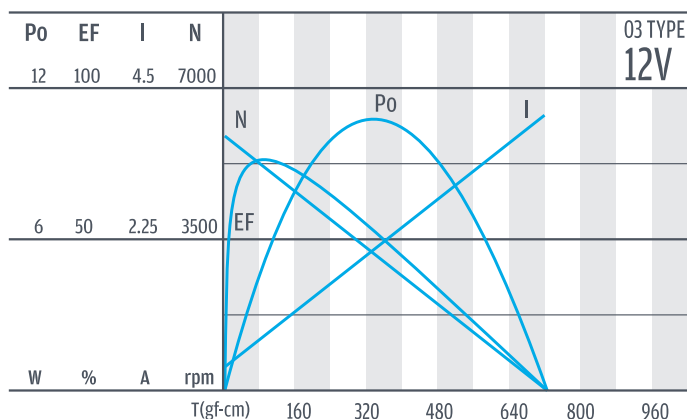

IG

# IG-30



Right Angle

## 外形尺寸 & 馬達齒鉤尺寸 / Appearance Size & Pinion Assembly Dimension

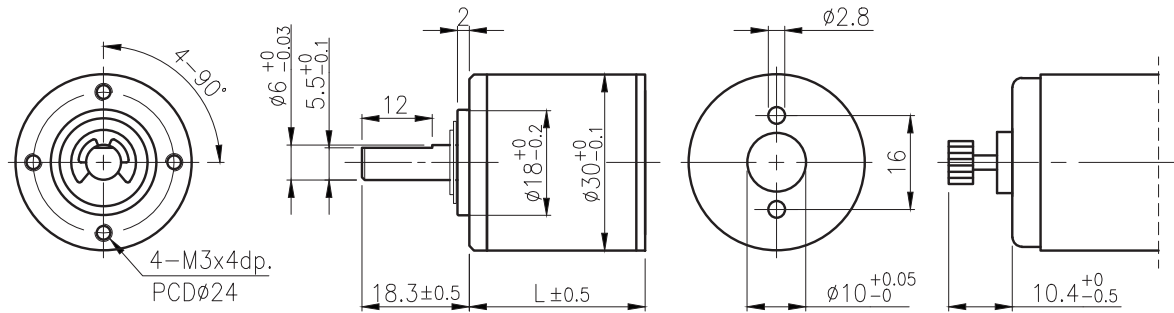

unit:mm

RA

## 產品規格 / Product Specifications

外殼材質 Housing material	輸出軸承型式 Output shaft bearing	徑向負荷 Radial load (10mm from flange)	軸向負荷 Shaft axial load	主軸承受壓力 Shaft press fit force	徑向間隙 Radial play of shaft	軸向間隙 Thrust play of shaft	背隙 (無負荷時) Backlash, at no-load
金屬 Metal	含油軸承 Sleeve bearing	≤ 3 kgf	≤ 2.5 kgf	≤ 10 kgf	≤ 0.08 mm	≤ 0.3 mm	≤ 2.5°
金屬 Metal	滾珠軸承 Ball bearings	≤ 3.5 kgf	≤ 2.5 kgf	≤ 10 kgf	≤ 0.05 mm	≤ 0.3 mm	≤ 2.5°

RB

## 馬達齒輪型式 / Pinion Specifications

模數 Module	齒數 No. of teeth	壓力角 Pressure angle	孔徑 (mm) Hole diameter	減速比 Reduction ratio
0.5	11	20°	Ø2.28, Ø2.48, Ø2.98	1/5, 1/19, 1/27, 1/71, 1/100, 1/139, 1/264, 1/516, 1/721
0.5	17	20°	Ø2.28, Ø2.48, Ø2.98	1/4, 1/14, 1/51, 1/189
0.5	8	20°	Ø2.28	1/35, 1/939

WG

## 標準減速比型式 / Gearboxes Specifications

減速比 Reduction ratio	1/4	1/5	1/14	1/19	1/27	1/35	1/51	1/71	1/100	1/139	1/189	1/264	1/516	1/721	1/939
定格容許扭力 (kgf-cm max.) Rated tolerance torque	2	2	3	3	4	4	6	6	8	8	10	10	10	10	10
瞬間容許扭力 (kgf-cm) Max momentary tolerance torque	6	6	9	9	12	12	18	18	24	24	30	30	30	30	30
效率 Efficiency	80%	80%	70%	70%	70%	70%	60%	60%	60%	60%	50%	50%	50%	50%	50%
長度 Length (L)	23.6	23.6	30	30	30	30	36.4	36.4	36.4	36.4	42.8	42.8	42.8	42.8	42.8
重量 (含油軸承) Weight (g) / Sleeve bearing	79	79	92	92	92	92	107	107	107	107	122	122	122	122	122
重量 (滾珠軸承) Weight (g) / Ball bearings	78	78	91	91	91	91	106	106	106	106	121	121	121	121	121

PG

Encoder

Driver

- 使用相對溼度：20%~85%RH  
Operating relative humidity
- 使用溫度範圍：-10°C~+60°C  
Operating temperature range



# IG-30GM

## 03 & 04 TYPE



外形尺寸/ Appearance Size

視圖方向僅供參考 / The position of the screw hole and motor terminal in the photo is only for reference.

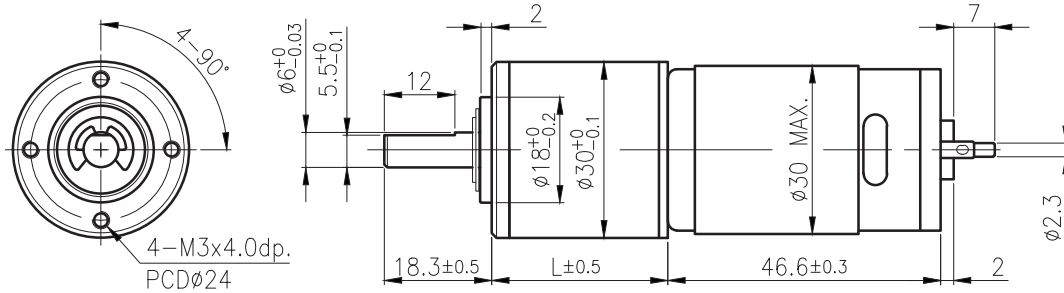

unit:mm

齒輪箱馬達轉矩 & 速度/ Gear Motor Torque & Speed

		減速比 Reduction ratio	1/5	1/14	1/19	1/27	1/35	1/51	1/71	1/100	1/139	1/189	1/264	1/516	1/721	1/939	
12V	定格扭力 Rated torque (kgf-cm)	0.45	1.1	1.5	2.1	2.7	3.4	4.7	6.6	8	10	10	10	10	10	10	
	定格轉速 Rated speed (rpm)	1120	430	310	221	170	117	83	60	45	32	25	13.2	9.6	7.3		
24V	定格扭力 Rated torque (kgf-cm)	0.54	1.2	1.7	2.4	3.1	4	5.5	7.8	8	10	10	10	10	10		
	定格轉速 Rated speed (rpm)	1150	445	320	229	176	121	87	62	46	34.5	26	13.5	9.8	7.3		
軸心迴轉方向 Rotation direction		CCW															
長度 Length (L)		23.6	30			36.4			42.8								

馬達單體型式/ Motor Data

定格電壓 Rated volt (V)	定格扭力 Rated torque (gf-cm)	定格轉速 Rated speed (rpm)	定格電流 Rated current (A)	無負荷轉速 No load speed (rpm)	無負荷電流 No load current (A)	定格出力 Rated output (W)	重量 Weight (g)
12	110	5950	≤0.9	7200	≤0.15	7.0	110
24	130	6160	≤0.5	7200	≤0.08	8.5	110

馬達單體特性/ Motor Characteristics

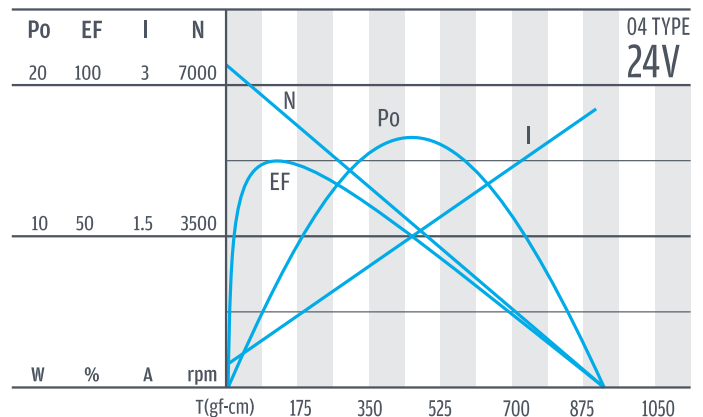
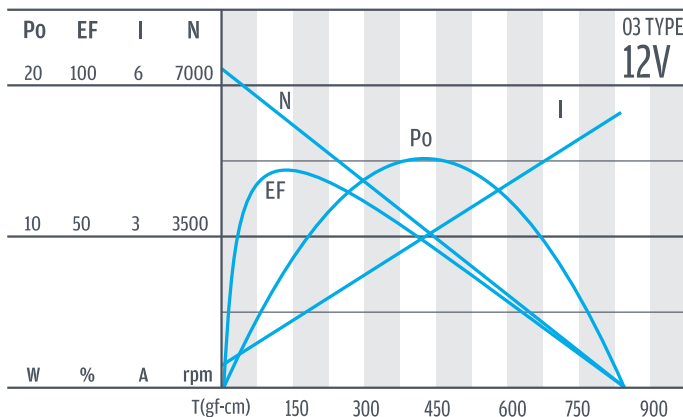



# IG-32GM

## 01 & 02 TYPE



### 外形尺寸/ Appearance Size

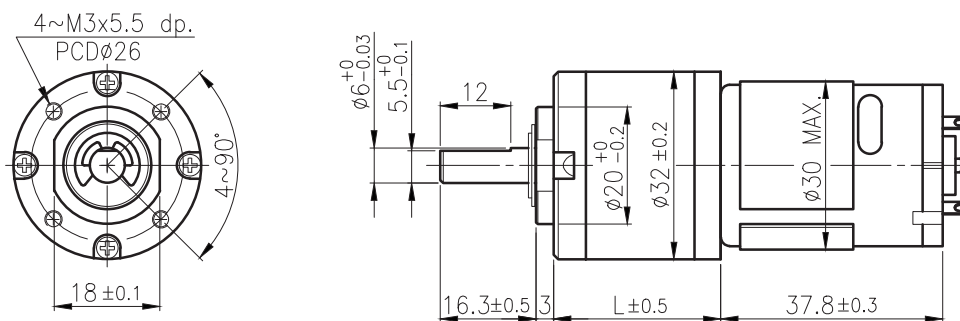

unit:mm

### 齒輪箱馬達轉矩 & 速度/ Gear Motor Torque & Speed

減速比 Reduction ratio	1/5	1/14	1/19	1/27	1/35	1/51	1/71	1/100	1/139	1/189	1/264	1/516	1/721	1/939	
12V 定格扭力 Rated torque(kgf-cm)	0.3	0.75	1	1.4	1.9	2.3	3.3	4.6	6.5	7.3	10	12	12	12	
12V 定格轉速 Rated speed (rpm)	995	373	270	195	150	104	74	53	38	28	20	11.2	8.3	6.3	
24V 定格扭力 Rated torque(kgf-cm)	0.3	0.7	1.0	1.4	1.8	2.2	3.1	4.4	6.1	6.9	9.7	12	12	12	
24V 定格轉速 Rated speed (rpm)	990	370	265	191	150	103	74	53	38	28	20	11.2	8.3	6.3	
軸心迴轉方向 Rotation direction	CCW														
長度 Length (L)	20.6		27			33.4					39.8				

### 馬達單體型式/ Motor Data

定格電壓 Rated volt (V)	定格扭力 Rated torque (gf-cm)	定格轉速 Rated speed (rpm)	定格電流 Rated current (A)	無負荷轉速 No load speed (rpm)	無負荷電流 No load current(A)	定格出力 Rated output (W)	重量 Weight (g)
12	78	5290	$\leq$ 0.53	6500	$\leq$ 0.15	4.22	73.0
24	74	5250	$\leq$ 0.25	6500	$\leq$ 0.085	3.97	73.0

### 馬達單體特性/ Motor Characteristics

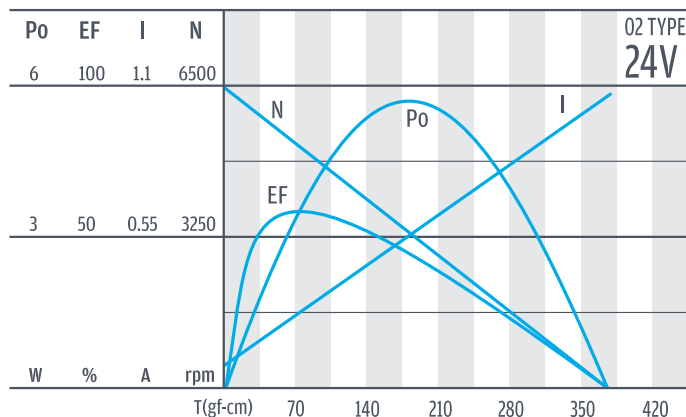
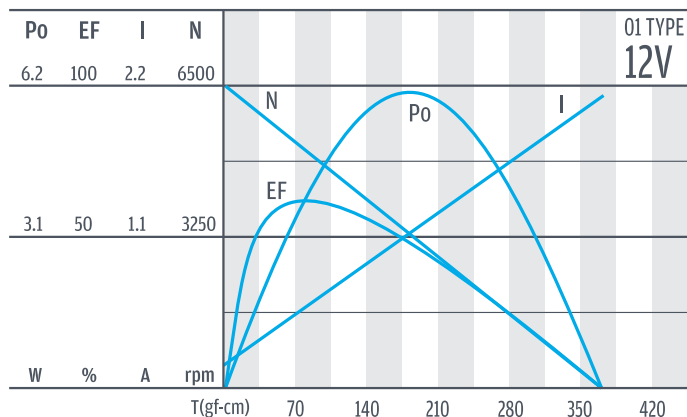

IG

# IG-32GM

## 03 & 04 TYPE

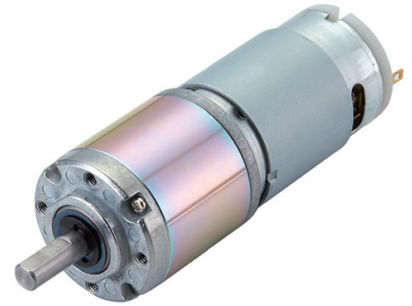

Right Angle

### 外形尺寸/ Appearance Size

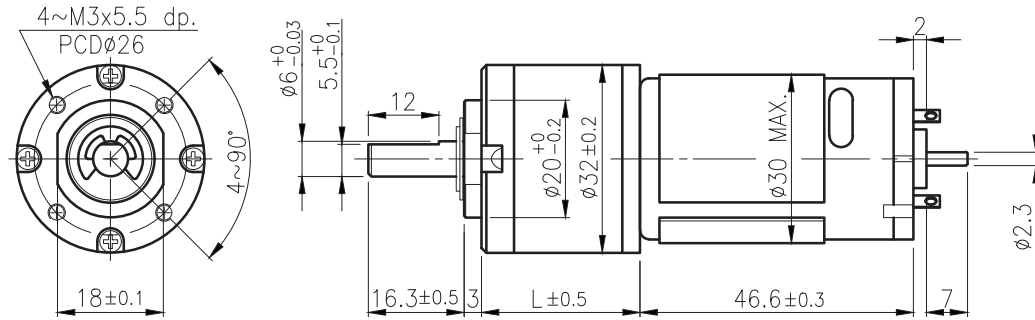

unit:mm

RA

### 齒輪箱馬達轉矩 & 速度/ Gear Motor Torque & Speed

	減速比 Reduction ratio	1/5	1/14	1/19	1/27	1/35	1/51	1/71	1/100	1/139	1/189	1/264	1/516	1/721	1/939	
12V	定格扭力 Rated torque (kgf-cm)	0.45	1.1	1.5	2.1	2.7	3.4	4.7	6.6	9.1	10	12	12	12	12	
	定格轉速 Rated speed (rpm)	1140	430	310	221	170	117	83	60	44	32	24	12.9	9.5	7.2	
24V	定格扭力 Rated torque (kgf-cm)	0.54	1.2	1.7	2.4	3.1	4	5.5	7.8	10	12	12	12	12	12	
	定格轉速 Rated speed (rpm)	1170	445	320	229	176	121	87	62	45	34	25	13	9.6	7.2	
	軸心迴轉方向 Rotation direction	CCW														
	長度 Length (L)	20.6		27			33.4					39.8				

RB

WG

### 馬達單體型式/ Motor Data

定格電壓 Rated volt (V)	定格扭力 Rated torque (gf-cm)	定格轉速 Rated speed (rpm)	定格電流 Rated current (A)	無負荷轉速 No load speed (rpm)	無負荷電流 No load current (A)	定格出力 Rated output (W)	重量 Weight (g)
12	110	5950	$\leq$ 0.9	7200	$\leq$ 0.15	7.0	110
24	130	6160	$\leq$ 0.5	7200	$\leq$ 0.08	8.5	110

PG

### 馬達單體特性/ Motor Characteristics

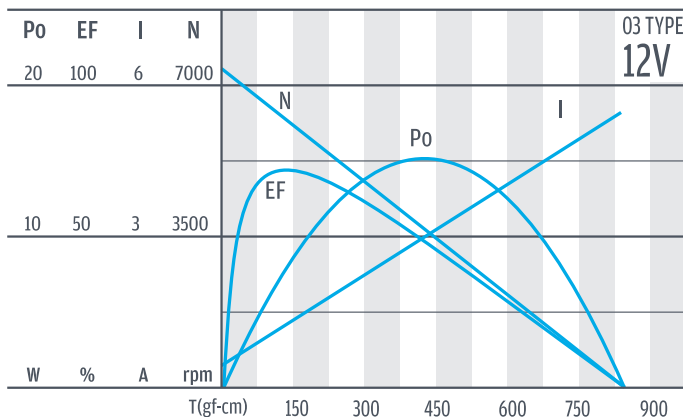

Encoder

Driver

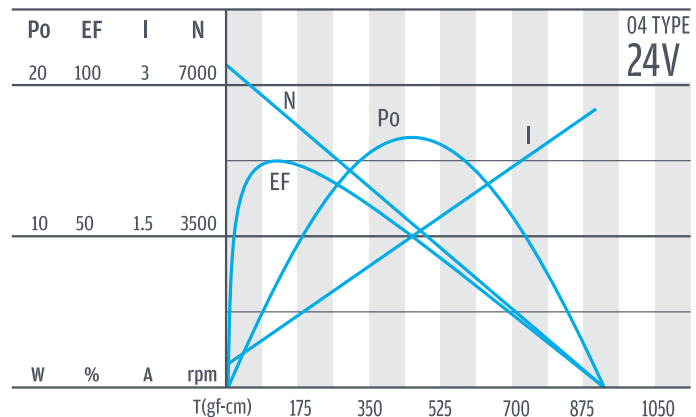

# IG-32H



## 外形尺寸 & 馬達齒鉤尺寸 / Appearance Size & Pinion Assembly Dimension

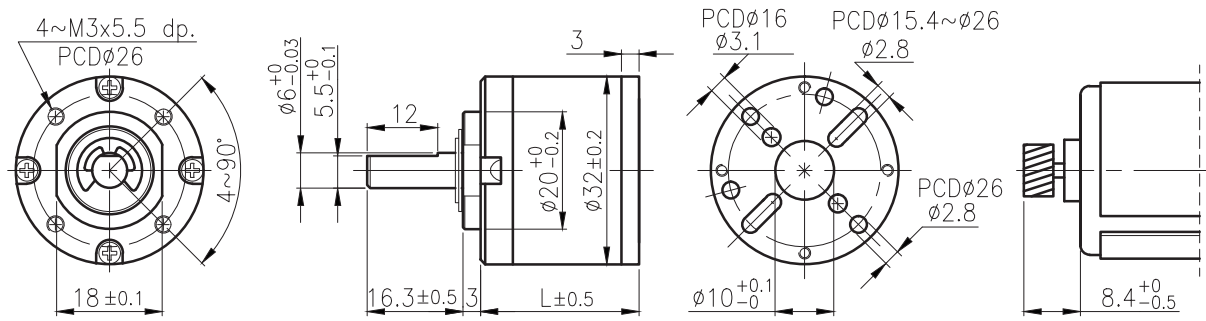

unit:mm

## 產品規格 / Product Specifications

外殼材質 Housing material	輸出軸承型式 Output shaft bearing	徑向負荷 Radial load (10mm from flange)	軸向負荷 Shaft axial load	主軸承受壓力 Shaft press fit force	徑向間隙 Radial play of shaft	軸向間隙 Thrust play of shaft	背隙 (無負荷時) Backlash, at no-load
金屬 Metal	含油軸承 Sleeve bearing	≤ 3 kgf	≤ 2.5 kgf	≤ 10 kgf	≤ 0.08 mm	≤ 0.3 mm	≤ 2.5°
金屬 Metal	滾珠軸承 Ball bearings	≤ 3.5 kgf	≤ 2.5 kgf	≤ 10 kgf	≤ 0.05 mm	≤ 0.3 mm	≤ 2.5°

## 馬達齒輪型式 / Pinion Specifications

模數 Module	齒數 No. of teeth	螺旋角 Helix angle	壓力角 Pressure angle	孔徑 Hole diameter	減速比 Reduction ratio
0.5	11	18° (左, left)	20°	∅2.28, ∅2.48, ∅2.98, ∅3.16	1/18, 1/25, 1/94, 1/132, 1/250, 1/349, 1/683
0.5	17	18° (左, left)	20°	∅2.28, ∅2.48, ∅2.98, ∅3.16	1/13, 1/48, 1/68, 1/180, 1/491
0.5	8	18° (左, left)	20°	∅2.28	1/33, 1/887

## 標準減速比型式 / Gearboxes Specifications

減速比 Reduction ratio	1/13	1/18	1/25	1/33	1/48	1/68	1/94	1/132	1/180	1/250	1/349	1/491	1/683	1/887
定格容許扭力 (kgf-cm max.) Rated tolerance torque	4	4	6	6	8	8	10	10	12	12	12	12	12	12
瞬間容許扭力 (kgf-cm) Max momentary tolerance torque	12	12	18	18	24	24	30	30	36	36	36	36	36	36
效率 Efficiency	70%	70%	70%	70%	60%	60%	60%	60%	50%	50%	50%	50%	50%	50%
長度 Length (L)	27	27	27	27	33.4	33.4	33.4	33.4	39.8	39.8	39.8	39.8	39.8	39.8
重量 (含油軸承) Weight (g) /Sleeve bearing	109	109	109	109	134	134	134	134	160	160	160	160	160	160
重量 (滾珠軸承) Weight (g) /Ball bearings	108	108	108	108	133	133	133	133	159	159	159	159	159	159

- 使用相對溼度：20%~85%RH  
Operating relative humidity
- 使用溫度範圍：-10°C~+60°C  
Operating temperature range

IG

# IG-32P



外形尺寸 & 馬達齒鉤合尺寸 / Appearance Size & Pinion Assembly Dimension

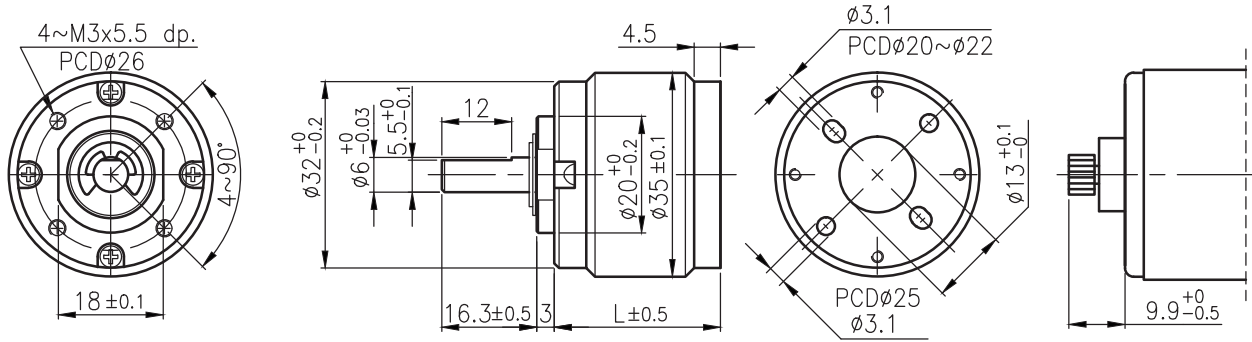

unit:mm

## 產品規格 / Product Specifications

外殼材質 Housing material	輸出軸承型式 Output shaft bearing	徑向負荷 Radial load (10mm from flange)	軸向負荷 Shaft axial load	主軸承受壓入力 Shaft press fit force	徑向間隙 Radial play of shaft	軸向間隙 Thrust play of shaft	背隙 (無負荷時) Backlash, at no-load
粉末金屬 Powder Metal	含油軸承 Sleeve bearing	≤ 3 kgf	≤ 2.5 kgf	≤ 10 kgf	≤ 0.08 mm	≤ 0.3 mm	≤ 2.5°
粉末金屬 Powder Metal	滾珠軸承 Ball bearings	≤ 3.5 kgf	≤ 2.5 kgf	≤ 10 kgf	≤ 0.05 mm	≤ 0.3 mm	≤ 2.5°

## 馬達齒輪型式 / Pinion Specifications

模數 Module	齒數 No. of teeth	壓力角 Pressure angle	孔徑 (mm) Hole diameter	減速比 Reduction ratio
0.5	11	20°	$\phi$ 2.28, $\phi$ 2.48, $\phi$ 2.98, $\phi$ 3.16	1/5, 1/19, 1/27, 1/71, 1/100, 1/139, 1/264, 1/516, 1/721
0.5	17	20°	$\phi$ 2.28, $\phi$ 2.48, $\phi$ 2.98, $\phi$ 3.16	1/4, 1/14, 1/51, 1/189

## 標準減速比型式 / Gearboxes Specifications

減速比 Reduction ratio	1/4	1/5	1/14	1/19	1/27	1/51	1/71	1/100	1/139	1/189	1/264	1/516	1/721
定格容許扭力 (kgf-cm max.) Rated tolerance torque	2	2	4	4	6	8	8	10	10	12	12	12	12
瞬間容許扭力 (kgf-cm) Max momentary tolerance torque	6	6	12	12	18	24	24	30	30	36	36	36	36
效率 Efficiency	80%	80%	70%	70%	70%	60%	60%	60%	60%	50%	50%	50%	50%
長度 Length (L)	22.1	22.1	28.5	28.5	28.5	34.9	34.9	34.9	34.9	41.3	41.3	41.3	41.3
重量 (含油軸承) Weight (g) / Sleeve bearing	109	109	143	143	143	177	177	177	177	211	211	211	211
重量 (滾珠軸承) Weight (g) / Ball bearings	108	108	142	142	142	176	176	176	176	210	210	210	210

- 使用相對溼度：20%~85%RH  
Operating relative humidity
- 使用溫度範圍：-10°C~+60°C  
Operating temperature range

# IG-32PGM

## 01 & 02 TYPE



外形尺寸 / Appearance Size

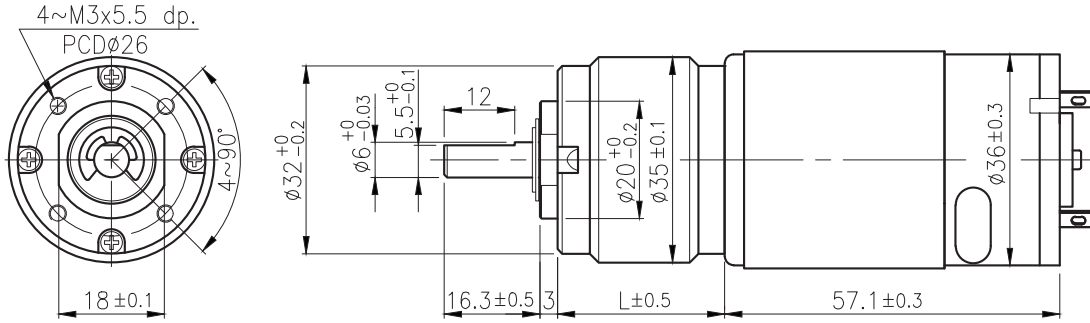

unit:mm

齒輪箱馬達轉矩 & 速度 / Gear Motor Torque & Speed

減速比 Reduction ratio	1/5	1/14	1/19	1/27	1/51	1/71	1/100	1/139	1/189	1/264	1/516	1/721				
12V 定格扭力 Rated torque (kgf-cm)	1	2.4	3.3	4.7	7.6	8	10	10	12	12	12	12				
12V 定格轉速 Rated speed (rpm)	950	359	257	183	97	71.5	52	39	29	21	11	8				
24V 定格扭力 Rated torque (kgf-cm)	1	2.3	3.2	4.5	7.3	8	10	10	12	12	12	12				
24V 定格轉速 Rated speed (rpm)	990	375	268	192	101	74.5	54	40	29.5	22	11.5	8				
軸心迴轉方向 Rotation direction	CCW															
長度 Length (L)	22.1		28.5				34.9				41.3					

馬達單體型式 / Motor Data

定格電壓 Rated volt (V)	定格扭力 Rated torque (gf-cm)	定格轉速 Rated speed (rpm)	定格電流 Rated current (A)	無負荷轉速 No load speed (rpm)	無負荷電流 No load current (A)	定格出力 Rated output (W)	重量 Weight (g)
12	250	4930	≤ 1.6	6000	≤ 0.25	12.80	220
24	240	5150	≤ 0.75	6000	≤ 0.13	12.70	220

馬達單體特性 / Motor Characteristics

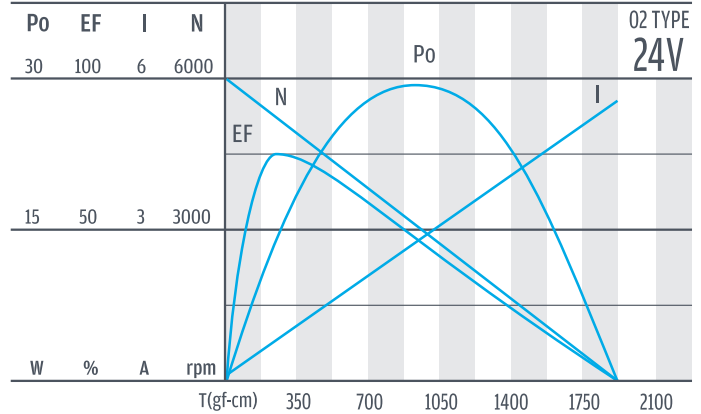
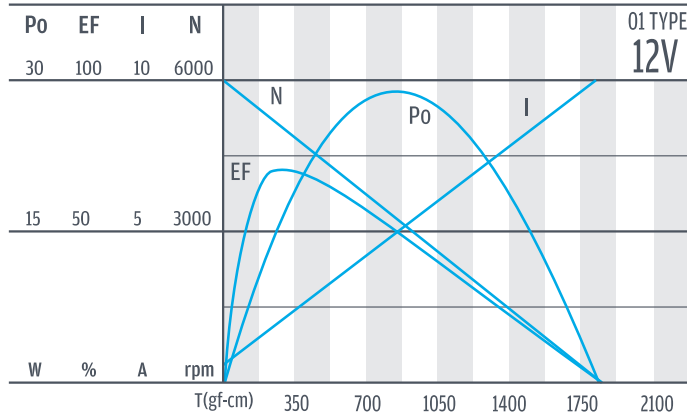



IG

# IG-32PGM

## 41 & 42 TYPE

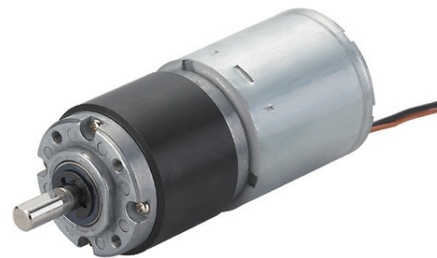

Right Angle

### 外形尺寸/ Appearance Size

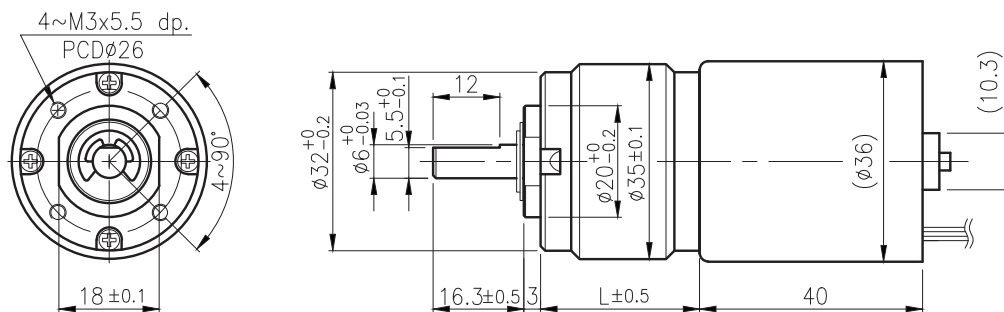

unit:mm

RA

### 齒輪箱馬達轉矩 & 速度/ Gear Motor Torque & Speed

	減速比 Reduction ratio	1/5	1/14	1/19	1/27	1/51	1/71	1/100	1/139	1/189	1/264	1/516	1/721				
12V	定格扭力 Rated torque (kgf-cm)	0.8	1.9	2.6	3.7	6.1	8	10	10	12	12	12	12				
	定格轉速 Rated speed (rpm)	380	140	100	73	38	28	20	15.5	11.5	8.5	4.5	3.4				
24V	定格扭力 Rated torque (kgf-cm)	1	2.4	3.3	4.7	7.6	8	10	10	12	12	12	12				
	定格轉速 Rated speed (rpm)	750	280	200	145	76	54	40	30	23	17	8.5	6.2				
	軸心迴轉方向 Rotation direction	CW															
	長度 Length (L)	22.1		28.5			34.9			41.3							

RB

WG

### 馬達單體型式/ Motor Data

定格電壓 Rated volt (V)	定格扭力 Rated torque (gf-cm)	定格轉速 Rated speed (rpm)	定格電流 Rated current (A)	無負荷轉速 No load speed (rpm)	無負荷電流 No load current (A)	定格出力 Rated output (W)	重量 Weight (g)
12	200	2000	$\leq$ 1.0	2800	$\leq$ 0.35	4.1	145
24	250	3900	$\leq$ 1.23	5000	$\leq$ 0.4	10	145

PG

### 馬達單體特性/ Motor Characteristics

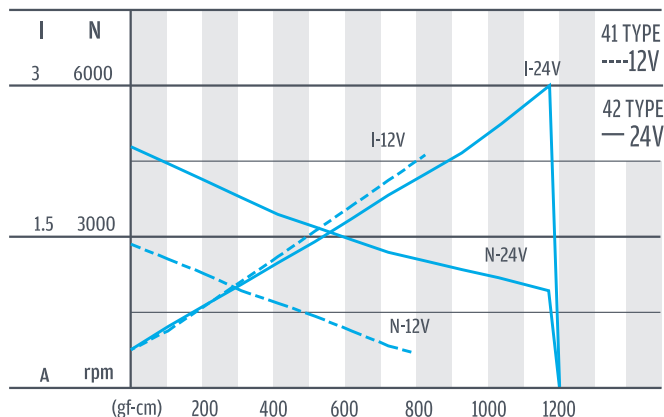

Encoder

Driver

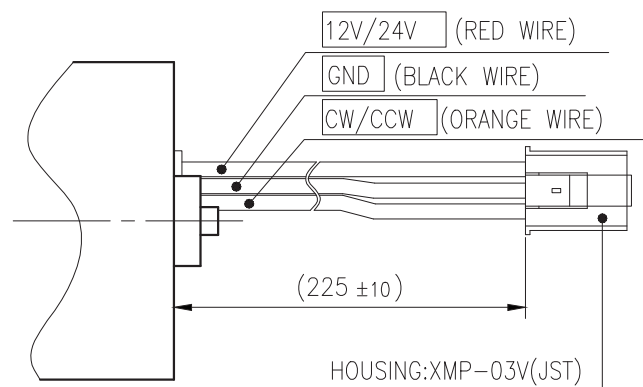

# IG-32PH



## 外形尺寸 & 馬達齒鉤尺寸 / Appearance Size & Pinion Assembly Dimension

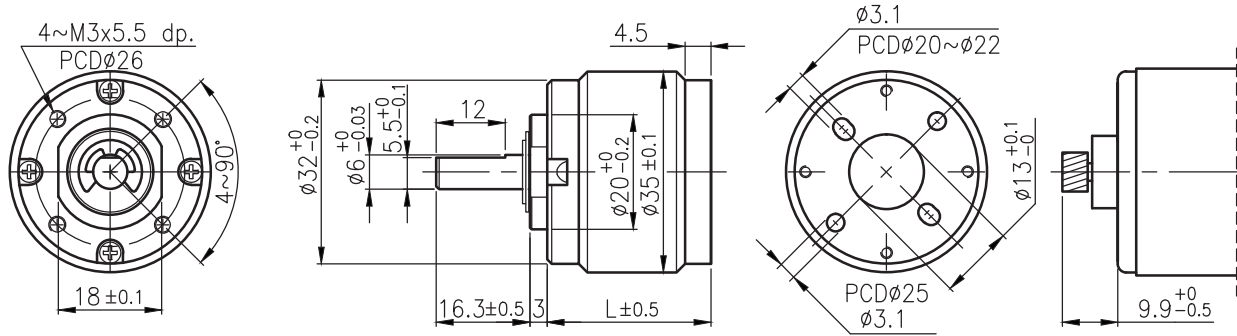

unit:mm

## 產品規格 / Product Specifications

外殼材質 Housing material	輸出軸承型式 Output shaft bearing	徑向負荷 Radial load (10mm from flange)	軸向負荷 Shaft axial load	主軸承受壓力 Shaft press fit force	徑向間隙 Radial play of shaft	軸向間隙 Thrust play of shaft	背隙 (無負荷時) Backlash, at no-load
粉末金屬 Powder Metal	含油軸承 Sleeve bearing	$\leq 3$ kgf	$\leq 2.5$ kgf	$\leq 10$ kgf	$\leq 0.08$ mm	$\leq 0.3$ mm	$\leq 2.5^\circ$
粉末金屬 Powder Metal	滾珠軸承 Ball bearings	$\leq 3.5$ kgf	$\leq 2.5$ kgf	$\leq 10$ kgf	$\leq 0.05$ mm	$\leq 0.3$ mm	$\leq 2.5^\circ$

## 馬達齒輪型式 / Pinion Specifications

模數 Module	齒數 No. of teeth	螺旋角 Helix angle	壓力角 Pressure angle	孔徑 (mm) Hole diameter	減速比 Reduction ratio
0.5	11	18° (左, left)	20°	$\phi$ 3.16	1/18, 1/25, 1/94, 1/132, 1/250, 1/349, 1/683
0.5	17	18° (左, left)	20°	$\phi$ 3.16	1/13, 1/48, 1/68, 1/180, 1/491
0.5	8	18° (左, left)	20°	$\phi$ 2.28	1/33, 1/887

## 標準減速比型式 / Gearboxes Specifications

減速比 Reduction ratio	1/13	1/18	1/25	1/33	1/48	1/68	1/94	1/132	1/180	1/250	1/349	1/491	1/683	1/887
定格容許扭力 (kgf-cm max.) Rated tolerance torque	4	4	6	6	8	8	10	10	12	12	12	12	12	12
瞬間容許扭力 (kgf-cm) Max momentary tolerance torque	12	12	18	18	24	24	30	30	36	36	36	36	36	36
效率 Efficiency	70%	70%	70%	70%	60%	60%	60%	60%	50%	50%	50%	50%	50%	50%
長度 Length (L)	28.5	28.5	28.5	28.5	34.9	34.9	34.9	34.9	41.3	41.3	41.3	41.3	41.3	41.3
重量 (含油軸承) Weight (g) /Sleeve bearing	143	143	143	143	177	177	177	177	211	211	211	211	211	211
重量 (滾珠軸承) Weight (g) /Ball bearings	142	142	142	142	176	176	176	176	210	210	210	210	210	210

- 使用相對溼度：20%~85%RH  
Operating relative humidity
- 使用溫度範圍：-10°C~+60°C  
Operating temperature range

IG

# IG-36P



Right Angle

## 外形尺寸 & 馬達齒鉤合尺寸 / Appearance Size & Pinion Assembly Dimension

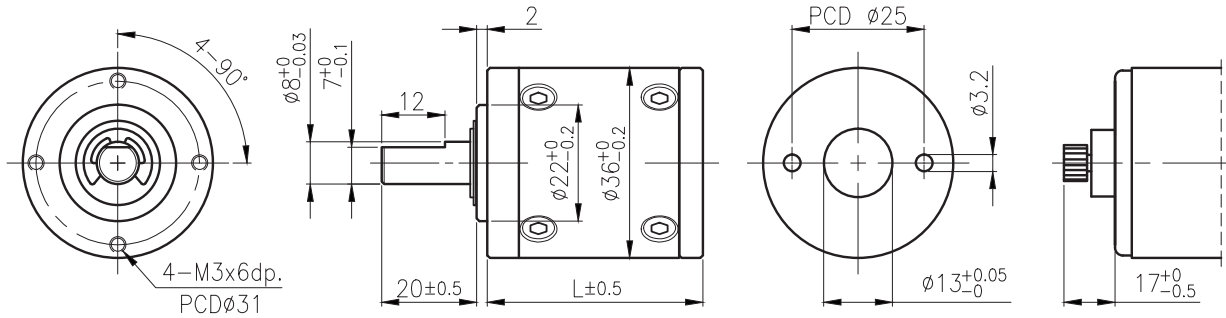

unit:mm

RA

## 產品規格 / Product Specifications

外殼材質 Housing material	輸出軸承型式 Output shaft bearing	徑向負荷 Radial load (10mm from flange)	軸向負荷 Shaft axial load	主軸承受壓入力 Shaft press fit force	徑向間隙 Radial play of shaft	軸向間隙 Thrust play of shaft	背隙 (無負荷時) Backlash, at no-load
粉末金屬 Powder Metal	含油軸承 Sleeve bearing	≤ 5 kgf	≤ 3 kgf	≤ 15 kgf	≤ 0.08 mm	≤ 0.3 mm	≤ 3°
粉末金屬 Powder Metal	滾珠軸承 Ball bearings	≤ 8 kgf	≤ 3 kgf	≤ 15 kgf	≤ 0.05 mm	≤ 0.3 mm	≤ 3°

RB

## 馬達齒輪型式 / Pinion Specifications

模數 Module	齒數 No. of teeth	壓力角 Pressure angle	孔徑 (mm) Hole diameter	減速比 Reduction ratio
0.6	11	20°	Ø3.16	1/5, 1/19, 1/27, 1/71, 1/100, 1/139, 1/264, 1/516, 1/721
0.6	17	20°	Ø3.16	1/4, 1/14, 1/51, 1/189

WG

## 標準減速比型式 / Gearboxes Specifications

減速比 Reduction ratio	1/4	1/5	1/14	1/19	1/27	1/51	1/71	1/100	1/139	1/189	1/264	1/516	1/721
定格容許扭力 (kgf-cm max.) Rated tolerance torque	3	3	8	8	10	18	18	20	20	25	25	30	30
瞬間容許扭力 (kgf-cm) Max momentary tolerance torque	9	9	24	24	30	54	54	60	60	75	75	90	90
效率 Efficiency	80%	80%	70%	70%	70%	60%	60%	60%	60%	50%	50%	50%	50%
長度 (L) Length (L)	33.1	33.1	41.8	41.8	41.8	50.5	50.5	50.5	50.5	59.2	59.2	59.2	59.2
重量 (含油軸承) Weight (g) /Sleeve bearing	130	130	170	170	170	210	210	210	210	250	250	250	250
重量 (滾珠軸承) Weight (g) /Ball bearings	132	132	172	172	172	212	212	212	212	252	252	252	252

PG

Encoder

Driver

- 使用相對溼度：20%~85%RH  
Operating relative humidity
- 使用溫度範圍：-10°C~+60°C  
Operating temperature range

# IG-36PGM

## 01 & 02 TYPE



### 外形尺寸/ Appearance Size

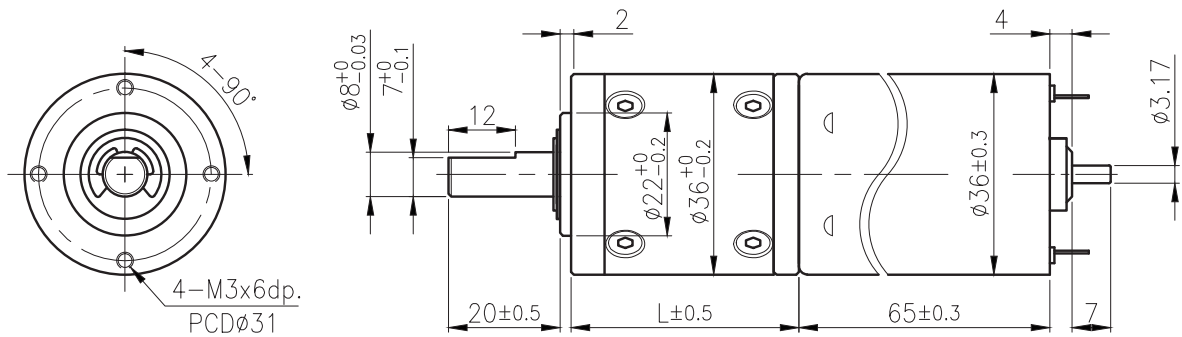

unit:mm

### 齒輪箱馬達轉矩 & 速度/ Gear Motor Torque & Speed

	減速比 Reduction ratio	1/5	1/14	1/19	1/27	1/51	1/71	1/100	1/139	1/189	1/264	1/516	1/721				
12V	定格扭力 Rated torque (kgf-cm)	1.1	2.5	3.6	5	8.2	11.5	16	20	25	25	30	30				
	定格轉速 Rated speed (rpm)	1250	475	340	243	129	92	66	47.2	34.8	25.1	13.2	9.5				
24V	定格扭力 Rated torque (kgf-cm)	1.1	2.7	3.8	5.3	8.7	12	17	20	25	25	30	30				
	定格轉速 Rated speed (rpm)	1240	470	335	240	127	91	65	46.5	34.3	24.8	13	9.4				
	軸心迴轉方向 Rotation direction	CCW															
	長度 Length (L)	33.1	41.8				50.5				59.2						

### 馬達單體型式/ Motor Data

定格電壓 Rated volt (V)	定格扭力 Rated torque (gf-cm)	定格轉速 Rated speed (rpm)	定格電流 Rated current (A)	無負荷轉速 No load speed (rpm)	無負荷電流 No load current (A)	定格出力 Rated output (W)	重量 Weight (g)
12	270	6570	$\leq 2.05$	7500	$\leq 0.3$	18.23	222
24	285	6480	$\leq 1.05$	7500	$\leq 0.21$	18.96	224

### 馬達單體特性/ Motor Characteristics

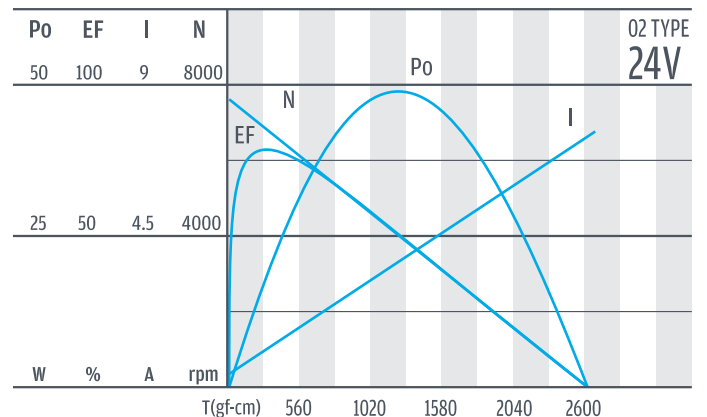
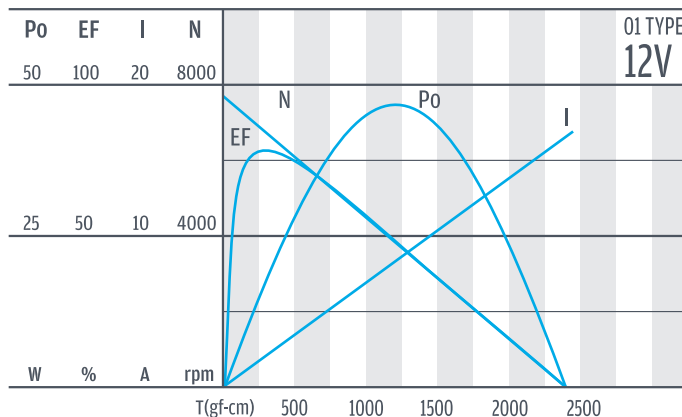

IG

# IG-38P



Right Angle

## 外形尺寸 & 馬達齒鉚合尺寸 / Appearance Size & Pinion Assembly Dimension

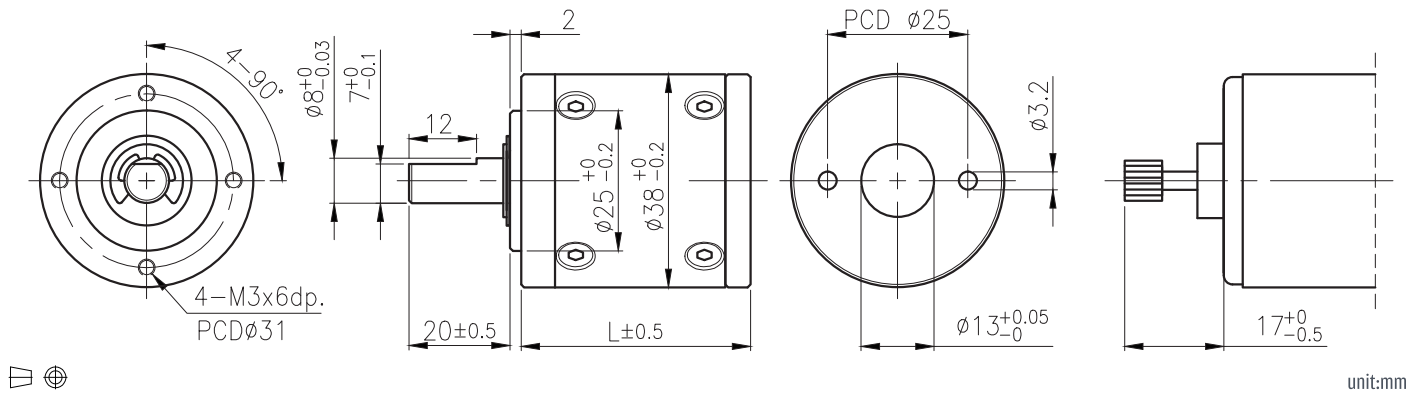

RA

RB

## 產品規格 / Product Specifications

外殼材質 Housing material	輸出軸承型式 Output shaft bearing	徑向負荷 Radial load (10mm from flange)	軸向負荷 Shaft axial load	主軸承受壓入力 Shaft press fit force	徑向間隙 Radial play of shaft	軸向間隙 Thrust play of shaft	背隙 (無負荷時) Backlash, at no-load
粉末金屬 Powder Metal	含油軸承 Sleeve bearing	≤ 5 kgf	≤ 3 kgf	≤ 15 kgf	≤ 0.08 mm	≤ 0.3 mm	≤ 3°
粉末金屬 Powder Metal	滾珠軸承 Ball bearings	≤ 8 kgf	≤ 3 kgf	≤ 15kgf	≤ 0.05 mm	≤ 0.3 mm	≤ 3°

WG

## 馬達齒輪型式 / Pinion Specifications

模數 Module	齒數 No. of teeth	壓力角 Pressure angle	孔徑 (mm) Hole diameter	減速比 Reduction ratio
0.6	11	20°	∅3.16	1/5, 1/19, 1/27, 1/71, 1/100, 1/139, 1/264, 1/516, 1/721
0.6	17	20°	∅3.16	1/4, 1/14, 1/51, 1/189

PG

## 標準減速比型式 / Gearboxes Specifications

減速比 Reduction ratio	1/4	1/5	1/14	1/19	1/27	1/51	1/71	1/100	1/139	1/189	1/264	1/516	1/721
定格容許扭力 (kgf-cm max.) Rated tolerance torque	3	3	8	8	10	18	18	20	20	25	25	30	30
瞬間容許扭力 (kgf-cm) Max momentary tolerance torque	9	9	24	24	30	54	54	60	60	75	75	90	90
效率 Efficiency	80%	80%	70%	70%	70%	60%	60%	60%	60%	50%	50%	50%	50%
長度 Length (L)	33.1	33.1	41.8	41.8	41.8	50.5	50.5	50.5	50.5	59.2	59.2	59.2	59.2
重量 (含油軸承) Weight (g) /Sleeve bearing	147	147	195	195	195	243	243	243	243	291	291	291	291
重量 (滾珠軸承) Weight (g) /Ball bearings	149	149	197	197	197	245	245	245	245	293	293	293	293

Encoder

Driver

- 使用相對溼度：20%~85%RH  
Operating relative humidity
- 使用溫度範圍：-10°C~+60°C  
Operating temperature range

# IG-38PGM

## 01 & 02 TYPE



### 外形尺寸/ Appearance Size

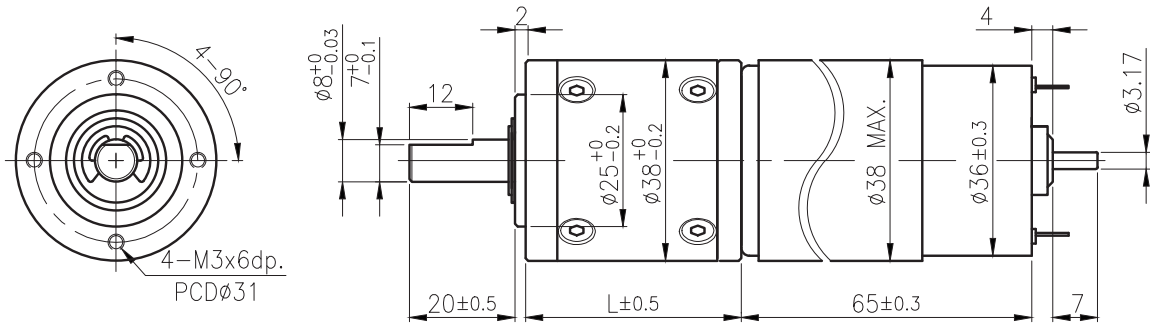

unit:mm

### 齒輪箱馬達轉矩 & 速度/ Gear Motor Torque & Speed

減速比 Reduction ratio	1/5	1/14	1/19	1/27	1/51	1/71	1/100	1/139	1/189	1/264	1/516	1/721				
12V 定格扭力 Rated torque (kgf-cm)	1	2.4	3.3	4.7	7.6	10	15	20	23	25	30	30				
12V 定格轉速 Rated speed (rpm)	1100	420	300	210	110	81	58	41	30	22.5	11.6	8.4				
24V 定格扭力 Rated torque (kgf-cm)	1.1	2.7	3.7	5.2	8.5	12	16	20	25	25	30	30				
24V 定格轉速 Rated speed (rpm)	1050	390	280	200	105	76	55	41	29	22.5	11.6	8.4				
軸心迴轉方向 Rotation direction	CCW															
長度 Length (L)	33.1		41.8				50.5				59.2					

### 馬達單體型式/ Motor Data

定格電壓 Rated volt (V)	定格扭力 Rated torque (gf-cm)	定格轉速 Rated speed (rpm)	定格電流 Rated current (A)	無負荷轉速 No load speed (rpm)	無負荷電流 No load current (A)	定格出力 Rated output (W)	重量 Weight (g)
12	250	5800	≤1.6	6400	≤0.3	14.89	264
24	280	5500	≤0.9	6400	≤0.16	15.81	266

### 馬達單體特性/ Motor Characteristics

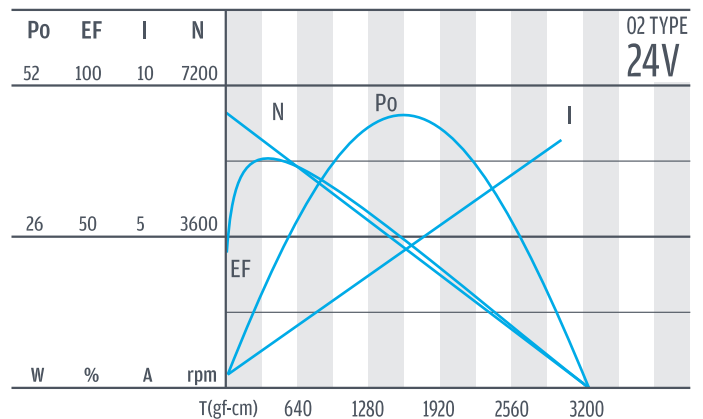
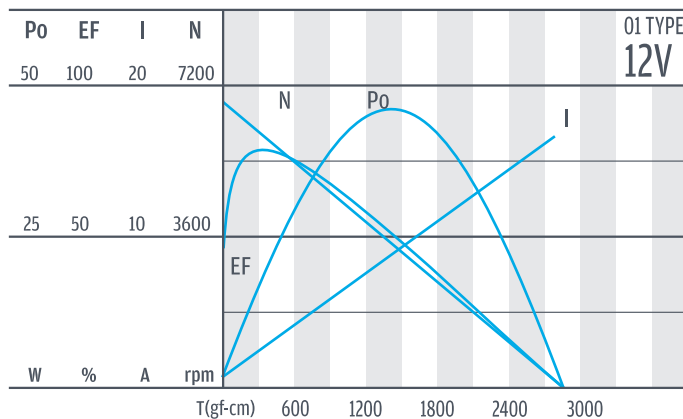

IG

# IG-42



## 外形尺寸 & 馬達齒鉤合尺寸 / Appearance Size & Pinion Assembly Dimension

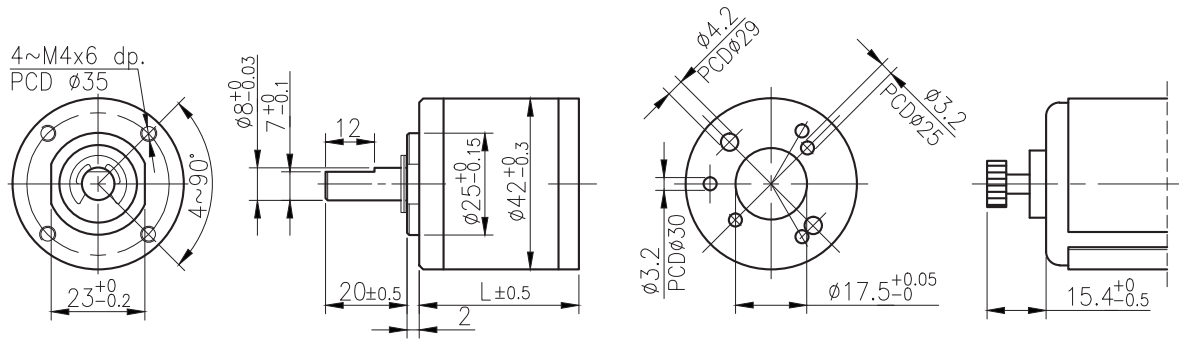

unit:mm

## 產品規格 / Product Specifications

外殼材質 Housing material	輸出軸承型式 Output shaft bearing	徑向負荷 Radial load (10mm from flange)	軸向負荷 Shaft axial load	主軸承受壓入力 Shaft press fit force	徑向間隙 Radial play of shaft	軸向間隙 Thrust play of shaft	背隙 (無負荷時) Backlash, at no-load
金屬 Metal	含油軸承 Sleeve bearing	$\leq 5$ kgf	$\leq 3$ kgf	$\leq 15$ kgf	$\leq 0.08$ mm	$\leq 0.3$ mm	$\leq 3^\circ$
金屬 Metal	滾珠軸承 Ball bearings	$\leq 8$ kgf	$\leq 3$ kgf	$\leq 15$ kgf	$\leq 0.05$ mm	$\leq 0.3$ mm	$\leq 3^\circ$

## 馬達齒輪型式 / Pinion Specifications

模數 Module	齒數 No. of teeth	壓力角 Pressure angle	孔径 (mm) Hole diameter	減速比 Reduction ratio
0.6	12	$20^\circ$	$\phi 3.98$	1/24, 1/144, 1/864
0.6	15	$20^\circ$	$\phi 4.98$	1/720, 1/1062, 1/1470, 1/2500, 1/3000, 1/3600
0.6	18	$20^\circ$	$\phi 4.98$	1/17, 1/61, 1/104, 1/212, 1/624
0.6	24	$20^\circ$	$\phi 4.98$	1/14, 1/49, 1/84, 1/294, 1/504
0.6	20	$20^\circ$	$\phi 4.98$	1/4

## 標準減速比型式 / Gearboxes Specifications

減速比 Reduction ratio	1/4	1/14	1/17	1/24	1/49	1/61	1/84	1/104	1/144	1/212	1/294	1/504	1/624	1/720	1/864	1/1062	1/1470	1/2500	1/3000	1/3600
定格容許扭力 (kgf-cm max.) Rated tolerance torque	3	8	8	8	18	18	18	20	20	25	25	30	30	30	30	30	30	30	30	30
瞬間容許扭力 (kgf-cm) Max momentary tolerance torque	9	24	24	24	54	54	54	60	60	75	75	90	90	90	90	90	90	90	90	90
效率 Efficiency	80%	70%	70%	70%	60%	60%	60%	60%	60%	50%	50%	50%	50%	50%	50%	40%	40%	40%	40%	40%
長度 Length (L)	32.5	39.2	39.2	39.2	45.9	45.9	45.9	45.9	45.9	52.6	52.6	52.6	52.6	52.6	52.6	59.6	59.6	59.6	59.6	59.6
重量 (含油軸承) Weight (g) /Sleeve bearing	141	193	193	193	233	233	233	233	233	283	283	283	283	283	283	328	328	328	328	328
重量 (滾珠軸承) Weight (g) /Ball bearings	139	191	191	191	231	231	231	231	231	281	281	281	281	281	281	326	326	326	326	326

- 使用相對溼度：20%~85%RH  
Operating relative humidity
- 使用溫度範圍：-10°C~+60°C  
Operating temperature range



# IG-42GM

## 01 & 02 TYPE



### 外形尺寸/ Appearance Size

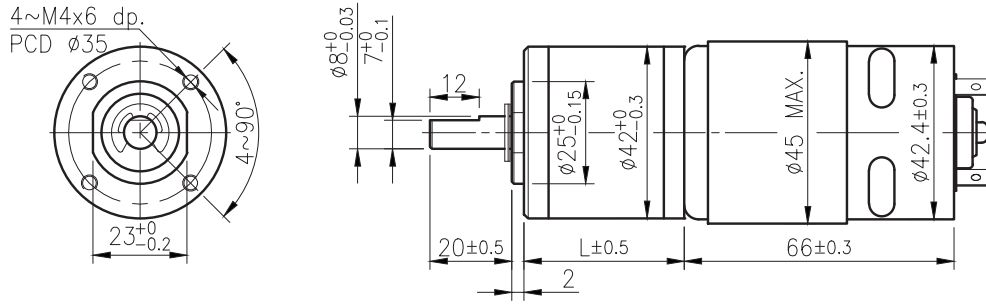

unit:mm

### 齒輪箱馬達轉矩 & 速度/ Gear Motor Torque & Speed

		1/4	1/14	1/17	1/24	1/49	1/61	1/84	1/104	1/144	1/212	1/294	1/504	1/624	1/720	1/864	1/1062	1/1470	1/2500	1/3000	1/3600	
12V	減速比 Reduction ratio																					
	定格扭力 Rated torque (kgf-cm)	2.2	6.5	8	8	18	18	18	20	20	25	25	30	30	30	30	30	30	30	30	30	30
24V	定格轉速 Rated speed (rpm)	1400	405	325	248	120	98	76	63	45	31	22	13.5	10.9	9.5	8	6.5	4.6	2.7	2.3	1.9	1.9
	定格扭力 Rated torque (kgf-cm)	1.8	5.4	6.6	8	16	18	18	20	20	25	25	30	30	30	30	30	30	30	30	30	30
軸心迴轉方向 Rotation direction		CCW																				
長度 Length (L)		32.5	39.2				45.9						52.6						59.6			

### 馬達單體型式/ Motor Data

定格電壓 Rated volt (V)	定格扭力 Rated torque (gf-cm)	定格轉速 Rated speed (rpm)	定格電流 Rated current (A)	無負荷轉速 No load speed (rpm)	無負荷電流 No load current (A)	定格出力 Rated output (W)	重量 Weight (g)
12	700	5700	≤5.5	7000	≤0.9	41.3	360
24	570	5900	≤2.1	7000	≤0.5	34.7	360

### 馬達單體特性/ Motor Characteristics

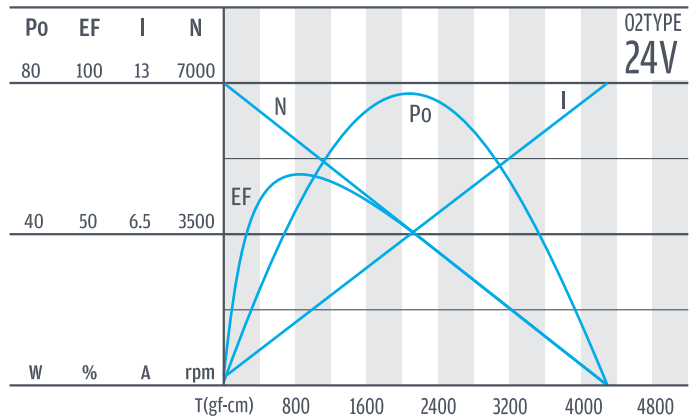
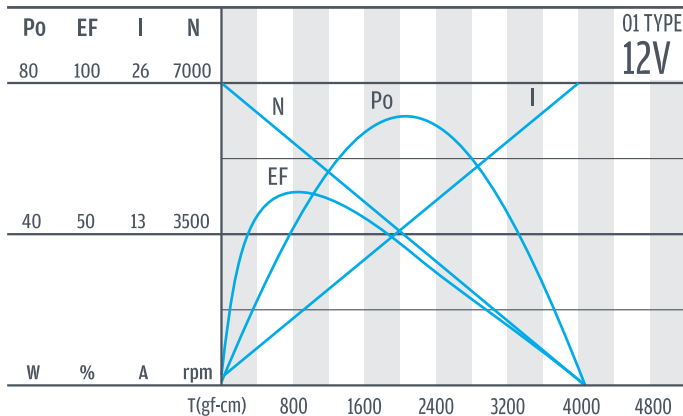

IG

# IG-42GM

## 61 TYPE



Right Angle

### 外形尺寸/ Appearance Size

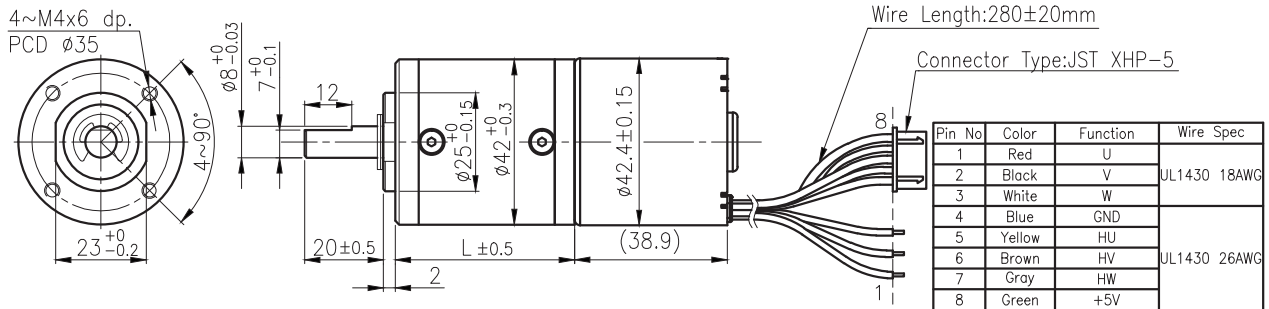

RA



unit:mm

RB

### 齒輪箱馬達轉矩 & 速度/ Gear Motor Torque & Speed

減速比 Reduction ratio	1/4	1/14	1/17	1/24	1/49	1/61	1/84	1/104	1/144	1/212	1/294	1/504	1/624	1/720	1/864	1/1062	1/1470	1/2500	1/3000	1/3600
24V 定格扭力 Rated torque (kgf-cm)	2.2	6.5	8	8	18	18	18	20	20	25	25	30	30	30	30	30	30	30	30	30
定格轉速 Rated speed (rpm)	1590	460	380	310	135	120	95	80	62	42	32	19.5	16	14	11.8	9.6	7	4.1	3.4	2.8
軸心迴轉方向 Rotation direction	CW																			
長度 Length (L)	32.5	39.2	45.9				52.6				59.6									

WG

### 馬達單體型式/ Motor Data

定格電壓 Rated volt (V)	定格扭力 Rated torque (gf-cm)	定格轉速 Rated speed (rpm)	定格電流 Rated current (A)	無負荷轉速 No load speed (rpm)	無負荷電流 No load current (A)	定格出力 Rated output (W)	重量 Weight (g)
24	400	7930	≤19	11000	≤0.4	30	196

PG

### 馬達單體特性/ Motor Characteristics

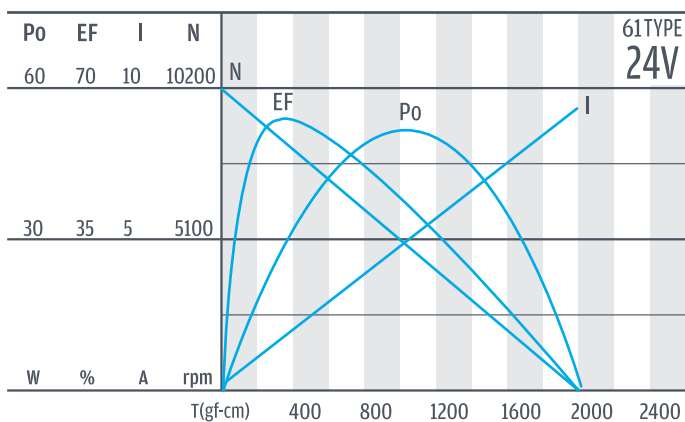

Encoder

Driver

# IG-42GM

## 62 & 63 TYPE



外形尺寸/ Appearance Size

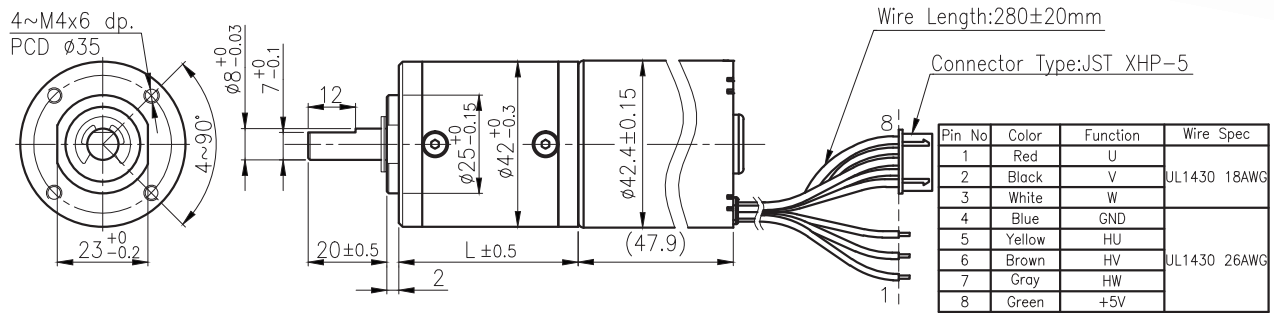

unit:mm

齒輪箱馬達轉矩 & 速度/ Gear Motor Torque & Speed

減速比 Reduction ratio	1/4	1/14	1/17	1/24	1/49	1/61	1/84	1/104	1/144	1/212	1/294	1/504	1/624	1/720	1/864	1/1062	1/1470	1/2500	1/3000	1/3600
12V 定格扭力 Rated torque(kgf-cm)	1.5	4.7	5.8	8	14	17.5	18	20	20	25	25	30	30	30	30	30	30	30	30	30
12V 定格轉速 Rated speed (rpm)	900	255	205	150	73	55	45	35	25	18	14	8	6.5	5.5	5	4	2.5	1.7	1.4	1.2
24V 定格扭力 Rated torque(kgf-cm)	2.2	6.5	8	8	18	18	18	20	20	25	25	30	30	30	30	30	30	30	30	30
24V 定格轉速 Rated speed (rpm)	1270	370	300	235	110	90	72	60	45	30	23	13.5	11	9.5	8.1	6.6	4.8	4.1	3.4	2
軸心迴轉方向 Rotation direction	CW/CCW																			
長度 Length (L)	32.5		39.2		45.9				52.6				59.6							

馬達單體型式/ Motor Data

定格電壓 Rated volt (V)	定格扭力 Rated torque (kgf-cm)	定格轉速 Rated speed (rpm)	定格電流 Rated current (A)	無負荷轉速 No load speed (rpm)	無負荷電流 No load current (A)	定格出力 Rated output (W)	重量 Weight (g)
12	480	3600	≤ 2.2	4500	≤ 0.45	17	265
24	490	5600	≤ 1.83	7200	≤ 0.3	27	265

馬達單體特性/ Motor Characteristics

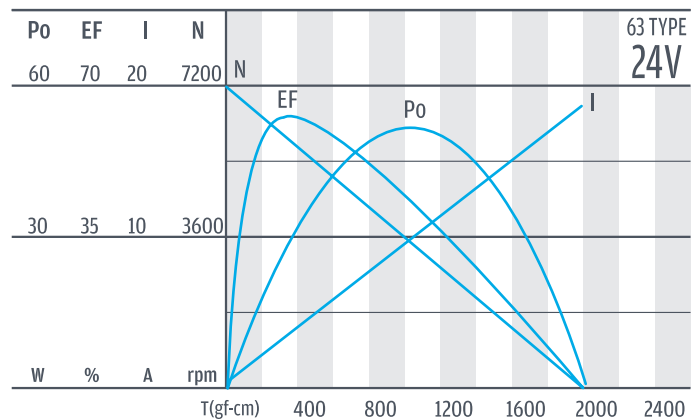
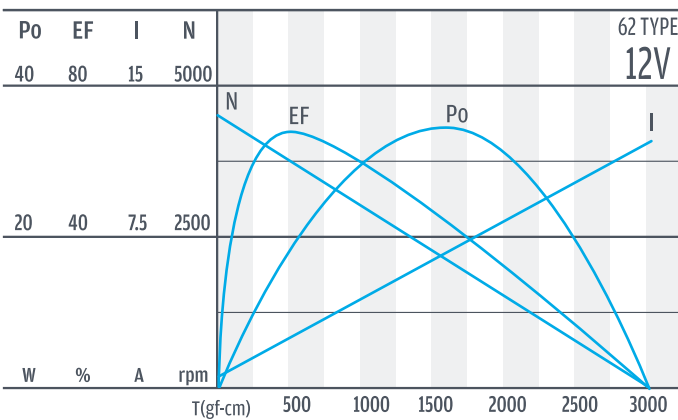

IG

# IG-42GM

## 65 TYPE



Right Angle

### 外形尺寸/ Appearance Size

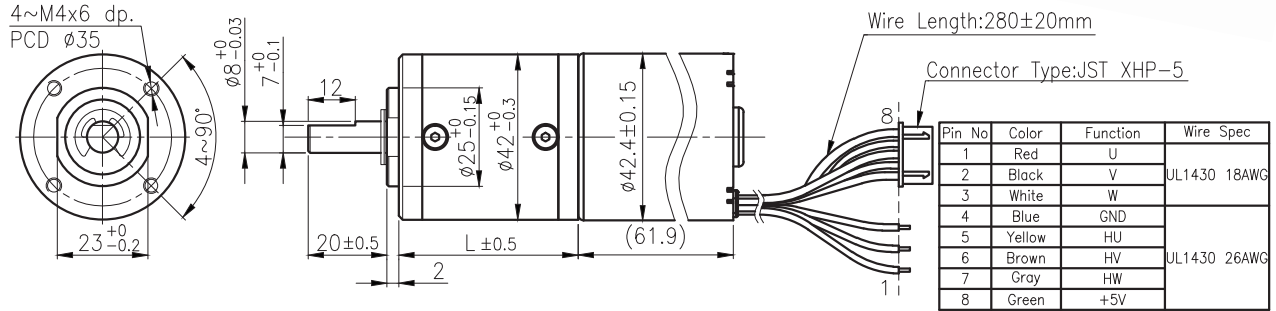

RA



unit:mm

RB

### 齒輪箱馬達轉矩 & 速度/ Gear Motor Torque & Speed

減速比 Reduction ratio	1/4	1/14	1/17	1/24	1/49	1/61	1/84	1/104	1/144	1/212	1/294	1/504	1/624	1/720	1/864	1/1062	1/1470	1/2500	1/3000	1/3600
24V 定格扭力 Rated torque (kgf-cm)	2.7	8	8	8	18	18	18	20	20	25	25	30	30	30	30	30	30	30	30	30
24V 定格轉速 Rated speed (rpm)	1125	325	270	200	95	75	55	45	35	24	17	10	8.4	7.3	6	5	3.5	2.1	1.7	1.4
軸心迴轉方向 Rotation direction	CW/CCW																			
長度 Length (L)	32.5		39.2		45.9				52.6				59.6							

WG

### 馬達單體型式/ Motor Data

定格電壓 Rated volt (V)	定格扭力 Rated torque (kgf-cm)	定格轉速 Rated speed (rpm)	定格電流 Rated current (A)	無負荷轉速 No load speed (rpm)	無負荷電流 No load current (A)	定格出力 Rated output (W)	重量 Weight (g)
24	870	4500	≤ 2.3	5400	≤ 0.4	40	365

PG

### 馬達單體特性/ Motor Characteristics

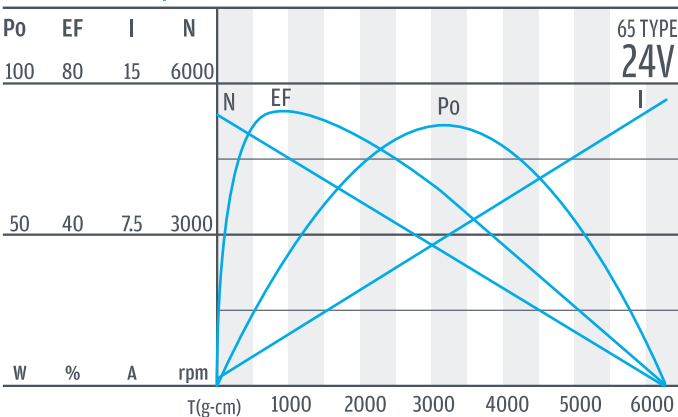

Encoder

Driver

# IG-42C



## 外形尺寸 & 馬達齒鉤合尺寸 / Appearance Size & Pinion Assembly Dimension

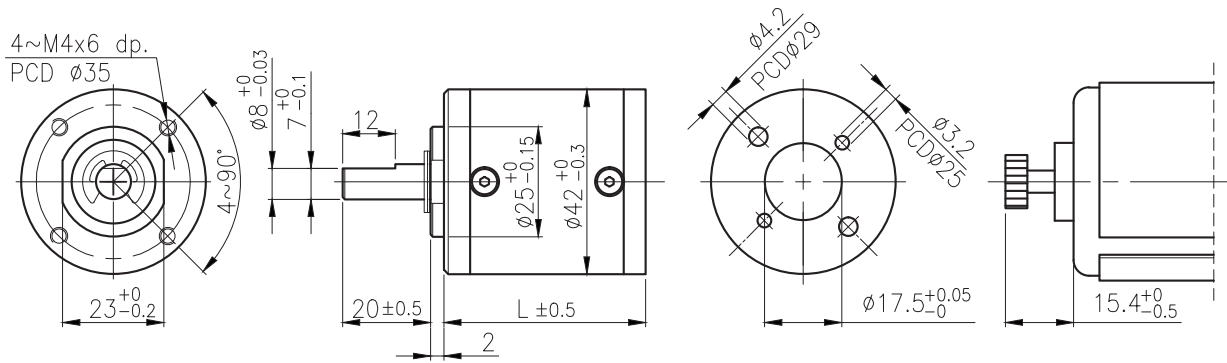

unit:mm

## 產品規格 / Product Specifications

外殼材質 Housing material	輸出軸承型式 Output shaft bearing	徑向負荷 Radial load (10mm from flange)	軸向負荷 Shaft axial load	主軸承受壓力 Shaft press fit force	徑向間隙 Radial play of shaft	軸向間隙 Thrust play of shaft	背隙 (無負荷時) Backlash, at no-load
金屬 Metal	含油軸承 Sleeve bearing	≤ 5 kgf	≤ 3 kgf	≤ 15 kgf	≤ 0.08 mm	≤ 0.3 mm	≤ 3°
金屬 Metal	滾珠軸承 Ball bearings	≤ 8 kgf	≤ 3 kgf	≤ 15kgf	≤ 0.05 mm	≤ 0.3 mm	≤ 3°

## 馬達齒輪型式 / Pinion Specifications

模數 Module	齒數 No. of teeth	壓力角 Pressure angle	孔徑 (mm) Hole diameter	減速比 Reduction ratio
0.6	12	20°	ø3.98	1/24, 1/144, 1/864
0.6	15	20°	ø4.98	1/720, 1/1062, 1/1470, 1/2500, 1/3000, 1/3600
0.6	18	20°	ø4.98	1/17, 1/61, 1/104, 1/212, 1/624
0.6	24	20°	ø4.98	1/14, 1/49, 1/84, 1/294, 1/504
0.6	20	20°	ø4.98	1/4

## 標準減速比型式 / Gearboxes Specifications

減速比 Reduction ratio	1/4	1/14	1/17	1/24	1/49	1/61	1/84	1/104	1/144	1/212	1/294	1/504	1/624	1/720	1/864	1/1062	1/1470	1/2500	1/3000	1/3600
定格容許扭力 (kgf-cm max.) Rated tolerance torque	3	8	8	8	18	18	18	20	20	25	25	30	30	30	30	30	30	30	30	30
瞬間容許扭力 (kgf-cm) Max momentary tolerance torque	9	24	24	24	54	54	54	60	60	75	75	90	90	90	90	90	90	90	90	90
效率 Efficiency	80%	70%	70%	70%	60%	60%	60%	60%	60%	50%	50%	50%	50%	50%	50%	40%	40%	40%	40%	40%
長度 Length (L)	32.5	39.2	39.2	39.2	45.9	45.9	45.9	45.9	45.9	52.6	52.6	52.6	52.6	52.6	52.6	59.6	59.6	59.6	59.6	59.6
重量 (含油軸承) Weight (g) /Sleeve bearing	141	193	193	193	233	233	233	233	233	283	283	283	283	283	283	328	328	328	328	328
重量 (滾珠軸承) Weight (g) /Ball bearings	139	191	191	191	231	231	231	231	231	281	281	281	281	281	281	326	326	326	326	326

- 使用相對溼度：20%~85%RH  
Operating relative humidity
- 使用溫度範圍：-10°C~+60°C  
Operating temperature range

IG  
Right Angle  
RA  
RB  
WG  
PG  
Encoder  
Driver

IG

# IG-42CGM

## 01 & 02 TYPE



Right Angle

### 外形尺寸/ Appearance Size

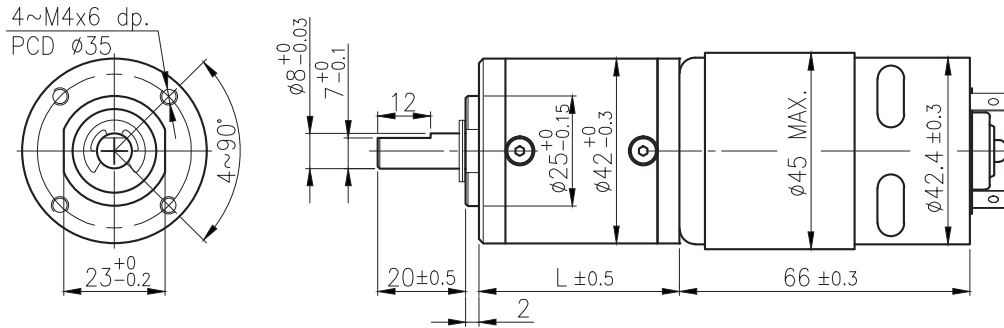

unit:mm

RA

RB

### 齒輪箱馬達轉矩 & 速度/ Gear Motor Torque & Speed

	減速比 Reduction ratio	1/4	1/14	1/17	1/24	1/49	1/61	1/84	1/104	1/144	1/212	1/294	1/504	1/624	1/720	1/864	1/1062	1/1470	1/2500	1/3000	1/3600
12V	定格扭力 Rated torque (kgf-cm)	2.2	6.5	8	8	18	18	18	20	20	25	25	30	30	30	30	30	30	30	30	30
	定格轉速 Rated speed (rpm)	1400	405	325	248	120	98	76	63	45	31	22	13.5	10.9	9.5	8	6.5	4.6	2.7	2.3	1.9
24V	定格扭力 Rated torque (kgf-cm)	1.8	5.4	6.6	8	16	18	18	20	20	25	25	30	30	30	30	30	30	30	30	30
	定格轉速 Rated speed (rpm)	1445	420	340	246	122	102	77.5	63	47	31	21.8	13.5	10.9	9.5	8	6.5	4.6	2.7	2.3	1.9
	軸心迴轉方向 Rotation direction	CCW																			
	長度 Length (L)	32.5			39.2			45.9			52.6			59.6							

WG

PG

### 馬達單體型式/ Motor Data

定格電壓 Rated volt (V)	定格扭力 Rated torque (gf-cm)	定格轉速 Rated speed (rpm)	定格電流 Rated current (A)	無負荷轉速 No load speed (rpm)	無負荷電流 No load current (A)	定格出力 Rated output (W)	重量 Weight (g)
12	700	5700	≤5.5	7000	≤0.9	41.3	360
24	570	5900	≤2.1	7000	≤0.5	34.7	360

### 馬達單體特性/ Motor Characteristics

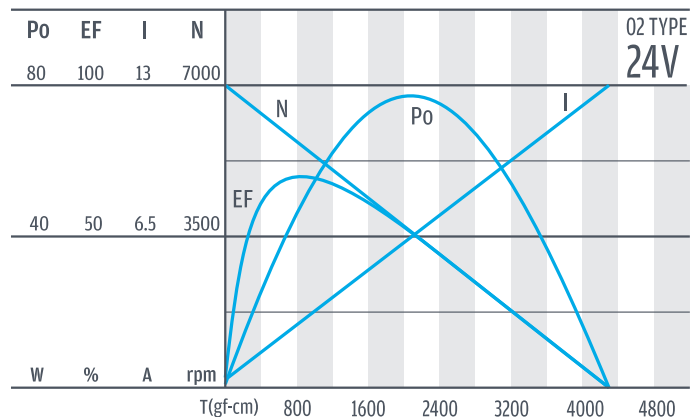
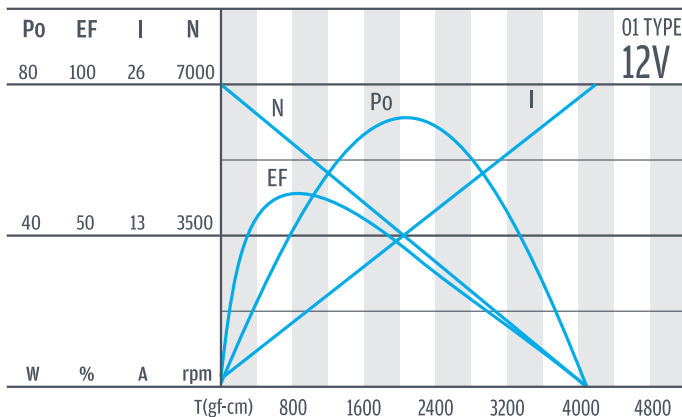

Encoder

Driver

# IG-42CGM

## 03 & 04 TYPE



### 外形尺寸/ Appearance Size

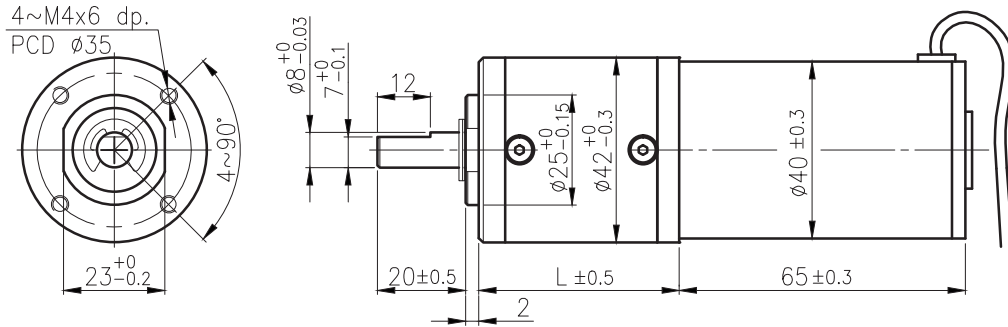

unit:mm

### 齒輪箱馬達轉矩 & 速度/ Gear Motor Torque & Speed

	減速比 Reduction ratio	1/4	1/14	1/17	1/24	1/49	1/61	1/84	1/104	1/144	1/212	1/294	1/504	1/624	1/720	1/864	1/1062	1/1470	1/2500	1/3000	1/3600
12V	定格扭力 Rated torque (kgf-cm)	1.3	4	5	7	12	15	18	20	20	25	25	30	30	30	30	30	30	30	30	30
	定格轉速 Rated speed (rpm)	930	265	210	150	76	61	45	37	27	18.5	14	8.3	6.9	5.9	4.9	4	2.8	1.7	1.4	1.2
24V	定格扭力 Rated torque (kgf-cm)	1	3	4	5.5	10	12	17	20	20	25	25	30	30	30	30	30	30	30	30	30
	定格轉速 Rated speed (rpm)	945	270	215	155	76	62	45	36	27	18.5	14	8.3	6.9	5.9	4.9	4	2.8	1.7	1.4	1.2
軸心迴轉方向 Rotation direction		CW																			
長度 Length (L)		32.5	39.2			45.9			52.6			59.6									

### 馬達單體型式/ Motor Data

定格電壓 Rated volt (V)	定格扭力 Rated torque (gf-cm)	定格轉速 Rated speed (rpm)	定格電流 Rated current (A)	無負荷轉速 No load speed (rpm)	無負荷電流 No load current (A)	定格出力 Rated output (W)	重量 Weight (g)
12	430	3750	≤2.0	4500	≤0.5	16.56	310
24	350	3800	≤0.82	4500	≤0.22	13.65	310

### 馬達單體特性/ Motor Characteristics

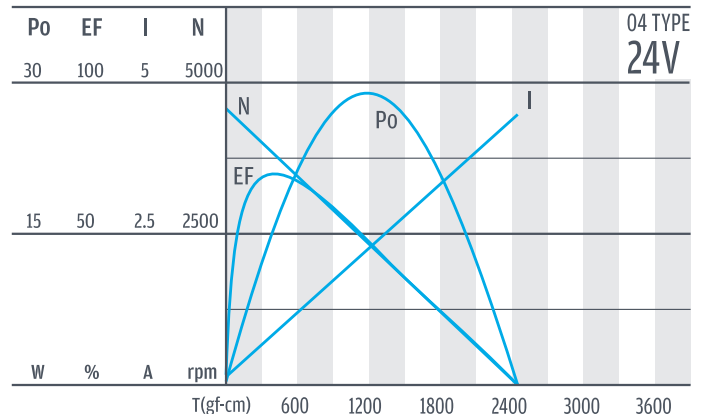
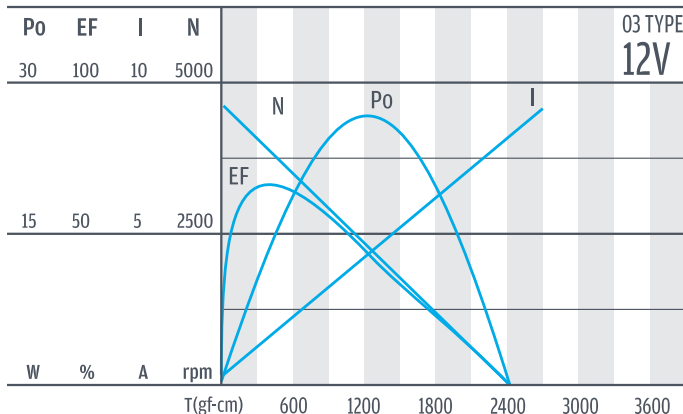



IG

# IG-42H



Right Angle

## 外形尺寸 & 馬達齒鉚合尺寸 / Appearance Size & Pinion Assembly Dimension

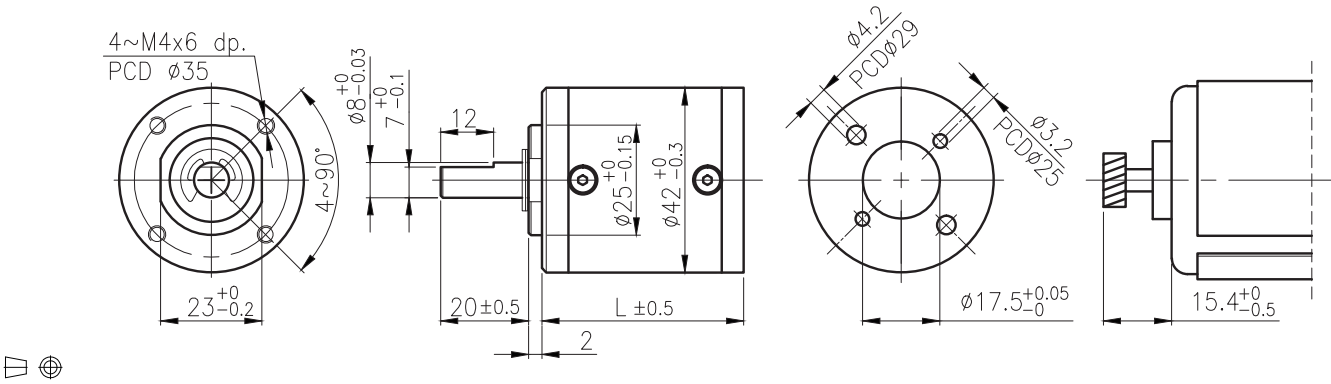

unit:mm

RA

RB

## 產品規格 / Product Specifications

外殼材質 Housing material	輸出軸承型式 Output shaft bearing	徑向負荷 Radial load (10mm from flange)	軸向負荷 Shaft axial load	主軸承受壓入力 Shaft press fit force	徑向間隙 Radial play of shaft	軸向間隙 Thrust play of shaft	背隙 (無負荷時) Backlash, at no-load
金屬 Metal	含油軸承 Sleeve bearing	≤ 5 kgf	≤ 3 kgf	≤ 15 kgf	≤ 0.08 mm	≤ 0.3 mm	≤ 3'
金屬 Metal	滾珠軸承 Ball bearings	≤ 8 kgf	≤ 3 kgf	≤ 15 kgf	≤ 0.05 mm	≤ 0.3 mm	≤ 3'

WG

## 馬達齒輪型式 / Pinion Specifications

模數 Module	齒數 No. of teeth	螺旋角 Helix angle	壓力角 Pressure angle	孔徑 (mm) Hole diameter	減速比 Reduction ratio
0.6	9	18° (左, left)	20°	ø3.15	1/25
0.6	12	18° (左, left)	20°	ø3.98	1/20, 1/100, 1/120, 1/500, 1/600, 1/720 1/1062, 1/2500, 1/3000, 1/3600
0.6	15	18° (左, left)	20°	ø4.98	1/17, 1/84, 1/294, 1/1470
0.6	18	18° (左, left)	20°	ø4.98	1/15, 1/51, 1/64, 1/180, 1/222

PG

## 標準減速比型式 / Gearboxes Specifications

減速比 Reduction ratio	1/15	1/17	1/20	1/25	1/51	1/64	1/84	1/100	1/120	1/180	1/222	1/294	1/500	1/600	1/720	1/1062	1/1470	1/2500	1/3000	1/3600
定格容許扭力 (kgf-cm max.) Rated tolerance torque	8	8	8	8	18	18	18	20	20	25	25	25	30	30	30	30	30	30	30	30
瞬間容許扭力 (kgf-cm) Max momentary tolerance torque	24	24	24	24	54	54	54	60	60	75	75	75	90	90	90	90	90	90	90	90
效率 Efficiency	70%	70%	70%	70%	60%	60%	60%	60%	60%	50%	50%	50%	50%	50%	50%	40%	40%	40%	40%	40%
長度 Length (L)	39.2	39.2	39.2	39.2	45.9	45.9	45.9	45.9	45.9	52.6	52.6	52.6	52.6	52.6	52.6	59.6	59.6	59.6	59.6	59.6
重量 (含油軸承) Weight (g) / Sleeve bearing	193	193	193	193	233	233	233	233	233	283	283	283	283	283	283	328	328	328	328	328
重量 (滾珠軸承) Weight (g) / Ball bearings	191	191	191	191	231	231	231	231	231	281	281	281	281	281	281	326	326	326	326	326

Encoder

Driver

- 使用相對溼度：20%~85%RH  
Operating relative humidity
- 使用溫度範圍：-10°C~+60°C  
Operating temperature range

# IG-42HGM

## 41 & 42 TYPE



### 外形尺寸 / Appearance Size

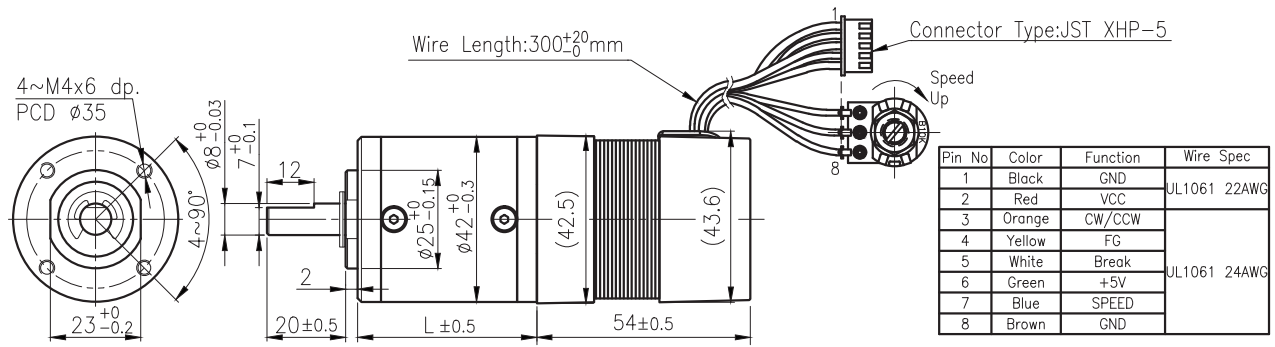

unit:mm

### 齒輪箱馬達轉矩 & 速度 / Gear Motor Torque & Speed

減速比 Reduction ratio	1/15	1/17	1/20	1/25	1/51	1/64	1/84	1/100	1/120	1/180	1/222	1/294	1/500	1/600	1/720	1/1062	1/1470	1/2500	1/3000	1/3600	
12V 定格扭力 Rated torque (kgf-cm)	2.6	3.0	3.5	4.5	7.5	9.5	12.5	15	18	22.5	27.8	30	30	30	30	30	30	30	30	30	
12V 定格轉速 Rated speed (rpm)	270	230	200	155	80	65	50	40	33	22	18	14.5	9.1	7.8	6.6	4.5	3.3	2.0	1.6	1.4	
24V 定格扭力 Rated torque (kgf-cm)	3.9	4.5	5.2	6.4	11.5	14.5	18.6	22	26.6	28	30	30	30	30	30	30	30	30	30	30	
24V 定格轉速 Rated speed (rpm)	280	245	210	170	80	65	50	42	35	24	20	15.5	9.6	8.0	6.8	4.6	3.4	2.0	1.7	1.4	
長度 Length (L)	39.2			45.9			52.6			59.6											

### 馬達單體型式 / Motor Data

定格電壓 Rated volt (V)	定格扭力 Rated torque (gf-cm)	定格轉速 Rated speed (rpm)	定格電流 Rated current (A)	無負荷轉速 No load speed (rpm)	無負荷電流 No load current (A)	定格出力 Rated output (W)	重量 Weight (g)
12	250	4000	≤ 1.6	5000	≤ 0.3	10.5	250
24	370	4200	≤ 1.1	5000	≤ 0.25	16.2	250

### 馬達單體特性 / Motor Characteristics

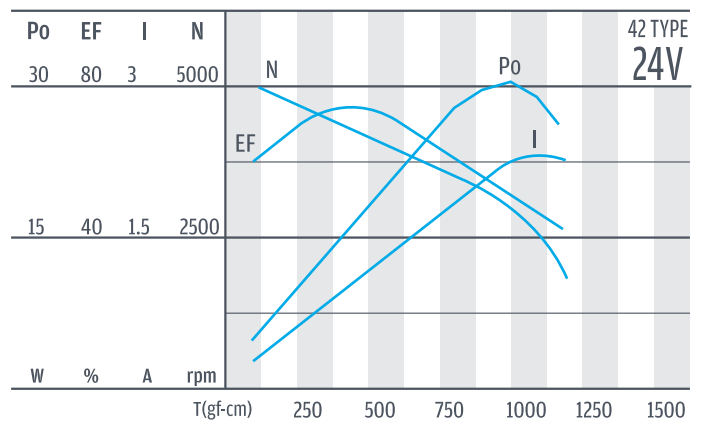
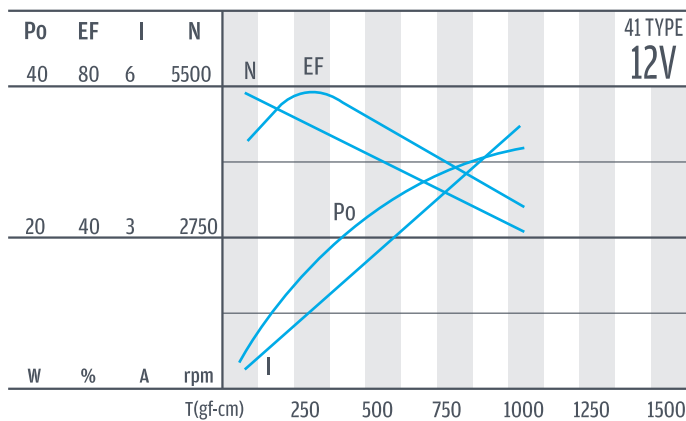

IG

# IG-43



Right Angle

## 外形尺寸 & 馬達齒鉤尺寸 / Appearance Size & Pinion Assembly Dimension

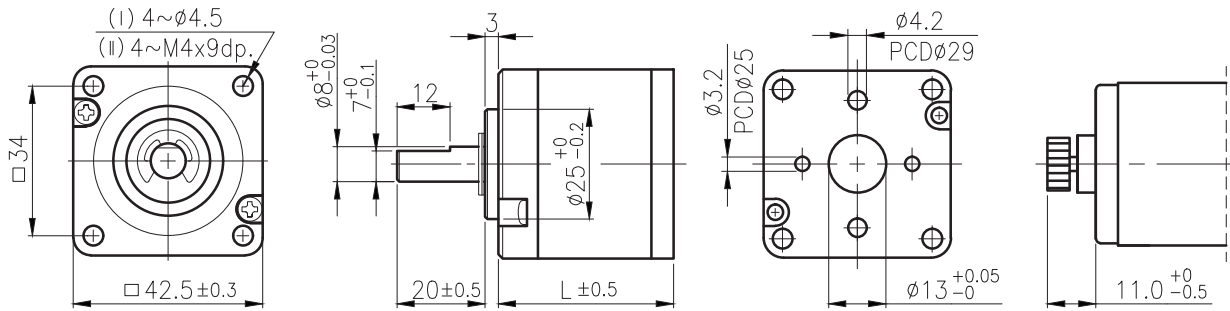

unit:mm

RA

## 產品規格/ Product Specifications

外殼材質 Housing material	輸出軸承型式 Output shaft bearing	徑向負荷 Radial load (10mm from flange)	軸向負荷 Shaft axial load	主軸承受壓入力 Shaft press fit force	徑向間隙 Radial play of shaft	軸向間隙 Thrust play of shaft	背隙 (無負荷時) Backlash, at no-load
粉末金屬 Powder Metal	滾珠軸承 Ball bearings	≤ 8 kgf	≤ 3 kgf	≤ 15kgf	≤ 0.05 mm	≤ 0.3 mm	≤ 3°

RB

## 馬達齒輪型式/ Pinion Specifications

模數 Module	齒數 No. of teeth	壓力角 Pressure angle	孔徑 (mm) Hole diameter	減速比 Reduction ratio
0.6	12	20°	∅3.16, ∅3.98	1/24, 1/84, 1/104, 1/144, 1/294, 1/504, 1/624, 1/720, 1/864
0.6	18	20°	∅3.16, ∅3.98	1/17, 1/61, 1/212
0.6	24	20°	∅3.16, ∅3.98	1/14, 1/49
0.6	20	20°	∅3.16, ∅3.98	1/4

WG

## 標準減速比型式/ Gearboxes Specifications

減速比 Reduction ratio	1/4	1/14	1/17	1/24	1/49	1/61	1/84	1/104	1/144	1/212	1/294	1/504	1/624	1/720	1/864
定格容許扭力 (kgf-cm max.) Rated tolerance torque	4	8	8	8	15	15	15	20	20	25	25	30	30	30	30
瞬間容許扭力 (kgf-cm) Max momentary tolerance torque	12	24	24	24	45	45	45	60	60	75	75	90	90	90	90
效率 Efficiency	80%	70%	70%	70%	60%	60%	60%	60%	60%	50%	50%	50%	50%	50%	50%
長度 (L) Length (L)	26.15	32.95	32.95	32.95	39.75	39.75	39.75	39.75	39.75	46.45	46.45	46.45	46.45	46.45	46.45
重量 (滾珠軸承) Weight (g) /Ball bearings	190	250	250	250	305	305	305	305	305	360	360	360	360	360	360

PG

Encoder

Driver

- 使用相對溼度：20%~85%RH  
Operating relative humidity
- 使用溫度範圍：-10°C~+60°C  
Operating temperature range

# IG-43GM

## 01 & 02 TYPE



### 外形尺寸/ Appearance Size

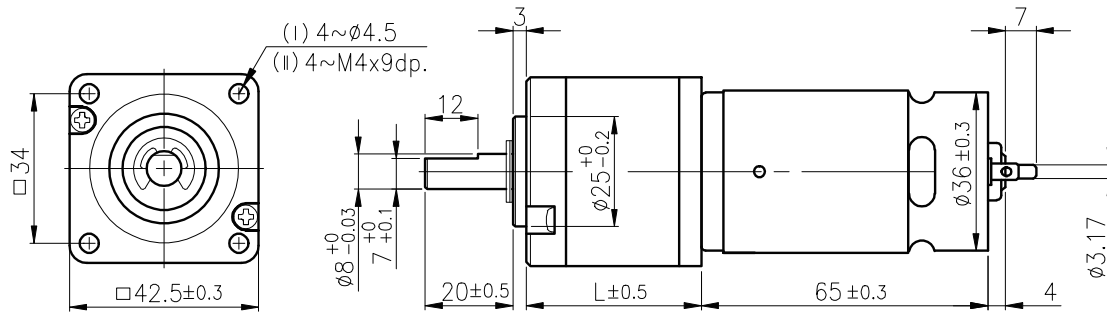

unit:mm

### 齒輪箱馬達轉矩 & 速度/ Gear Motor Torque & Speed

		1/4	1/14	1/17	1/24	1/49	1/61	1/84	1/104	1/144	1/212	1/294	1/504	1/624	1/720	1/864
12V	減速比 Reduction ratio	1/4	1/14	1/17	1/24	1/49	1/61	1/84	1/104	1/144	1/212	1/294	1/504	1/624	1/720	1/864
	定額扭力 Rated torque (kgf-cm)	1	3	3.6	5.2	9.2	11	15	19	20	25	25	30	30	30	30
24V	定額轉速 Rated speed (rpm)	1250	363	293	212	103	83.5	60.5	49	38	25.4	18.9	11.2	8.8	8	6.5
	定額扭力 Rated torque (kgf-cm)	0.9	2.6	3.1	4.5	8	10	14	17	20	25	25	30	30	30	30
軸心迴轉方向 Rotation direction		CCW														
長度 Length (L)		26.15	32.95					39.75						46.45		

### 馬達單體型式/ Motor Data

定額電壓 Rated volt (V)	定額扭力 Rated torque (gf-cm)	定額轉速 Rated speed (rpm)	定額電流 Rated current (A)	無負荷轉速 No load speed (rpm)	無負荷電流 No load current (A)	定額出力 Rated output (W)	重量 Weight (g)
12	320	5090	≤2.1	6000	≤0.35	17.09	266
24	280	5250	≤0.9	6000	≤0.17	15.56	266

### 馬達單體特性/ Motor Characteristics

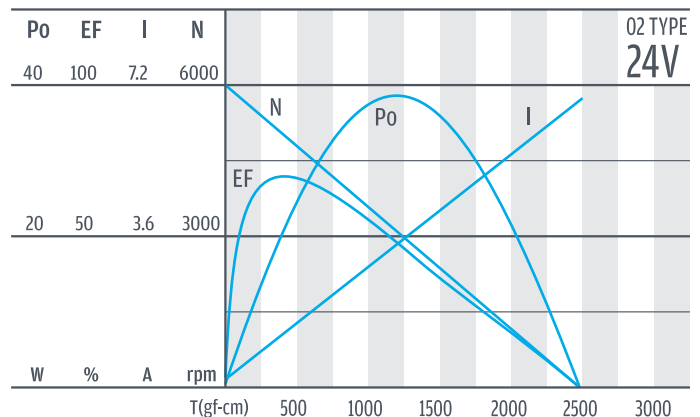
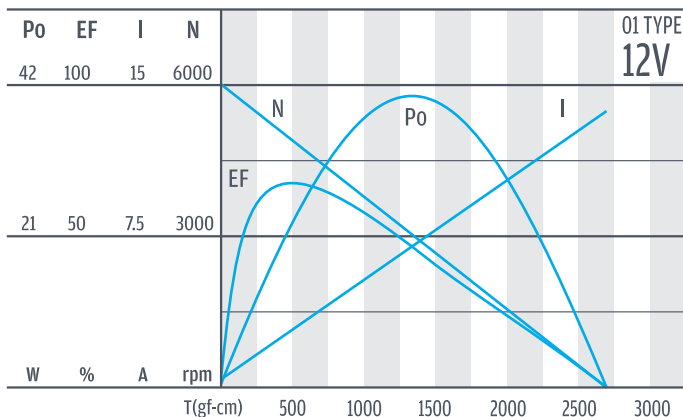

IG

# IG-52



Right Angle

## 外形尺寸 & 馬達齒鉤尺寸 / Appearance Size & Pinion Assembly Dimension

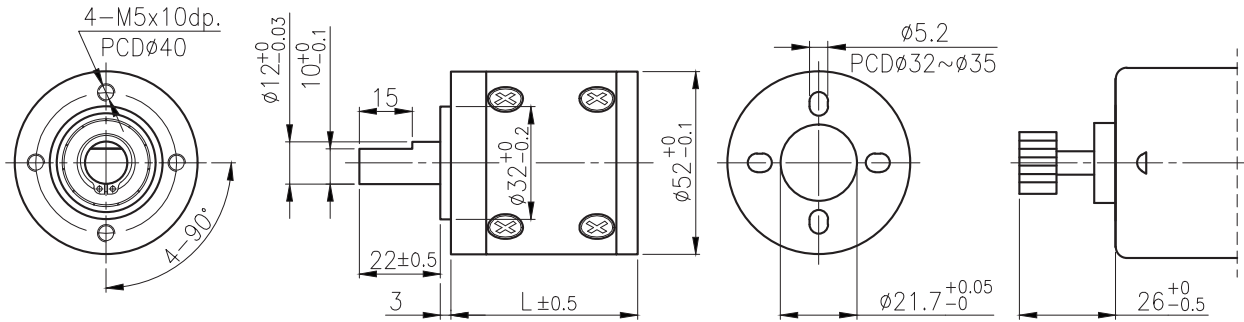

unit:mm

RA

## 產品規格 / Product Specifications

外殼材質 Housing material	輸出軸承型式 Output shaft bearing	徑向負荷 Radial load (10mm from flange)	軸向負荷 Shaft axial load	主軸承受壓力 Shaft press fit force	徑向間隙 Radial play of shaft	軸向間隙 Thrust play of shaft	背隙 (無負荷時) Backlash, at no-load
金屬 Metal	滾珠軸承 Ball bearings	$\leq 20$ kgf	$\leq 10$ kgf	$\leq 30$ kgf	$\leq 0.04$ mm	$\leq 0.3$ mm	$\leq 3^\circ$

RB

## 馬達齒輪型式 / Pinion Specifications

模數 Module	齒數 No. of teeth	壓力角 Pressure angle	孔徑 (mm) Hole diameter	減速比 Reduction ratio
1.0	8	20°	$\phi 3.98$	1/21, 1/26, 1/126, 1/756, 1/936
1.0	12	20°	$\phi 5.98, \phi 6.34$	1/4, 1/15, 1/19, 1/53, 1/66, 1/81, 1/113, 1/230 1/285, 1/353, 1/488, 1/546, 1/676
1.0	16	20°	$\phi 5.98, \phi 6.34$	1/3, 1/12, 1/43, 1/150
1.0	14	20°	$\phi 5.98, \phi 6.34$	1/100

WG

## 標準減速比型式 / Gearboxes Specifications

減速比 Reduction ratio	1/3	1/4	1/12	1/15	1/19	1/21	1/26	1/43	1/53	1/66	1/81	1/100	1/113	1/126	1/150	1/230	1/285	1/353	1/488	1/546	1/676	1/756	1/936
定格容許扭力 (kgf-cm max.) Rated tolerance torque	10	10	30	30	50	50	50	100	100	100	100	100	100	100	100	100	100	100	100	100	100	100	100
瞬間容許扭力 (kgf-cm) Max momentary tolerance torque	30	30	90	90	150	150	150	300	300	300	300	300	300	300	300	300	300	300	300	300	300	300	300
效率 Efficiency	80%	80%	70%	70%	70%	70%	70%	60%	60%	60%	60%	60%	60%	60%	50%	50%	50%	50%	50%	50%	50%	50%	50%
長度 Length (L)	53	53	68.5	68.5	68.5	68.5	68.5	84	84	84	84	84	84	84	99.5	99.5	99.5	99.5	99.5	99.5	99.5	99.5	99.5
重量 (滾珠軸承) Weight (g) / Ball bearings	475	475	660	660	660	660	660	850	850	850	850	850	850	850	1020	1020	1020	1020	1020	1020	1020	1020	1020

Encoder

Driver

- 使用相對溼度：20%~85%RH  
Operating relative humidity
- 使用溫度範圍：-10°C~+60°C  
Operating temperature range

# IG-52GM

## 01 & 02 TYPE



### 外形尺寸/ Appearance Size

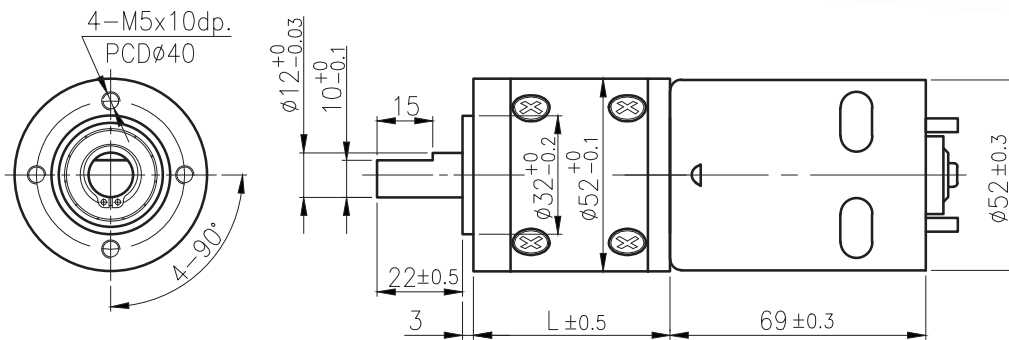

unit:mm

### 齒輪箱馬達轉矩 & 速度/ Gear Motor Torque & Speed

		減速比 Reduction ratio	1/3	1/4	1/12	1/15	1/19	1/43	1/53	1/66	1/81	1/100	1/113	1/150	1/230	1/285	1/353	1/488	1/546	1/676	
12V	定格扭力 Rated torque (kgf-cm)	2.1	2.6	6.5	8.1	10	20.1	24.4	30.2	37.4	46.1	51.8	57.5	88.2	100	100	100	100	100	100	
	定格轉速 Rated speed (rpm)	1445	1167	412	333	269	115	95	76	62	50	44	33	21	18	15	11.3	10	8.2		
24V	定格扭力 Rated torque (kgf-cm)	2.2	2.8	6.9	8.6	10.7	21.4	25.9	32.1	39.7	49	55	61.1	93.7	100	100	100	100	100	100	
	定格轉速 Rated speed (rpm)	1423	1149	406	328	265	113	93	75	61	49	44	33	21	17.9	14.7	10.9	9.8	8		
軸心迴轉方向 Rotation direction		CW																			
長度 Length (L)		53			68.5				84								99.5				

### 馬達單體型式/ Motor Data

定格電壓 Rated volt (V)	定格扭力 Rated torque (gf-cm)	定格轉速 Rated speed (rpm)	定格電流 Rated current (A)	無負荷轉速 No load speed (rpm)	無負荷電流 No load current(A)	定格出力 Rated output (W)	重量 Weight (g)
12	767	5058	≤5.8	6000	≤1.55	39.8	480
24	815	4983	≤3.6	6000	≤0.6	41.7	480

### 馬達單體特性/ Motor Characteristics

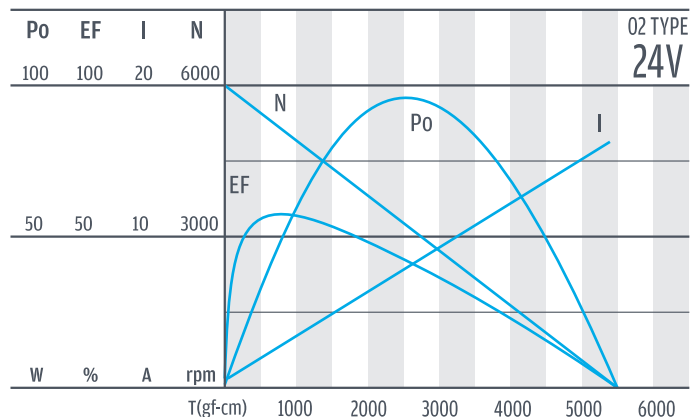
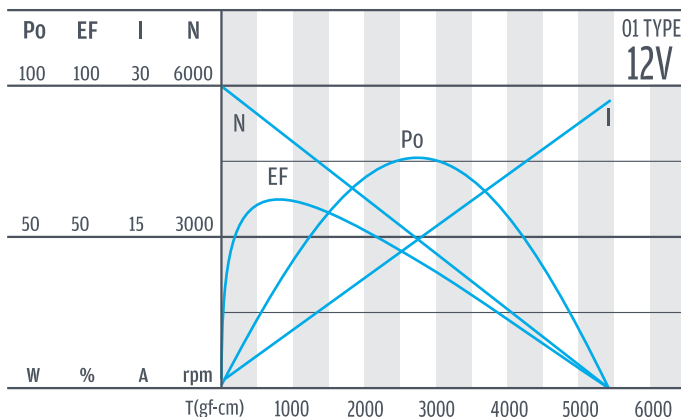

IG

# IG-52GM

## 03 & 04 TYPE



Right Angle

### 外形尺寸/ Appearance Size

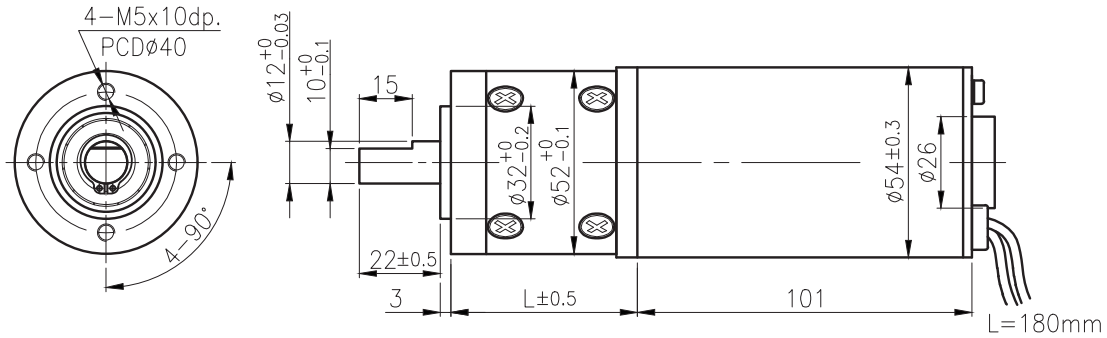

unit:mm

RA



RB

### 齒輪箱馬達轉矩 & 速度/ Gear Motor Torque & Speed

	減速比 Reduction ratio	1/3	1/4	1/12	1/15	1/19	1/26	1/43	1/53	1/66	1/81	1/100	1/113	1/150	1/230	1/285	1/353	1/488	1/546	1/676	1/936
12V	定格扭力 Rated torque (kgf-cm)	2.5	3.1	7.7	9.5	11.8	16	23	28	35	44	54	60	67	100	100	100	100	100	100	100
	定格轉速 Rated speed (rpm)	1030	835	295	238	192	139	84	68	55	44	36	32	24	15.5	12.8	10.4	7.6	6.7	5.6	4
24V	定格扭力 Rated torque (kgf-cm)	3.6	4.5	11	13.5	17	23	33	41	51	62	78	88	97	100	100	100	100	100	100	100
	定格轉速 Rated speed (rpm)	1000	815	285	230	185	136	82	67	54	44	35	31	23.5	15.6	12.9	10.5	7.7	6.8	5.7	4.1
軸心迴轉方向 Rotation direction		CW																			
長度 Length (L)		53			68.5				84				99.5								

WG

PG

### 馬達單體型式/ Motor Data

定格電壓 Rated volt (V)	定格扭力 Rated torque (gf-cm)	定格轉速 Rated speed (rpm)	定格電流 Rated current (A)	無負荷轉速 No load speed (rpm)	無負荷電流 No load current (A)	定格出力 Rated output (W)	重量 Weight (g)
12	900	3620	≤4.1	4000	≤1.2	33.5	920
24	1300	3550	≤2.85	4000	≤0.7	48.6	920

### 馬達單體特性/ Motor Characteristics

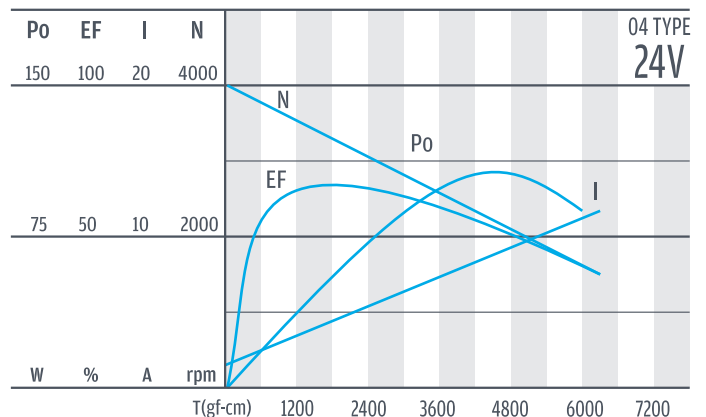
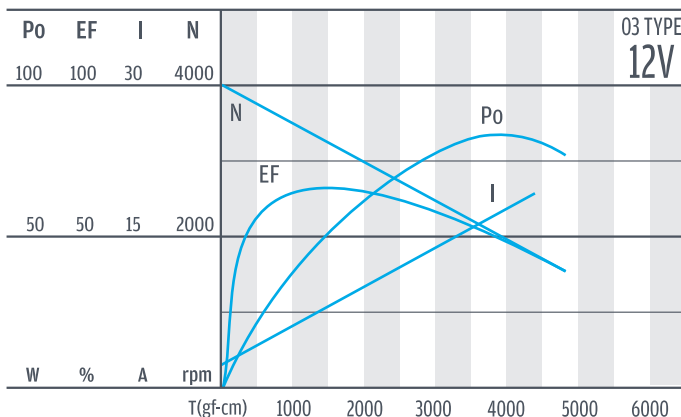

Encoder

Driver



# IG-52H



## 外形尺寸 & 馬達齒鉤合尺寸 / Appearance Size & Pinion Assembly Dimension

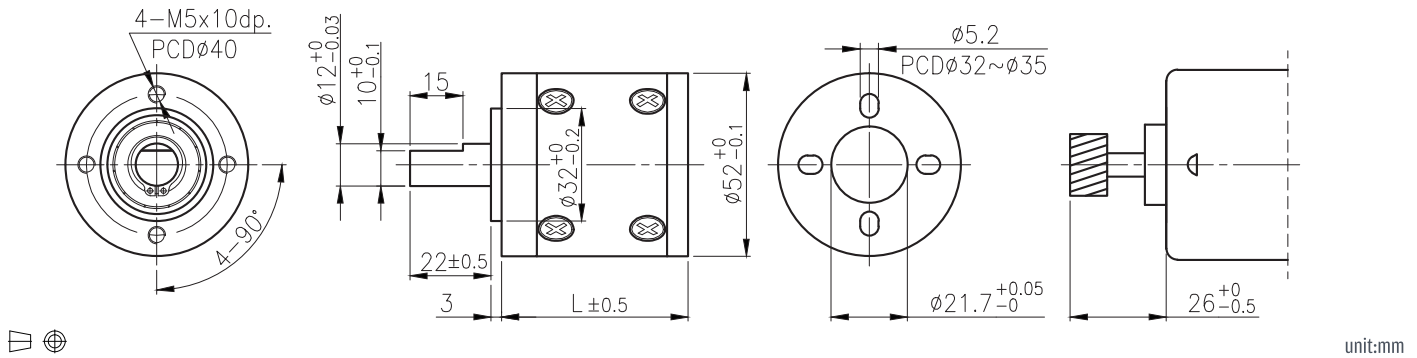

unit:mm

## 產品規格 / Product Specifications

外殼材質 Housing material	輸出軸承型式 Output shaft bearing	徑向負荷 Radial load (10mm from flange)	軸向負荷 Shaft axial load	主軸承受壓入力 Shaft press fit force	徑向間隙 Radial play of shaft	軸向間隙 Thrust play of shaft	背隙 (無負荷時) Backlash, at no-load
金屬 Metal	滾珠軸承 Ball bearings	≤ 20 kgf	≤ 10 kgf	≤ 30 kgf	≤ 0.04 mm	≤ 0.3 mm	≤ 3°

## 馬達齒輪型式 / Pinion Specifications

模數 Module	齒數 No. of teeth	螺旋角 Helix angle	壓力角 Pressure angle	孔徑 (mm) Hole diameter	減速比 Reduction ratio
0.8	16	18° (左, left)	20°	○ $\phi$ 6X4.5	1/4, 1/13, 1/46, 1/57, 1/98, 1/161
0.8	13	18° (左, left)	20°	○ $\phi$ 6X4.5	1/5, 1/15, 1/19, 1/67, 1/82, 1/114, 1/207, 1/288, 1/357, 1/494, 1/552, 1/684

## 標準減速比型式 / Gearboxes Specifications

減速比 Reduction ratio	1/4	1/5	1/13	1/15	1/19	1/46	1/57	1/67	1/82	1/98	1/114	1/161	1/207	1/288	1/357	1/494	1/552	1/684				
定格容許扭力 (kgf-cm max.) Rated tolerance torque	6	6	20	20	30	50	50	60	60	80	80	100	100	100	100	100	100	100				
瞬間容許扭力 (kgf-cm) Max momentary tolerance torque	18	18	60	60	90	150	150	180	180	240	240	300	300	300	300	300	300	300				
效率 Efficiency	80%	80%	70%	70%	70%	60%	60%	60%	60%	60%	60%	50%	50%	50%	50%	50%	50%	50%				
長度 Length (L)	53	53	68.5	68.5	68.5	84	84	84	84	84	84	99.5	99.5	99.5	99.5	99.5	99.5	99.5				
重量 (滾珠軸承) Weight (g) / Ball bearings	445	445	630	630	630	820	820	820	820	820	820	990	990	990	990	990	990	990				

- 使用相對溼度：20%~85%RH  
Operating relative humidity
- 使用溫度範圍：-10°C~+60°C  
Operating temperature range

IG

# IG-52HGM

## 03 & 04 TYPE



Right Angle

### 外形尺寸/ Appearance Size

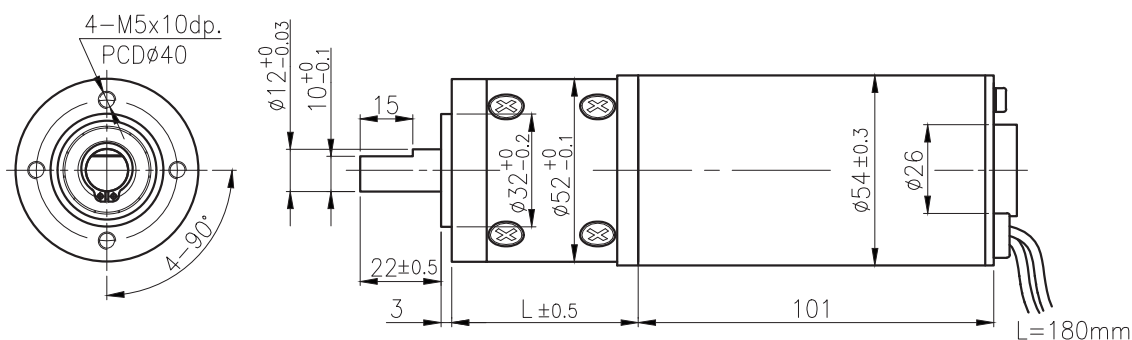

unit:mm

RA

RB

### 齒輪箱馬達轉矩 & 速度/ Gear Motor Torque & Speed

	減速比 Reduction ratio	1/4	1/5	1/13	1/15	1/19	1/46	1/57	1/67	1/82	1/98	1/114	1/161	1/207	1/288	1/357	1/494	1/552	1/684	
12V	定格扭力 Rated torque (kgf-cm)	2.7	3.6	8	9.5	11	24	30	35	44	52	61	72	93	100	100	100	100	100	
	定格轉速 Rated speed (rpm)	960	724	275	235	190	78	63	54	44	37	31.7	22.5	17.4	12.7	10.5	7.6	6.7	5.5	
24V	定格扭力 Rated torque (kgf-cm)	3.9	5.2	11	13	17	35	44	51	64	76	88	100	100	100	100	100	100	100	
	定格轉速 Rated speed (rpm)	940	710	270	230	186	77	62	53	43	36	31.1	22	17.3	12.7	10.5	7.6	6.7	5.5	
	軸心迴轉方向 Rotation direction	CW																		
	長度 Length (L)	53.0			68.5			84.0			99.5									

WG

PG

### 馬達單體型式/ Motor Data

定格電壓 Rated volt (V)	定格扭力 Rated torque (gf-cm)	定格轉速 Rated speed (rpm)	定格電流 Rated current (A)	無負荷轉速 No load speed (rpm)	無負荷電流 No load current (A)	定格出力 Rated output (W)	重量 Weight (g)
12	900	3620	≤4.1	4000	≤1.2	33.5	920
24	1300	3550	≤2.85	4000	≤0.7	48.6	920

### 馬達單體特性/ Motor Characteristics

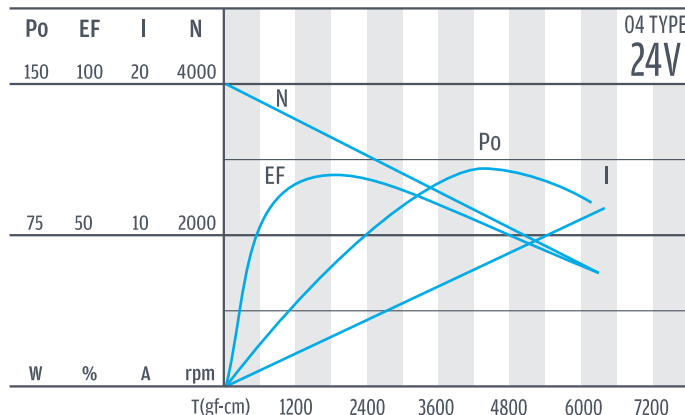
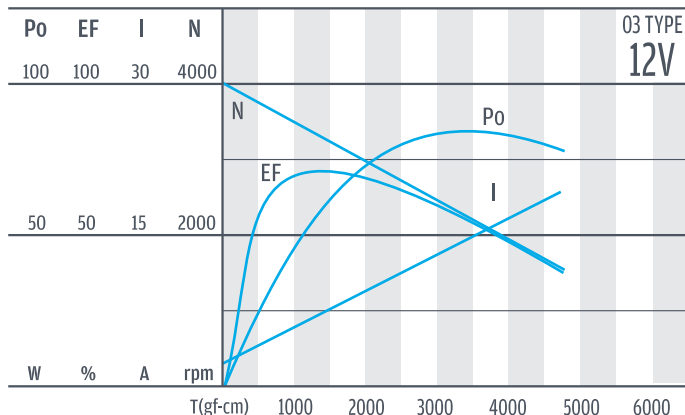

Encoder

Driver

# IG-60W



外形尺寸 & 馬達齒鉤合尺寸 / Appearance Size & Pinion Assembly Dimension

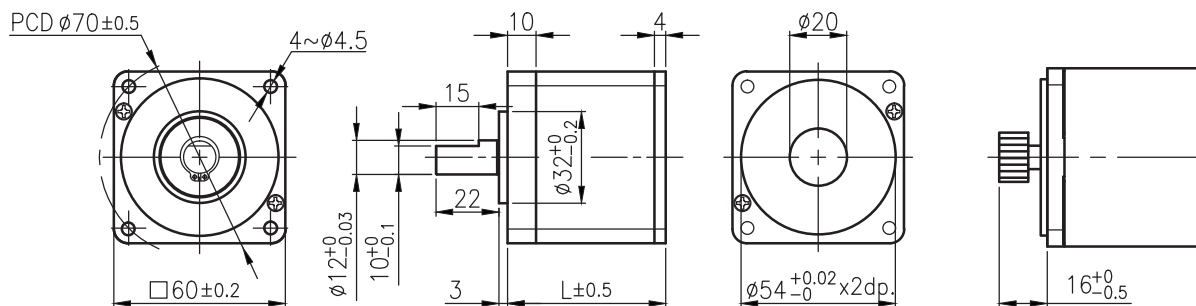

unit:mm

## 產品規格 / Product Specifications

外殼材質 Housing material	輸出軸承型式 Output shaft bearing	徑向負荷 Radial load (10mm from flange)	軸向負荷 Shaft axial load	主軸承受壓入力 Shaft press fit force	徑向間隙 Radial play of shaft	軸向間隙 Thrust play of shaft	背隙 (無負荷時) Backlash, at no-load
金屬 Metal	滾珠軸承 Ball bearings	$\leq 20$ kgf	$\leq 10$ kgf	$\leq 30$ kgf	$\leq 0.08$ mm	$\leq 0.4$ mm	$\leq 3^\circ$

## 馬達齒輪型式 / Pinion Specifications

模數 Module	齒數 No. of teeth	壓力角 Pressure angle	孔徑 (mm) Hole diameter	減速比 Reduction ratio
1.0	12	$20^\circ$	$\phi 6 \times 4.5$	1/4, 1/15, 1/19, 1/53, 1/66, 1/81, 1/113, 1/230 1/285, 1/353, 1/488, 1/546, 1/676
1.0	14	$20^\circ$	$\phi 8 \times 6$	1/100
1.0	16	$20^\circ$	$\phi 8 \times 6$	1/3, 1/12, 1/43, 1/150

## 標準減速比型式 / Gearboxes Specifications

減速比 Reduction ratio	1/3	1/4	1/12	1/15	1/19	1/43	1/53	1/66	1/81	1/100	1/113	1/150	1/230	1/285	1/353	1/488	1/546	1/676
定格容許扭力 (kgf-cm max.) Rated tolerance torque	15	15	50	50	50	100	100	100	100	100	100	100	100	100	100	100	100	100
瞬間容許扭力 (kgf-cm) Max momentary tolerance torque	45	45	150	150	150	300	300	300	300	300	300	300	300	300	300	300	300	300
效率 Efficiency	80%	80%	70%	70%	70%	60%	60%	60%	60%	60%	60%	50%	50%	50%	50%	50%	50%	50%
長度 Length (L)	43.3	43.3	58.8	58.8	58.8	74.3	74.3	74.3	74.3	74.3	74.3	89.8	89.8	89.8	89.8	89.8	89.8	89.8
重量 (滾珠軸承) Weight (g) / Ball bearings	510	510	730	730	730	980	980	980	980	980	980	1210	1210	1210	1210	1210	1210	1210

- 使用相對溼度：20%~85%RH  
Operating relative humidity
- 使用溫度範圍：-10°C~+60°C  
Operating temperature range

IG

# IG-60WGM

## 01 & 02 TYPE

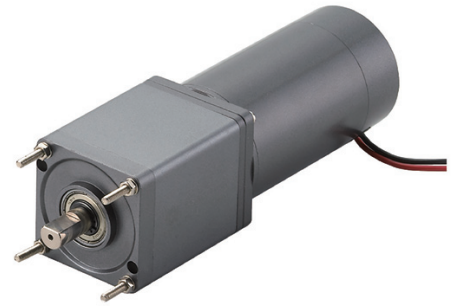

Right Angle

### 外形尺寸/ Appearance Size

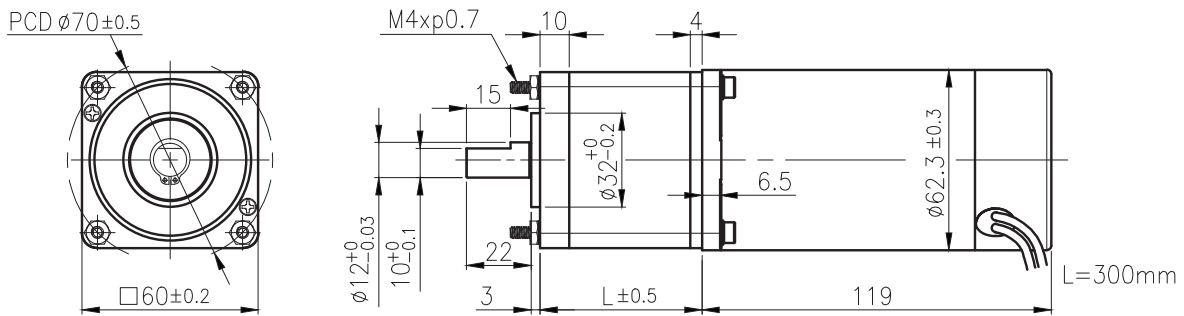

unit:mm

RA

RB

### 齒輪箱馬達轉矩 & 速度/ Gear Motor Torque & Speed

		減速比 Reduction ratio	1/3	1/4	1/12	1/15	1/19	1/43	1/53	1/66	1/81	1/100	1/113	1/150	1/230	1/285	1/353	1/488	1/546	1/676
12V	定格扭力 Rated torque (kgf-cm)		1.9	2.4	6	7.4	9	18	22	27	34	42	47	52	80	99	100	100	100	100
	定格轉速 Rated speed (rpm)		1350	1090	385	310	250	110	89	72	58	47	42	31.5	20.5	16.5	13.6	9.8	8.9	7.2
24V	定格扭力 Rated torque (kgf-cm)		2.7	3.4	8.5	10.5	13	25	31	39	48	60	67	75	100	100	100	100	100	100
	定格轉速 Rated speed (rpm)		1380	1100	390	310	255	110	90	73	59	48	42	32	21	17.1	13.8	10	9	7.3
軸心迴轉方向 Rotation direction			CW																	
長度 Length (L)			43.3			58.8			74.3			89.8								

WG

PG

### 馬達單體型式/ Motor Data

定格電壓 Rated volt (V)	定格扭力 Rated torque (gf-cm)	定格轉速 Rated speed (rpm)	定格電流 Rated current (A)	無負荷轉速 No load speed (rpm)	無負荷電流 No load current (A)	定格出力 Rated output (W)	重量 Weight (g)
12	700	4760	≤3.3	5100	≤1.5	34.2	1150
24	1000	4830	≤2.4	5100	≤0.8	49.6	1150

### 馬達單體特性/ Motor Characteristics

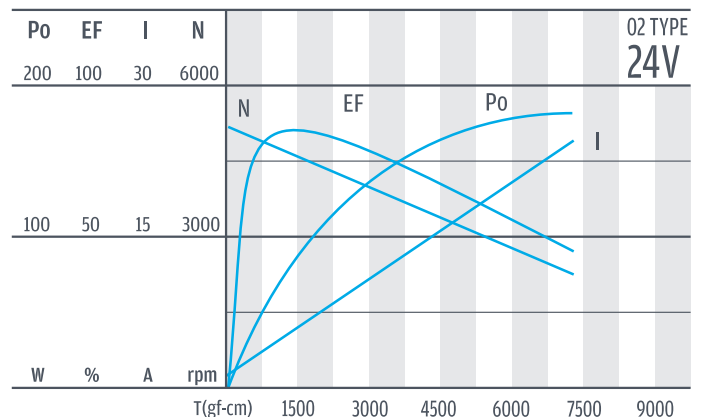
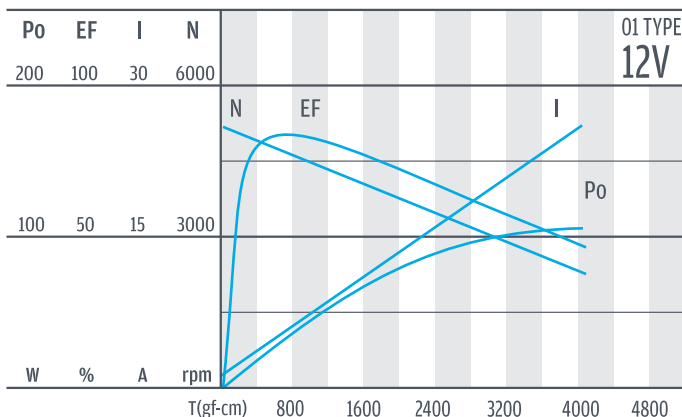

Encoder

Driver

# IG-60WGM

## 41 TYPE



### 外形尺寸/ Appearance Size

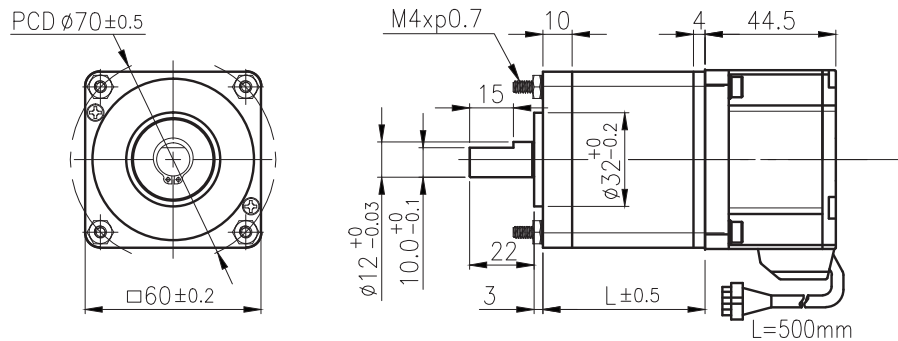

unit:mm

### 齒輪箱馬達轉矩 & 速度/ Gear Motor Torque & Speed

減速比 Reduction ratio	1/3	1/4	1/12	1/15	1/19	1/43	1/53	1/66	1/81	1/100	1/113	1/150	1/230	1/285	1/353	1/488	1/546	1/676		
24V 定格扭力 Rated torque (kgf-cm)	3.3	4.1	10	12.6	15.8	30.8	38	47.5	58	72	81	90	100	100	100	100	100	100		
24V 定格轉速 Rated speed (rpm)	714	576	204	164	133	58	47	38	30.7	25	22.1	16.6	10.8	8.7	7.1	5.1	4.5	3.6		
長度 Length (L)	43.3		58.8			74.3						89.8								

### 馬達單體型式/ Motor Data

定格電壓 Rated volt (V)	24	定格扭力 Rated torque (gf-cm)	1200	定格轉速 Rated speed (rpm)	2500	定格電流 Rated current (A)	$\leq 1.8$	無負荷轉速 No load speed (rpm)	3000	無負荷電流 No load current (A)	$\leq 0.4$	定格出力 Rated output (W)	30.81	重量 Weight (g)	500
啟動扭力 Start torque (gf-cm)	1500	絕緣抗耐 Insulation voltage	60HZ AC500V	絕緣阻抗 Insulation resistance	100M $\Omega$ DC500V	絕緣等級 Insulation class	A class (105°C)	使用相對溼度 Operating relative humidity	20%-85%RH	使用溫度範圍 Operating temperature range	0~+50°C				

### 馬達單體特性/ Motor Characteristics

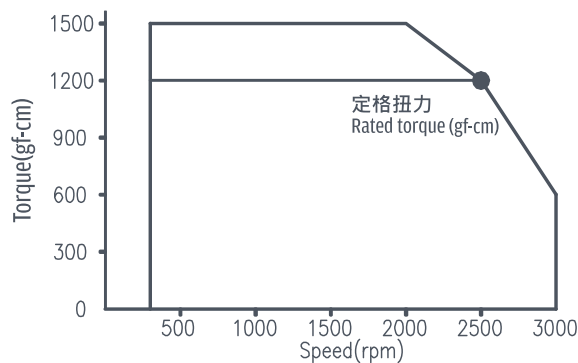

### 搭配之驅動器型式/ Connected With Motor Driver

型號 Type	DBMC30-3
輸入電壓 Input voltage	DC 24V $\pm 10\%$
速度控制範圍 Speed control range	300~3000 rpm
速度設定方式 Speed control way	1. 內部速度設定 Internal control 2. 外部速度設定 External speed control 3. 外部直流電壓控制 (DC 0~5V) External voltage control (DC 0~5V)

IG

# IG-62



Right Angle

## 外形尺寸 & 馬達齒鉤合尺寸 / Appearance Size & Pinion Assembly Dimension

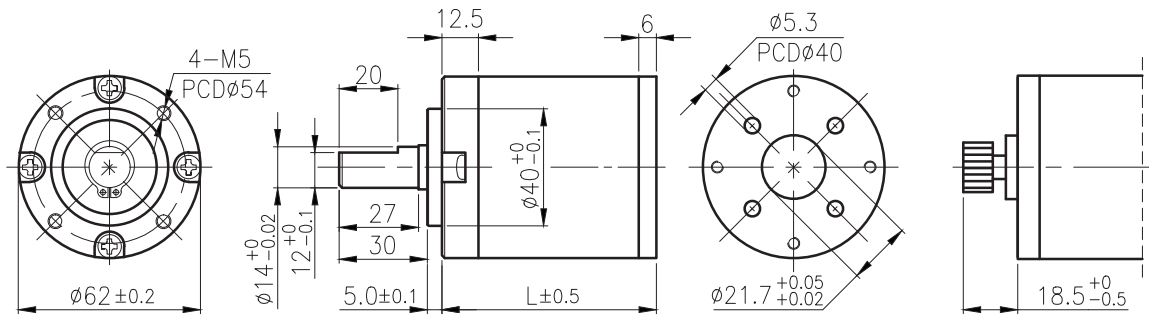

unit:mm

RA

## 產品規格 / Product Specifications

外殼材質 Housing material	輸出軸承型式 Output shaft bearing	徑向負荷 Radial load (10mm from flange)	軸向負荷 Shaft axial load	主軸承受壓入力 Shaft press fit force	徑向間隙 Radial play of shaft	軸向間隙 Thrust play of shaft	背隙 (無負荷時) Backlash, at no-load
金屬 Metal	滾珠軸承 Ball bearings	$\leq 25$ kgf	$\leq 10$ kgf	$\leq 50$ kgf	$\leq 0.08$ mm	$\leq 0.4$ mm	$\leq 3^\circ$

RB

## 馬達齒輪型式 / Pinion Specifications

模數 Module	齒數 No. of teeth	壓力角 Pressure angle	孔徑 (mm) Hole diameter	減速比 Reduction ratio
1.0	12	$20^\circ$	$\phi 6 \times 4.5$	1/4, 1/15, 1/19, 1/53, 1/66, 1/81, 1/113, 1/230 1/285, 1/353, 1/488, 1/546, 1/676
1.0	14	$20^\circ$	$\phi 8 \times 6$	1/100
1.0	16	$20^\circ$	$\phi 8 \times 6$	1/3, 1/12, 1/43, 1/150

WG

## 標準減速比型式 / Gearboxes Specifications

減速比 Reduction ratio	1/3	1/4	1/12	1/15	1/19	1/43	1/53	1/66	1/81	1/100	1/113	1/150	1/230	1/285	1/353	1/488	1/546	1/676
定格容許扭力 (kgf-cm max.) Rated tolerance torque	15	15	50	50	50	100	100	100	100	100	100	100	100	100	100	100	100	100
瞬間容許扭力 (kgf-cm) Max momentary tolerance torque	45	45	150	150	150	300	300	300	300	300	300	300	300	300	300	300	300	300
效率 Efficiency	80%	80%	70%	70%	70%	60%	60%	60%	60%	60%	60%	50%	50%	50%	50%	50%	50%	50%
長度 Length (L)	43.6	43.6	59.1	59.1	59.1	74.6	74.6	74.6	74.6	74.6	74.6	90.1	90.1	90.1	90.1	90.1	90.1	90.1
重量 (滾珠軸承) Weight (g) /Ball bearings	670	670	940	940	940	1220	1220	1220	1220	1220	1220	1500	1500	1500	1500	1500	1500	1500

PG

Encoder

- 使用相對溼度：20%~85%RH  
Operating relative humidity
- 使用溫度範圍：-10°C~+60°C  
Operating temperature range

Driver

# IG-62GM

## 01 & 02 TYPE



### 外形尺寸/ Appearance Size

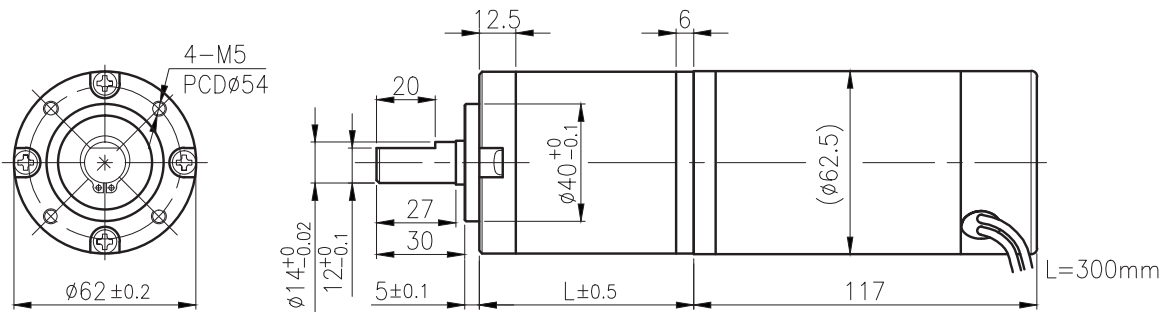

unit:mm

### 齒輪箱馬達轉矩 & 速度/ Gear Motor Torque & Speed

		1/3	1/4	1/12	1/15	1/19	1/43	1/53	1/66	1/81	1/100	1/113	1/150	1/230	1/285	1/353	1/488	1/546	1/676
12V	減速比 Reduction ratio	1/3	1/4	1/12	1/15	1/19	1/43	1/53	1/66	1/81	1/100	1/113	1/150	1/230	1/285	1/353	1/488	1/546	1/676
	定額轉速 Rated speed (rpm)	480	390	135	110	90	39.5	32	25.7	21	17	15	11	7.3	6	5	3.7	3.3	2.7
24V	定額轉速 Rated speed (rpm)	500	400	140	115	93	40.5	33	26.5	21.5	17.5	15.4	11.7	7.8	6.3	5.3	3.8	3.4	2.8
	定額扭力 Rated torque (kgf-cm)	2.5	3	7.5	9.4	11.8	23	28	35	43	54	61	67	100	100	100	100	100	100
軸心迴轉方向 Rotation direction		CW																	
長度 Length (L)		43.6			59.1			74.6			90.1								

### 馬達單體型式/ Motor Data

定額電壓 Rated volt (V)	定額扭力 Rated torque (gf-cm)	定額轉速 Rated speed (rpm)	定額電流 Rated current (A)	無負荷轉速 No load speed (rpm)	無負荷電流 No load current (A)	定額出力 Rated output (W)	重量 Weight (g)
12	900	1700	≤1.8	2000	≤0.45	15.7	1650
24	1500	1750	≤1.5	2000	≤0.3	26.9	1650

### 馬達單體特性/ Motor Characteristics

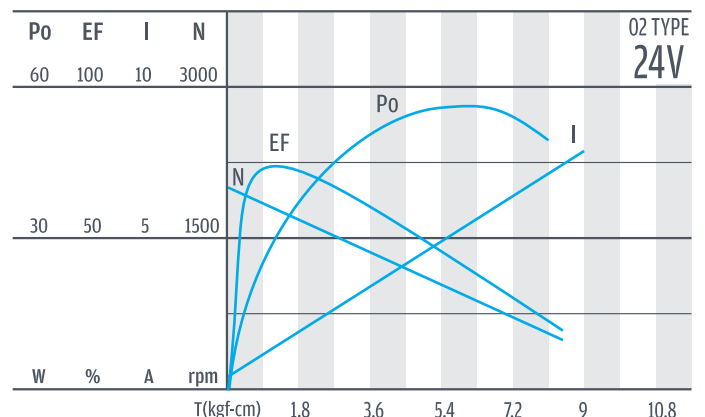
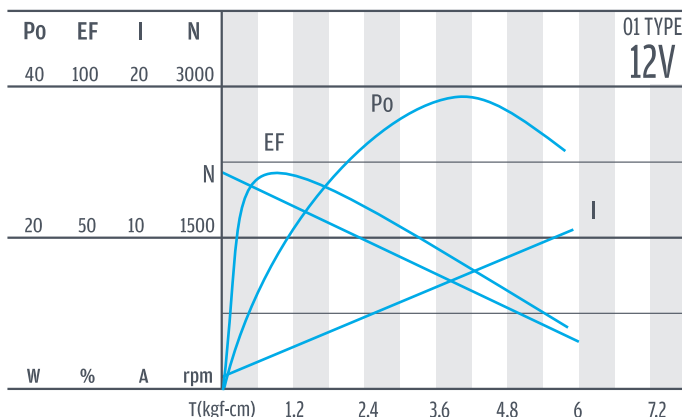



IG

# IG-70W



Right Angle

## 外形尺寸 & 馬達齒鉚合尺寸 / Appearance Size & Pinion Assembly Dimension

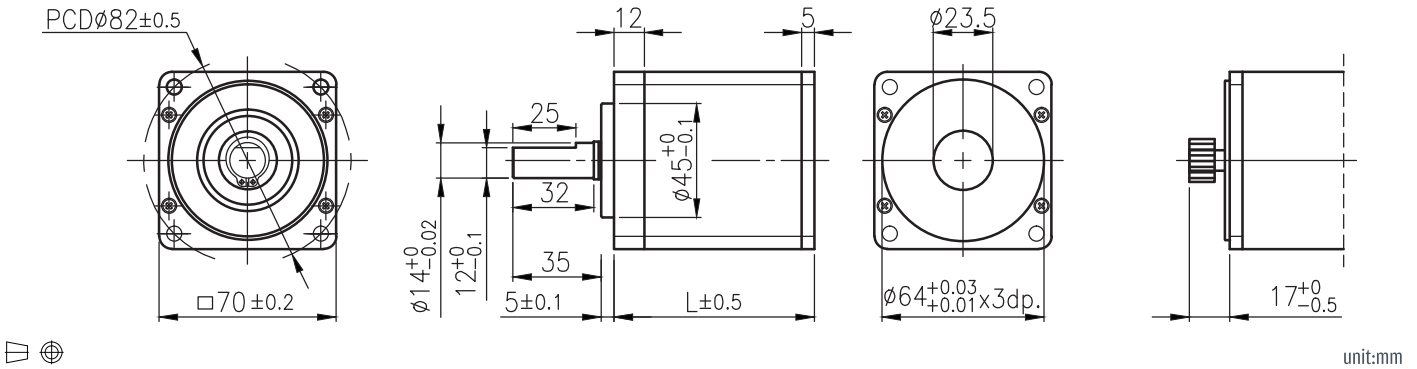

RA

## 產品規格 / Product Specifications

外殼材質 Housing material	輸出軸承型式 Output shaft bearing	徑向負荷 Radial load (10mm from flange)	軸向負荷 Shaft axial load	主軸承受壓入力 Shaft press fit force	徑向間隙 Radial play of shaft	軸向間隙 Thrust play of shaft	背隙 (無負荷時) Backlash, at no-load
金屬 Metal	滾珠軸承 Ball bearings	≤ 25 kgf	≤ 10 kgf	≤ 50 kgf	≤ 0.08 mm	≤ 0.4 mm	≤ 3°

RB

## 馬達齒輪型式 / Pinion Specifications

模數 Module	齒數 No. of teeth	壓力角 Pressure angle	孔徑 (mm) Hole diameter	減速比 Reduction ratio
1.0	13	20°	○ ø6X4.5	1/102, 1/126, 1/242, 1/300, 1/363, 1/493, 1/611
1.0	14	20°	○ ø8X6	1/16, 1/20, 1/60, 1/75, 1/91, 1/414, 1/543
1.0	18	20°	○ ø8X6	1/13, 1/50, 1/189
1.0	20	20°	○ ø8X6	1/4

WG

## 標準減速比型式 / Gearboxes Specifications

減速比 Reduction ratio	1/4	1/13	1/16	1/20	1/50	1/60	1/75	1/91	1/102	1/126	1/189	1/242	1/300	1/363	1/414	1/493	1/543	1/611
定格容許扭力 (kgf-cm max.) Rated tolerance torque	15	70	70	70	125	125	125	125	125	125	125	125	125	125	125	125	125	125
瞬間容許扭力 (kgf-cm) Max momentary tolerance torque	45	210	210	210	375	375	375	375	375	375	375	375	375	375	375	375	375	375
效率 Efficiency	80%	70%	70%	70%	60%	60%	60%	60%	60%	60%	50%	50%	50%	50%	50%	50%	50%	50%
長度 Length (L)	47.3	63.8	63.8	63.8	80.3	80.3	80.3	80.3	80.3	80.3	96.8	96.8	96.8	96.8	96.8	96.8	96.8	96.8
重量 (滾珠軸承) Weight (g) /Ball bearings	780	1110	1110	1110	1440	1440	1440	1440	1440	1440	1780	1780	1780	1780	1780	1780	1780	1780

PG

Encoder

Driver

- 使用相對溼度：20%~85%RH  
Operating relative humidity
- 使用溫度範圍：-10°C~+60°C  
Operating temperature range

# IG-70WGM

## 01 & 02 TYPE



### 外形尺寸/ Appearance Size

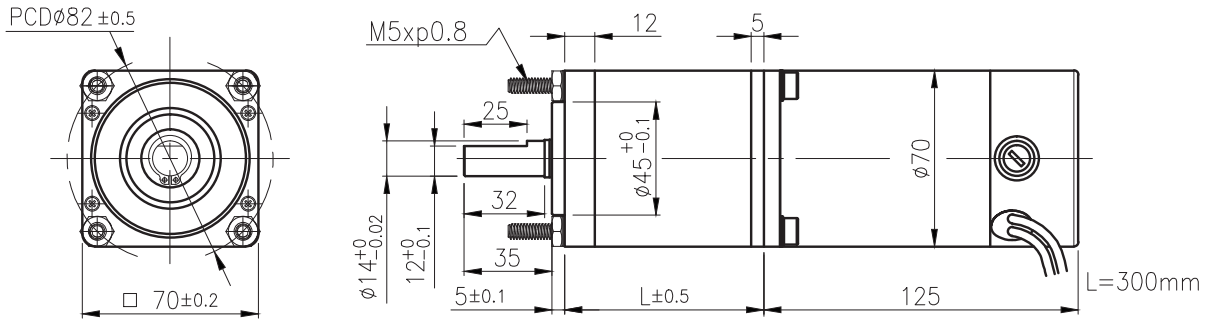

unit:mm

### 齒輪箱馬達轉矩 & 速度/ Gear Motor Torque & Speed

		減速比 Reduction ratio	1/4	1/13	1/16	1/20	1/50	1/60	1/75	1/91	1/102	1/126	1/189	1/242	1/300	1/363	1/414	1/493	1/543	1/611	
12V	定格扭力 Rated torque (kgf-cm)	4.2	13.8	16.8	20.4	44.9	54	67	81	91	113	125	125	125	125	125	125	125	125	125	
	定格轉速 Rated speed (rpm)	510	135	112	90.9	36	29.7	24	19.7	17.6	14.2	9.5	7.5	6.2	5.1	4.4	3.7	3.4	3		
24V	定格扭力 Rated torque (kgf-cm)	7	23.1	28	34.6	74.9	90.6	112	125	125	125	125	125	125	125	125	125	125	125	125	
	定格轉速 Rated speed (rpm)	510	135	112	90.9	36	29.7	24	19.8	17.7	14.3	9.6	7.6	6.3	5.2	4.5	3.8	3.5	3.1		
軸心迴轉方向 Rotation direction		CW																			
長度 Length (L)		47.3	63.8				80.3						96.8								

### 馬達單體型式/ Motor Data

定格電壓 Rated volt (V)	定格扭力 Rated torque (gf-cm)	定格轉速 Rated speed (rpm)	定格電流 Rated current (A)	無負荷轉速 No load speed (rpm)	無負荷電流 No load current (A)	定格出力 Rated output (W)	重量 Weight (g)
12	1500	1800	≤3.0	2000	≤0.8	27.7	1650
24	2500	1800	≤2.5	2000	≤0.4	46.2	1650

### 馬達單體特性/ Motor Characteristics

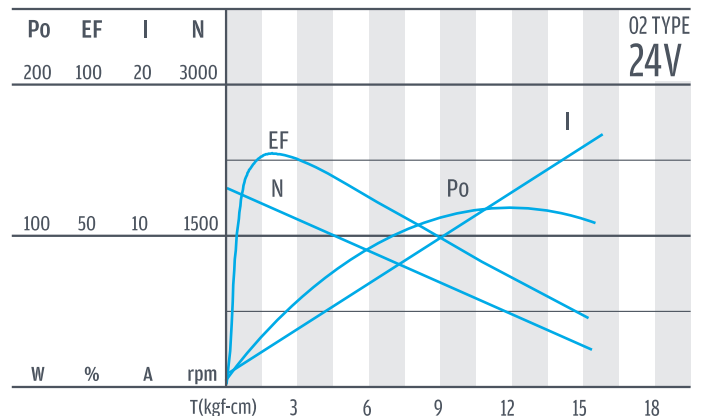
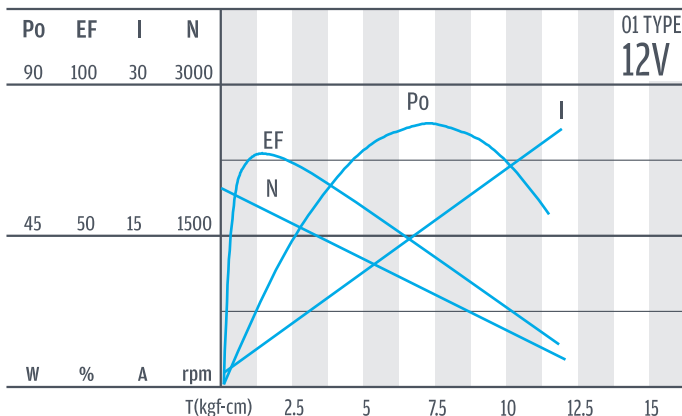

IG

# IG-71



Right Angle

## 外形尺寸 & 馬達齒銜尺寸 / Appearance Size & Pinion Assembly Dimension

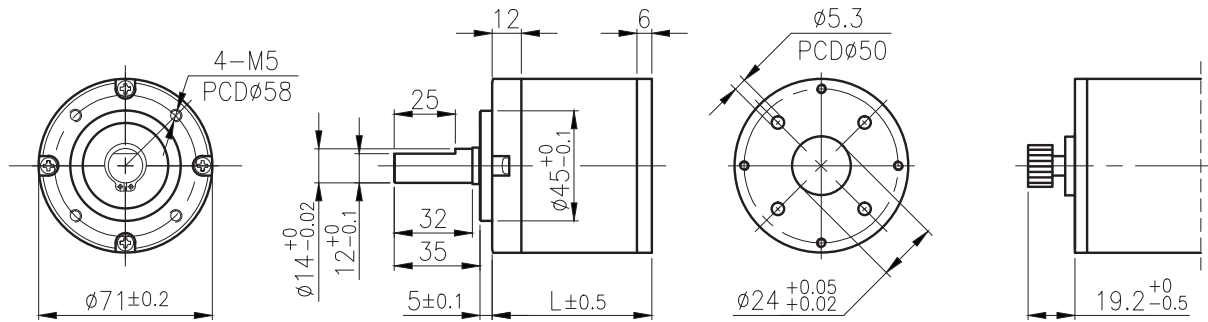

unit:mm

RA

## 產品規格/ Product Specifications

外殼材質 Housing material	輸出軸承型式 Output shaft bearing	徑向負荷 Radial load (10mm from flange)	軸向負荷 Shaft axial load	主軸承受壓入力 Shaft press fit force	徑向間隙 Radial play of shaft	軸向間隙 Thrust play of shaft	背隙 (無負荷時) Backlash, at no-load
金屬 Metal	滾珠軸承 Ball bearings	$\leq 25$ kgf	$\leq 10$ kgf	$\leq 50$ kgf	$\leq 0.08$ mm	$\leq 0.4$ mm	$\leq 3^\circ$

RB

## 馬達齒輪型式/ Pinion Specifications

模數 Module	齒數 No. of teeth	壓力角 Pressure angle	孔徑 (mm) Hole diameter	減速比 Reduction ratio
1.0	13	$20^\circ$	$\phi 6 \times 4.5$	1/102, 1/126, 1/242, 1/300, 1/363, 1/493, 1/611
1.0	14	$20^\circ$	$\phi 8 \times 6$	1/16, 1/20, 1/60, 1/75, 1/91, 1/414, 1/543
1.0	18	$20^\circ$	$\phi 8 \times 6$	1/13, 1/50, 1/189
1.0	20	$20^\circ$	$\phi 8 \times 6$	1/4

WG

## 標準減速比型式/ Gearboxes Specifications

減速比 Reduction ratio	1/4	1/13	1/16	1/20	1/50	1/60	1/75	1/91	1/102	1/126	1/189	1/242	1/300	1/363	1/414	1/493	1/543	1/611
定格容許扭力 (kgf-cm max.) Rated tolerance torque	15	70	70	70	125	125	125	125	125	125	125	125	125	125	125	125	125	125
瞬間容許扭力 (kgf-cm) Max momentary tolerance torque	45	210	210	210	375	375	375	375	375	375	375	375	375	375	375	375	375	375
效率 Efficiency	80%	70%	70%	70%	60%	60%	60%	60%	60%	60%	50%	50%	50%	50%	50%	50%	50%	50%
長度 Length (L)	49.3	65.8	65.8	65.8	82.3	82.3	82.3	82.3	82.3	82.3	98.8	98.8	98.8	98.8	98.8	98.8	98.8	98.8
重量 (滾珠軸承) Weight (g) /Ball bearings	900	1230	1230	1230	1560	1560	1560	1560	1560	1560	1900	1900	1900	1900	1900	1900	1900	1900

Encoder

Driver

- 使用相對溼度：20%~85%RH  
Operating relative humidity
- 使用溫度範圍：-10°C~+60°C  
Operating temperature range

# IG-71GM

## 01 & 02 TYPE



### 外形尺寸/ Appearance Size

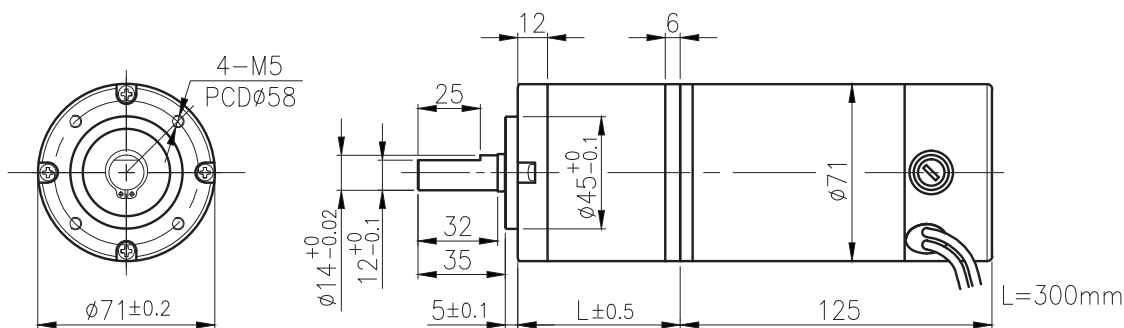

unit:mm

### 齒輪箱馬達轉矩 & 速度/ Gear Motor Torque & Speed

	減速比 Reduction ratio	1/4	1/13	1/16	1/20	1/50	1/60	1/75	1/91	1/102	1/126	1/189	1/242	1/300	1/363	1/414	1/493	1/543	1/611		
12V	定格扭力 Rated torque (kgf-cm)	4.2	13.8	16.8	20.4	44.9	54	67	81	91	113	125	125	125	125	125	125	125	125		
	定格轉速 Rated speed (rpm)	510	135	112	90.9	36	29.7	24	19.7	17.6	14.2	9.5	7.5	6.2	5.1	4.4	3.7	3.4	3.0		
24V	定格扭力 Rated torque (kgf-cm)	7	23.1	28	34.6	74.9	90.6	112	125	125	125	125	125	125	125	125	125	125	125		
	定格轉速 Rated speed (rpm)	510	135	112	90.9	36	29.7	24	19.8	17.7	14.3	9.6	7.6	6.3	5.2	4.5	3.8	3.5	3.1		
	軸心迴轉方向 Rotation direction	CW																			
	長度 Length (L)	49.3		65.8				82.3								98.8					

### 馬達單體型式/ Motor Data

定格電壓 Rated volt (V)	定格扭力 Rated torque (gf-cm)	定格轉速 Rated speed (rpm)	定格電流 Rated current (A)	無負荷轉速 No load speed (rpm)	無負荷電流 No load current (A)	定格出力 Rated output (W)	重量 Weight (g)
12	1500	1800	≤ 3	2000	≤ 0.8	27.7	1650
24	2500	1800	≤ 2.5	2000	≤ 0.4	46.2	1650

### 馬達單體特性/ Motor Characteristics

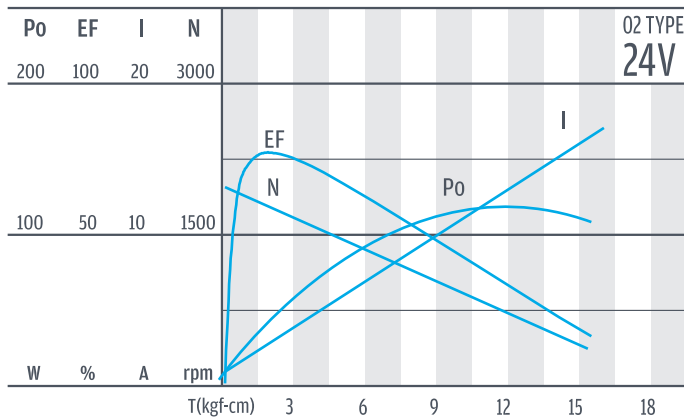
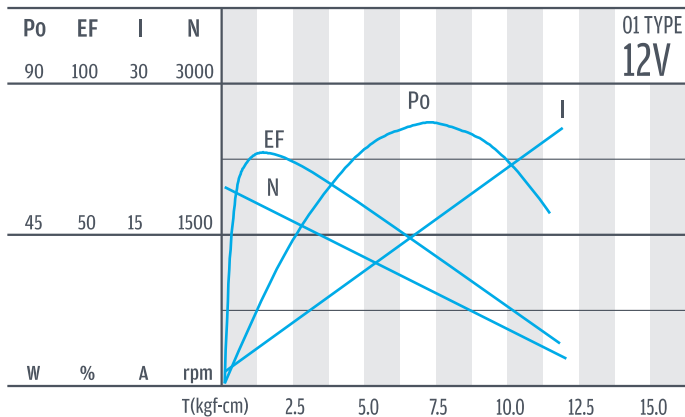

IG

# IG-80W

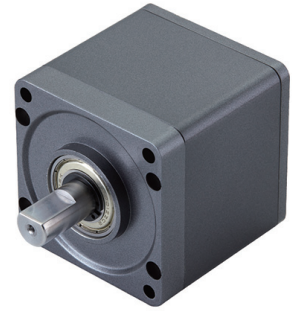

Right Angle

## 外形尺寸 & 馬達齒鉤尺寸 / Appearance Size & Pinion Assembly Dimension

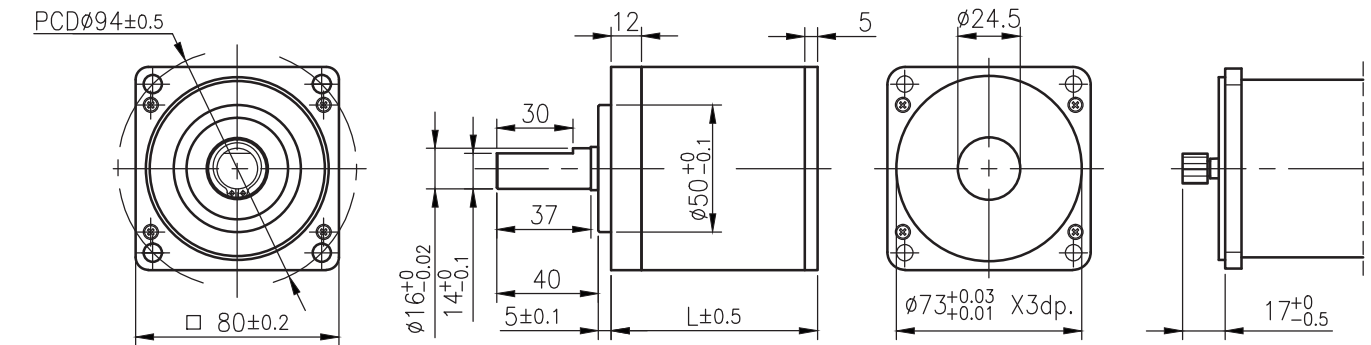

unit:mm

RA

## 產品規格 / Product Specifications

外殼材質 Housing material	輸出軸承型式 Output shaft bearing	徑向負荷 Radial load (10mm from flange)	軸向負荷 Shaft axial load	主軸承受壓入力 Shaft press fit force	徑向間隙 Radial play of shaft	軸向間隙 Thrust play of shaft	背隙 (無負荷時) Backlash, at no-load
金屬 Metal	滾珠軸承 Ball bearings	$\leq 30$ kgf	$\leq 10$ kgf	$\leq 75$ kgf	$\leq 0.08$ mm	$\leq 0.4$ mm	$\leq 3^\circ$

RB

## 馬達齒輪型式 / Pinion Specifications

模數 Module	齒數 No. of teeth	壓力角 Pressure angle	孔徑 (mm) Hole diameter	減速比 Reduction ratio
1.0	13	20°	$\phi$ 6X4.5	1/19, 1/21, 1/71, 1/80, 1/103, 1/117, 1/306 1/393, 1/445, 1/571, 1/647
1.0	21	20°	$\phi$ 8X6	1/13, 1/15, 1/49, 1/55, 1/186, 1/210

WG

## 標準減速比型式 / Gearboxes Specifications

減速比 Reduction ratio	1/4	1/13	1/15	1/19	1/21	1/49	1/55	1/71	1/80	1/103	1/117	1/186	1/210	1/306	1/393	1/445	1/571	1/647
定格容許扭力 (kgf-cm max.) Rated tolerance torque	15	70	70	70	70	125	125	125	125	125	125	125	125	125	125	125	125	125
瞬間容許扭力 (kgf-cm) Max momentary tolerance torque	45	210	210	210	210	375	375	375	375	375	375	375	375	375	375	375	375	375
效率 Efficiency	80%	70%	70%	70%	70%	60%	60%	60%	60%	60%	60%	50%	50%	50%	50%	50%	50%	50%
長度 Length (L)	49.3	65.8	65.8	65.8	65.8	82.3	82.3	82.3	82.3	82.3	82.3	98.8	98.8	98.8	98.8	98.8	98.8	98.8
重量 (滾珠軸承) Weight (g) /Ball bearings	1100	1570	1570	1570	1570	2040	2040	2040	2040	2040	2040	2510	2510	2510	2510	2510	2510	2510

PG

Encoder

- 使用相對溼度：20%~85%RH  
Operating relative humidity
- 使用溫度範圍：-10°C~+60°C  
Operating temperature range

Driver

# IG-80WGM

## 01 & 02 TYPE



### 外形尺寸/ Appearance Size

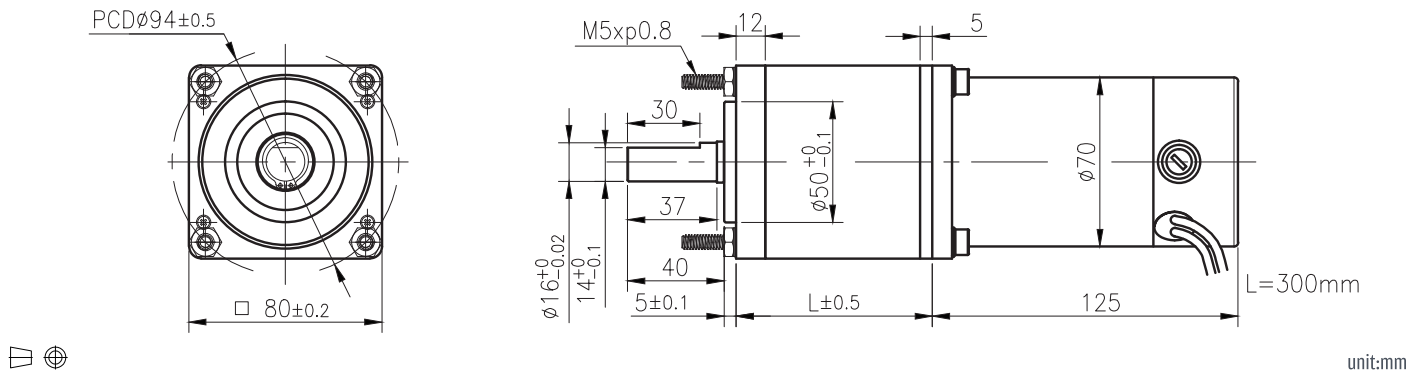

### 齒輪箱馬達轉矩 & 速度/ Gear Motor Torque & Speed

	減速比 Reduction ratio	1/4	1/13	1/15	1/19	1/21	1/49	1/55	1/71	1/80	1/103	1/117	1/186	1/210	1/306	1/393	1/445	1/571	1/647
12V	定格扭力 Rated torque (kgf-cm)	6	18	20	26	29	58	66	85	96	123	125	125	125	125	125	125	125	125
	定格轉速 Rated speed (rpm)	720	210	185	145	130	56	49	38	34	26.5	23.5	15	13.4	9.3	7.3	6.5	5.1	4.5
24V	定格扭力 Rated torque (kgf-cm)	8.8	26	29	37	42	84	95	123	125	125	125	125	125	125	125	125	125	125
	定格轉速 Rated speed (rpm)	730	215	190	149	133	57	50	39	35	27.5	24	15.4	13.7	9.6	7.5	6.7	5.2	4.6
	軸心迴轉方向 Rotation direction	CW																	
	長度 Length (L)	49.3			65.8				82.3					98.8					

### 馬達單體型式/ Motor Data

定格電壓 Rated volt (V)	定格扭力 Rated torque (gf-cm)	定格轉速 Rated speed (rpm)	定格電流 Rated current (A)	無負荷轉速 No load speed (rpm)	無負荷電流 No load current (A)	定格出力 Rated output (W)	重量 Weight (g)
12	2000	2750	≤ 6.3	3200	≤ 1.4	56.5	1650
24	2900	2800	≤ 4.4	3200	≤ 0.85	83.4	1650

### 馬達單體特性/ Motor Characteristics

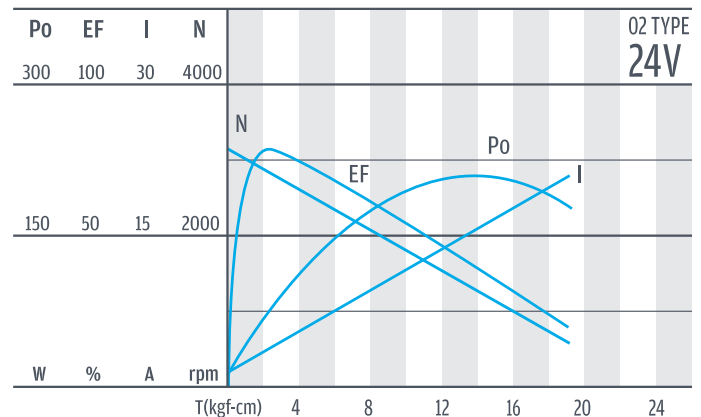
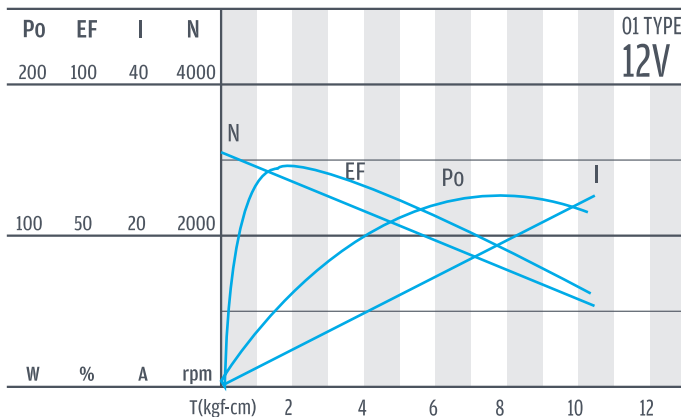

IG

# IG-80WGM

## 41 TYPE



Right Angle

### 外形尺寸/ Appearance Size

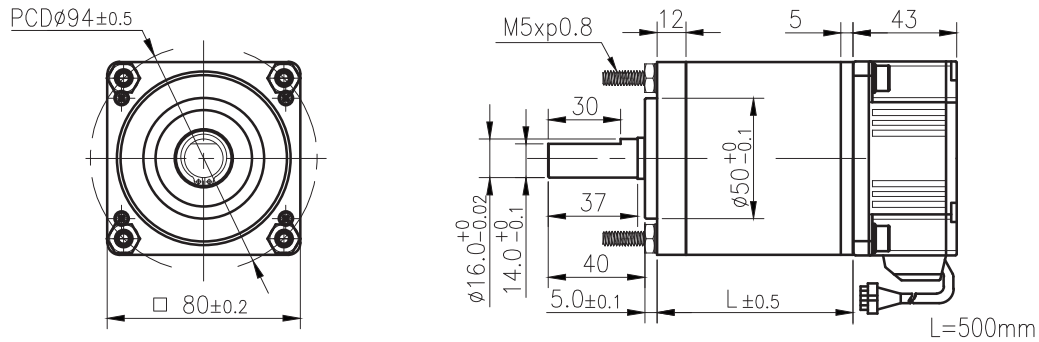

unit:mm

RA

RB

### 齒輪箱馬達轉矩 & 速度/ Gear Motor Torque & Speed

減速比 Reduction ratio	1/4	1/13	1/15	1/19	1/21	1/49	1/55	1/71	1/80	1/103	1/117	1/186	1/210	1/306	1/393	1/445	1/571	1/647
24V 定格扭力 Rated torque (kgf-cm)	6	17.9	20	26	29	58	66	85	96	123	125	125	125	125	125	125	125	125
24V 定格轉速 Rated speed (rpm)	657	195	172	134	119	51	45	35	31.2	24.2	21.3	13.4	11.9	8.1	6.3	5.6	4.3	3.8
長度 Length (L)	49.3		65.8			82.3						98.8						

WG

### 馬達單體型式/ Motor Data

定格電壓 Rated volt (V)	定格扭力 Rated torque (gf-cm)	定格轉速 Rated speed (rpm)	定格電流 Rated current (A)	無負荷轉速 No load speed (rpm)	無負荷電流 No load current (A)	定格出力 Rated output (W)	重量 Weight (g)
24	2000	2500	≤3.2	3000	≤0.45	51.35	800
啟動扭力 Start torque (gf-cm)	絕緣抗耐 Insulation voltage	絕緣阻抗 Insulation resistance	絕緣等級 Insulation class	使用相對溼度 Operating relative humidity	使用溫度範圍 Operating temperature range		
2400	60HZ AC500V	100MΩ DC500V	A class (105°C)	20%~85%RH	0~+50°C		

PG

### 馬達單體特性/ Motor Characteristics

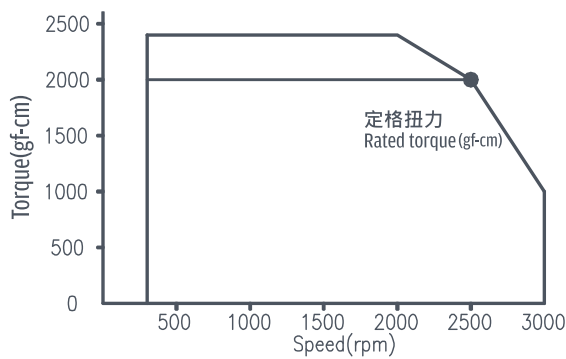

### 搭配之驅動器型式/ Connected With Motor Driver

型號 Type	DBMC50-3
輸入電壓 Input voltage	DC 24V±10%
速度控制範圍 Speed control range	300~3000 rpm
速度設定方式 Speed control way	1. 內部速度設定 Internal control 2. 外部速度設定 External speed control 3. 外部直流電壓控制 (DC 0~5V) External voltage control (DC 0~5V)

Driver



# IG-80



外形尺寸 & 馬達齒鉤合尺寸 / Appearance Size & Pinion Assembly Dimension

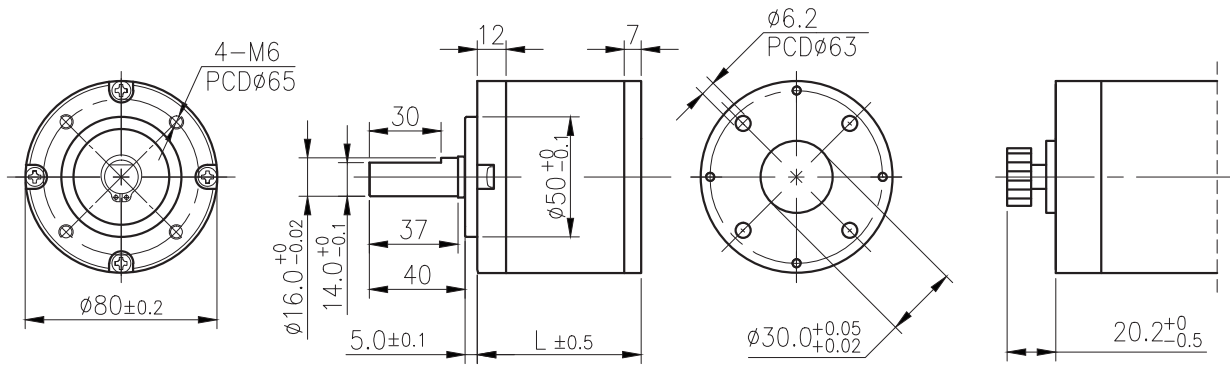

unit:mm

## 產品規格 / Product Specifications

外殼材質 Housing material	輸出軸承型式 Output shaft bearing	徑向負荷 Radial load (10mm from flange)	軸向負荷 Shaft axial load	主軸承受壓力 Shaft press fit force	徑向間隙 Radial play of shaft	軸向間隙 Thrust play of shaft	背隙 (無負荷時) Backlash, at no-load
金屬 Metal	滾珠軸承 Ball bearings	$\leq 30$ kgf	$\leq 10$ kgf	$\leq 75$ kgf	$\leq 0.08$ mm	$\leq 0.4$ mm	$\leq 3^\circ$

## 馬達齒輪型式 / Pinion Specifications

模數 Module	齒數 No. of teeth	壓力角 Pressure angle	孔徑 (mm) Hole diameter	減速比 Reduction ratio
1.0	13	$20^\circ$	$\varnothing 6 \times 4.5$	1/19, 1/21, 1/71, 1/80, 1/103, 1/117, 1/306 1/393, 1/445, 1/571, 1/647
1.0	21	$20^\circ$	$\varnothing 10 \times 8$	1/4, 1/13, 1/15, 1/49, 1/55, 1/186, 1/210

## 標準減速比型式 / Gearboxes Specifications

減速比 Reduction ratio	1/4	1/13	1/15	1/19	1/21	1/49	1/55	1/71	1/80	1/103	1/117	1/186	1/210	1/306	1/393	1/445	1/571	1/647
定格容許扭力 (kgf-cm max.) Rated tolerance torque	15	70	70	70	70	125	125	125	125	125	125	125	125	125	125	125	125	125
瞬間容許扭力 (kgf-cm) Max momentary tolerance torque	45	210	210	210	210	375	375	375	375	375	375	375	375	375	375	375	375	375
效率 Efficiency	80%	70%	70%	70%	70%	60%	60%	60%	60%	60%	60%	50%	50%	50%	50%	50%	50%	50%
長度 Length (L)	52.3	68.8	68.8	68.8	68.8	85.3	85.3	85.3	85.3	85.3	85.3	101.8	101.8	101.8	101.8	101.8	101.8	101.8
重量 (滾珠軸承) Weight (g) / Ball bearings	1200	1650	1650	1650	1650	2100	2100	2100	2100	2100	2100	2550	2550	2550	2550	2550	2550	2550

- 使用相對溼度：20%~85%RH  
Operating relative humidity
- 使用溫度範圍：-10°C~+60°C  
Operating temperature range

IG

# IG-80GM

## 01 & 02 TYPE



Right Angle

### 外形尺寸/ Appearance Size

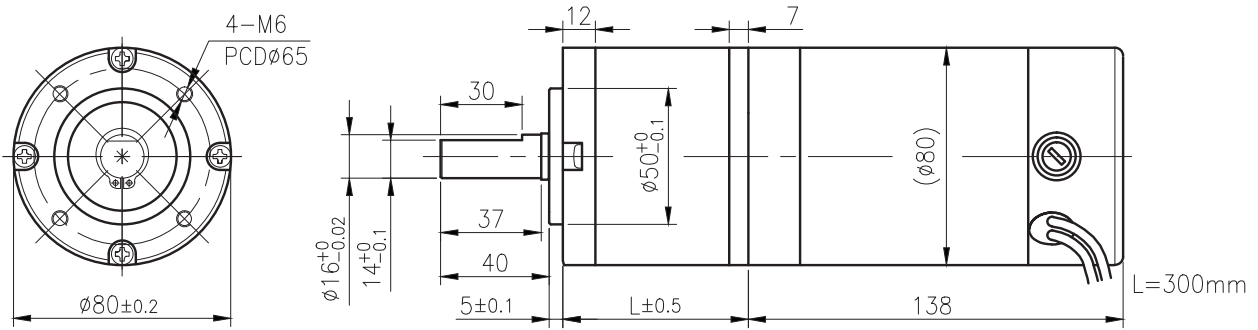

unit:mm

RA

RB

### 齒輪箱馬達轉矩 & 速度/ Gear Motor Torque & Speed

	減速比 Reduction ratio	1/4	1/13	1/15	1/19	1/21	1/49	1/55	1/71	1/80	1/103	1/117	1/186	1/210	1/306	1/393	1/445	1/571	1/647	
12V	定格扭力 Rated torque (kgf-cm)	7.6	22.4	25	32	36	73	82	105	120	125	125	125	125	125	125	125	125	125	
	定格轉速 Rated speed (rpm)	445	130	115	90	80	34	30	23.5	21	16.7	14.7	9.3	8.3	5.8	4.5	4	3.2	2.8	
24V	定格扭力 Rated torque (kgf-cm)	9.7	28.6	32	41	47	93	99	125	125	125	125	125	125	125	125	125	125	125	
	定格轉速 Rated speed (rpm)	470	140	124	95	85	36	32	25.5	23	17.8	15.6	9.9	8.8	6	4.7	4.2	3.3	2.9	
	軸心迴轉方向 Rotation direction	CW																		
	長度 Length (L)	52.3			68.8				85.3					101.8						

WG

PG

### 馬達單體型式/ Motor Data

定格電壓 Rated volt (V)	定格扭力 Rated torque (gf-cm)	定格轉速 Rated speed (rpm)	定格電流 Rated current (A)	無負荷轉速 No load speed (rpm)	無負荷電流 No load current (A)	定格出力 Rated output (W)	重量 Weight (g)
12	2500	1700	≤ 5.3	2000	≤ 1.1	43.6	1650
24	3200	1800	≤ 3.4	2000	≤ 0.6	59	1650

### 馬達單體特性/ Motor Characteristics

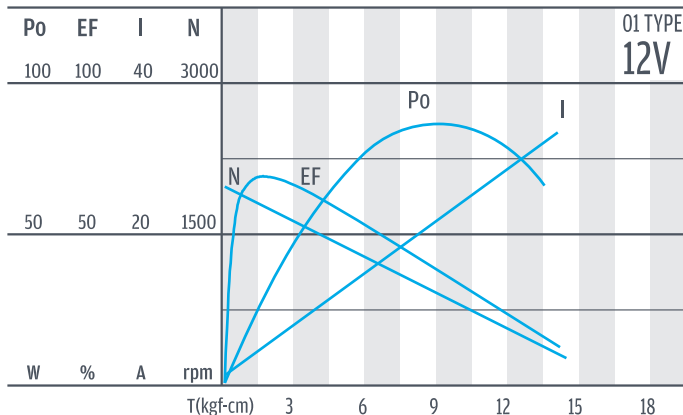

Encoder

Driver

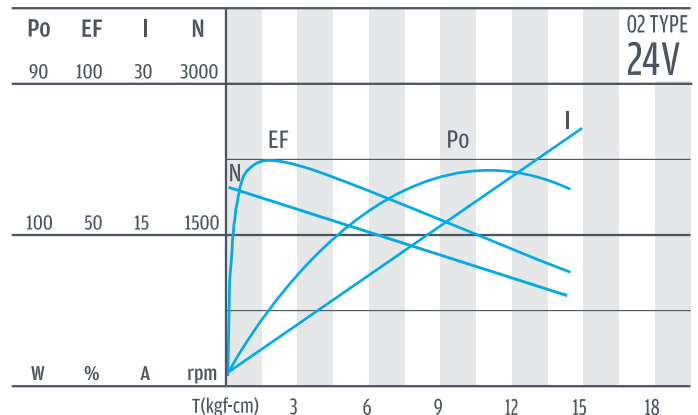

# IG-90W



## 外形尺寸 & 馬達齒鉋合尺寸 / Appearance Size & Pinion Assembly Dimension

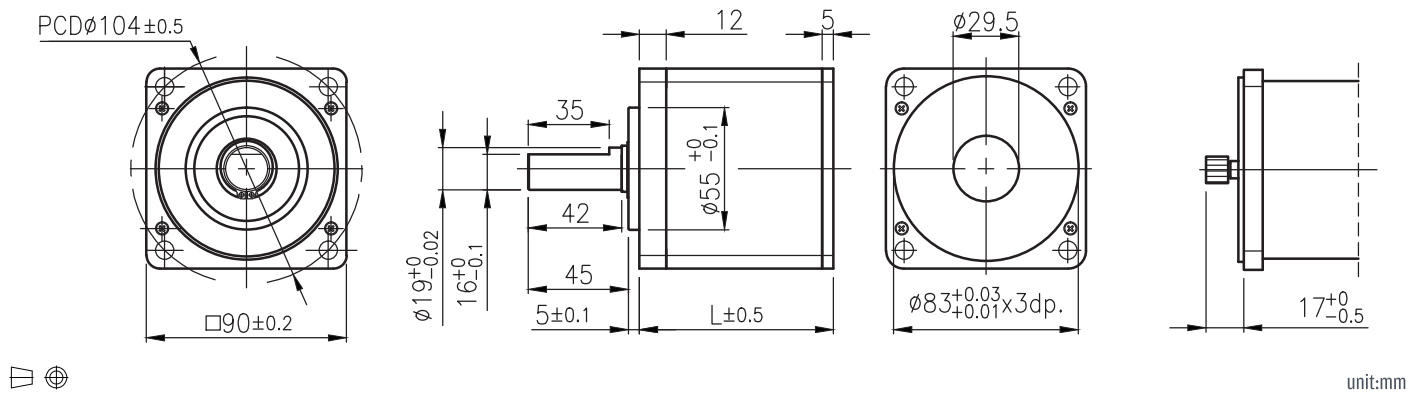

## 產品規格/ Product Specifications

外殼材質 Housing material	輸出軸承型式 Output shaft bearing	徑向負荷 Radial load (10mm from flange)	軸向負荷 Shaft axial load	主軸承受壓入力 Shaft press fit force	徑向間隙 Radial play of shaft	軸向間隙 Thrust play of shaft	背隙 (無負荷時) Backlash, at no-load
金屬 Metal	滾珠軸承 Ball bearings	≤ 40 kgf	≤ 10 kgf	≤ 100 kgf	≤ 0.08 mm	≤ 0.4 mm	≤ 4°

## 馬達齒輪型式/ Pinion Specifications

模數 Module	齒數 No. of teeth	壓力角 Pressure angle	孔徑 (mm) Hole diameter	減速比 Reduction ratio
1.0	16	20°	○ Ø10X8	1/19, 1/77, 1/98, 1/294, 1/403, 1/517
1.0	22	20°	○ Ø10X8	1/15, 1/60
1.0	24	20°	○ Ø10X8	1/52, 1/201
1.25	21	20°	○ Ø10X8	1/4

## 標準減速比型式/ Gearboxes Specifications

減速比 Reduction ratio	1/4	1/15	1/19	1/52	1/60	1/77	1/98	1/201	1/294	1/403	1/517
定格容許扭力 (kgf-cm max.) Rated tolerance torque	20	80	80	150	150	150	150	180	180	180	180
瞬間容許扭力 (kgf-cm) Max momentary tolerance torque	60	240	240	450	450	450	450	540	540	540	540
效率 Efficiency	80%	70%	70%	60%	60%	60%	60%	50%	50%	50%	50%
長度 Length (L)	53.3	69.8	69.8	86.3	86.3	86.3	86.3	102.8	102.8	102.8	102.8
重量 (滾珠軸承) Weight (g) /Ball bearings	1490	2120	2120	2750	2750	2750	2750	3380	3380	3380	3380

- 使用相對溼度：20%~85%RH  
Operating relative humidity
- 使用溫度範圍：-10°C~+60°C  
Operating temperature range

IG

# IG-90WGM

## 01 & 02 TYPE



Right Angle

### 外形尺寸/ Appearance Size

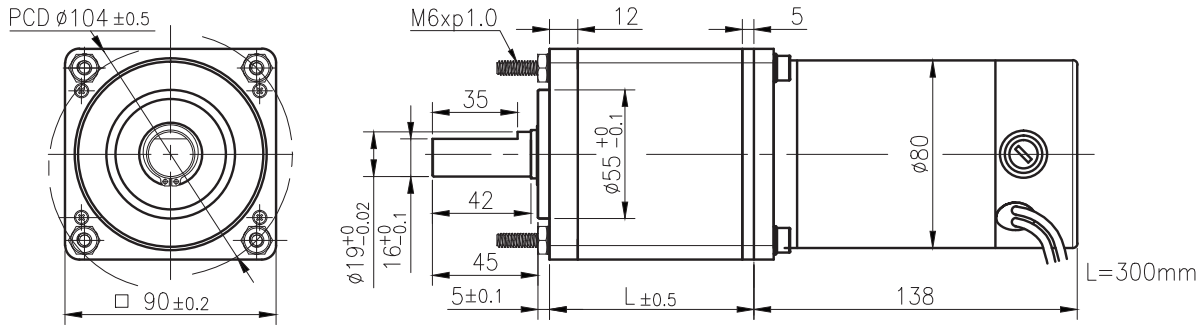

unit:mm

RA

### 齒輪箱馬達轉矩 & 速度/ Gear Motor Torque & Speed

		減速比 Reduction ratio	1/4	1/15	1/19	1/52	1/60	1/77	1/98	1/201	1/294	1/403	1/517
12V	定格扭力 Rated torque (kgf-cm)		7	25	32	78	89	115	147	180	180	180	180
	定格轉速 Rated speed (rpm)		470	115	90	32	28	22	17	8.8	6	4.5	3.6
24V	定格扭力 Rated torque (kgf-cm)		9	32	42	100	114	147	150	180	180	180	180
	定格轉速 Rated speed (rpm)		500	123	96	34	30	23	18.5	9.3	6.4	4.6	3.7
軸心迴轉方向 Rotation direction			CW										
長度 Length (L)			53.3	69.8		86.3				102.8			

RB

WG

### 馬達單體型式/ Motor Data

定格電壓 Rated volt (V)	定格扭力 Rated torque (gf-cm)	定格轉速 Rated speed (rpm)	定格電流 Rated current (A)	無負荷轉速 No load speed (rpm)	無負荷電流 No load current (A)	定格出力 Rated output (W)	重量 Weight (g)
12	2500	1700	≤ 5.3	2000	≤ 1.1	43.6	2150
24	3200	1800	≤ 3.7	2000	≤ 0.6	59	2150

PG

### 馬達單體特性/ Motor Characteristics

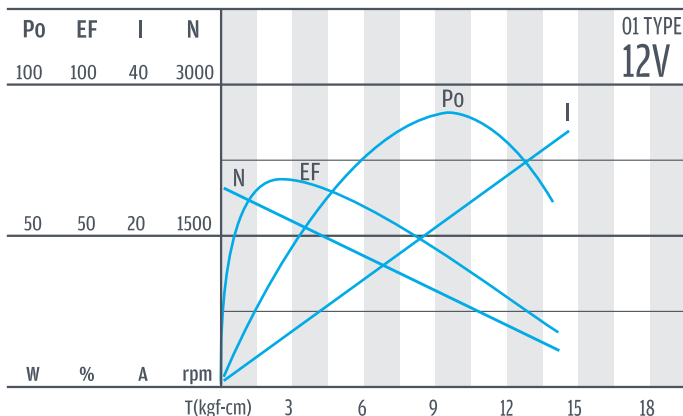

Encoder

Driver

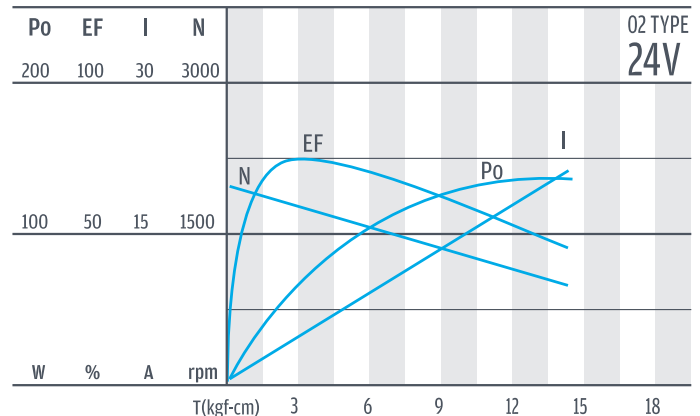

# IG-90WGM

## 41 TYPE



### 外形尺寸/ Appearance Size

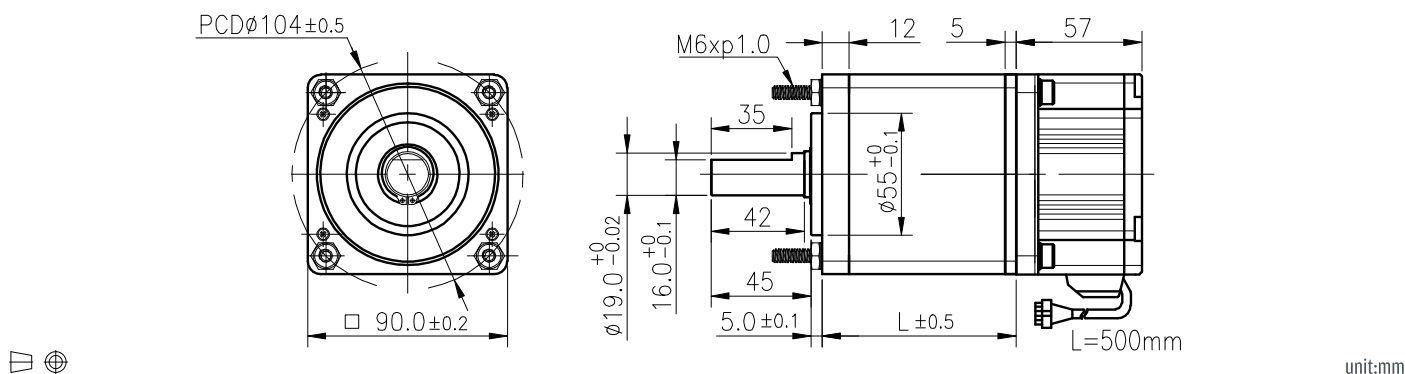

### 齒輪箱馬達轉矩 & 速度/ Gear Motor Torque & Speed

	減速比 Reduction ratio	1/4	1/15	1/19	1/52	1/60	1/77	1/98	1/201	1/294	1/403	1/517		
24V	定格扭力 Rated torque (kgf-cm)	11	40	52	125	143	150	150	180	180	180	180		
	定格轉速 Rated speed (rpm)	700	171	133	47	41.8	32.5	25.4	12	8.5	6.2	4.8		
	長度 Length (L)	53.3	69.8			86.3				102.8				

### 馬達單體型式/ Motor Data

定格電壓 Rated volt (V)	定格扭力 Rated torque (gf-cm)	定格轉速 Rated speed (rpm)	定格電流 Rated current (A)	無負荷轉速 No load speed (rpm)	無負荷電流 No load current (A)	定格出力 Rated output (W)	重量 Weight (g)
24	4000	2500	≤ 6	3000	≤ 0.6	102.7	1300
啟動扭力 Start torque (gf-cm)	絕緣抗耐 Insulation voltage	絕緣阻抗 Insulation resistance	絕緣等級 Insulation class	使用相對溼度 Operating relative humidity	使用溫度範圍 Operating temperature range		
5000	60HZ AC500V	100MΩ DC500V	A class (105°C)	20%~85%RH	0~+50°C		

### 馬達單體特性/ Motor Characteristics

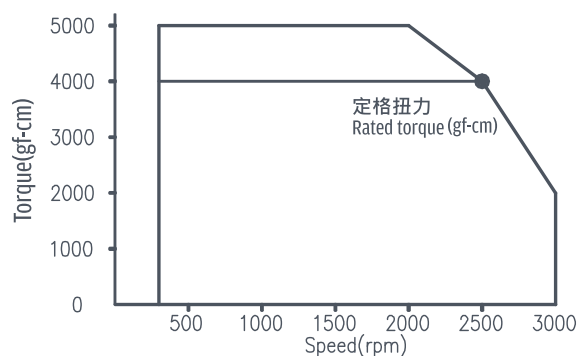

### 搭配之驅動器型式/ Connected With Motor Driver

型號 Type	DBMC100-3
輸入電壓 Input voltage	DC 24V±10%
速度控制範圍 Speed control range	300~3000 rpm
速度設定方式 Speed control way	1. 內部速度設定 Internal control 2. 外部速度設定 External speed control 3. 外部直流電壓控制 (DC 0~5V) External voltage control (DC 0~5V)

IG

# IG-90



Right Angle

## 外形尺寸 & 馬達齒鉚合尺寸 / Appearance Size & Pinion Assembly Dimension

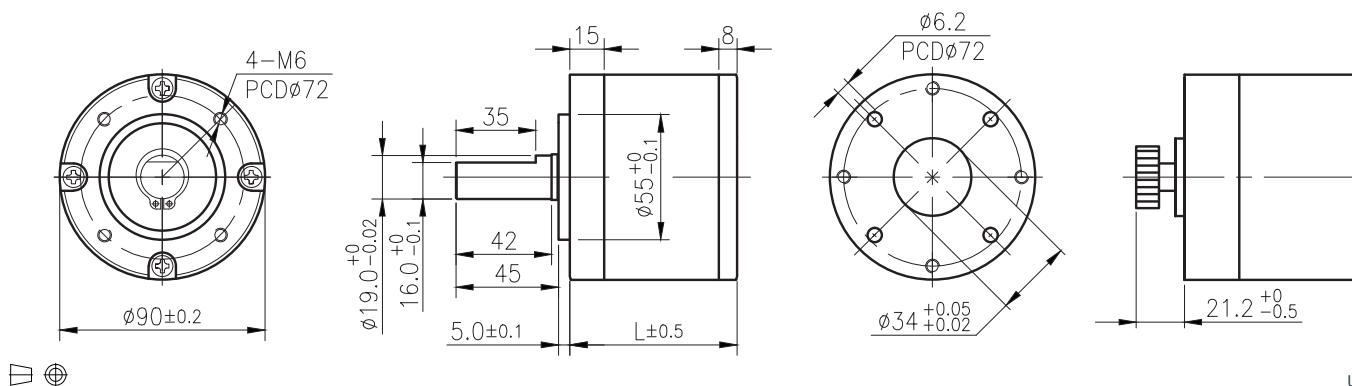

unit:mm

RA

RB

## 產品規格 / Product Specifications

外殼材質 Housing material	輸出軸承型式 Output shaft bearing	徑向負荷 Radial load (10mm from flange)	軸向負荷 Shaft axial load	主軸承受壓入力 Shaft press fit force	徑向間隙 Radial play of shaft	軸向間隙 Thrust play of shaft	背隙 (無負荷時) Backlash, at no-load
金屬 Metal	滾珠軸承 Ball bearings	≤ 40 kgf	≤ 10 kgf	≤ 100 kgf	≤ 0.08 mm	≤ 0.4 mm	≤ 4°

WG

## 馬達齒輪型式 / Pinion Specifications

模數 Module	齒數 No. of teeth	壓力角 Pressure angle	孔徑 (mm) Hole diameter	減速比 Reduction ratio
1.0	16	20°	○ $\phi 10 \times 8$	1/19, 1/77, 1/98, 1/294, 1/403, 1/517
1.0	22	20°	○ $\phi 12 \times 10$	1/15, 1/60
1.0	24	20°	○ $\phi 12 \times 10$	1/52, 1/201
1.25	21	20°	○ $\phi 12 \times 10$	1/4

PG

## 標準減速比型式 / Gearboxes Specifications

減速比 Reduction ratio	1/4	1/15	1/19	1/52	1/60	1/77	1/98	1/201	1/294	1/403	1/517
定格容許扭力 (kgf-cm max.) Rated tolerance torque	20	80	80	150	150	150	150	180	180	180	180
瞬間容許扭力 (kgf-cm) Max momentary tolerance torque	60	240	240	450	450	450	450	540	540	540	540
效率 Efficiency	80%	70%	70%	60%	60%	60%	60%	50%	50%	50%	50%
長度 Length (L)	57.3	73.8	73.8	90.3	90.3	90.3	90.3	106.8	106.8	106.8	106.8
重量 (滾珠軸承) Weight (g) / Ball bearings	1670	2230	2230	2800	2800	2800	2800	3370	3370	3370	3370

Encoder

Driver

- 使用相對溼度：20%~85%RH  
Operating relative humidity
- 使用溫度範圍：-10°C~+60°C  
Operating temperature range

# IG-90GM

## 01 & 02 TYPE



### 外形尺寸/ Appearance Size

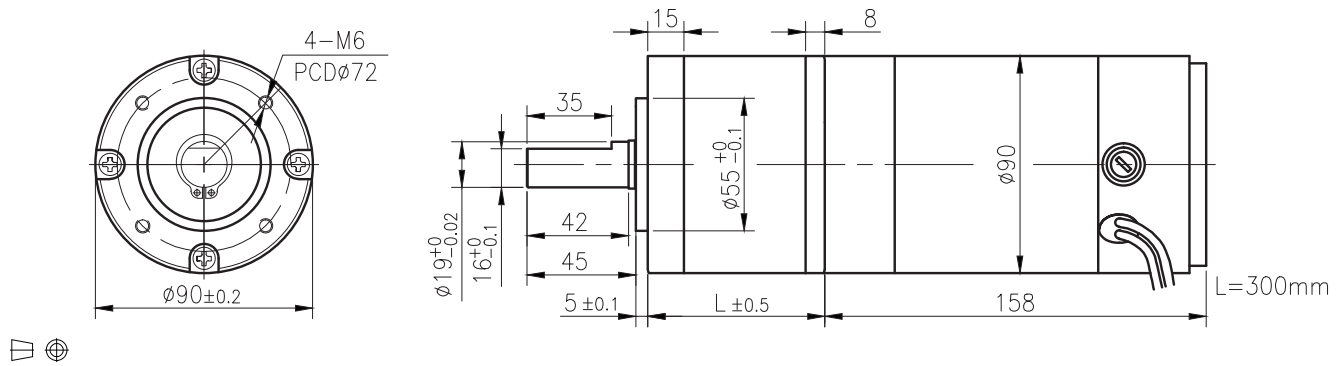

unit:mm

### 齒輪箱馬達轉矩 & 速度/ Gear Motor Torque & Speed

	減速比 Reduction ratio	1/4	1/15	1/19	1/52	1/60	1/77	1/98	1/201	1/294	1/403	1/517
12V	定格扭力 Rated torque (kgf-cm)	10	37	48	115	132	150	150	180	180	180	180
	定格轉速 Rated speed (rpm)	500	123	96	34	31	24	19	9.2	6.4	4.6	3.6
24V	定格扭力 Rated torque (kgf-cm)	12	42	55	130	150	150	180	180	180	180	180
	定格轉速 Rated speed (rpm)	510	127	99	35	31	25	20	9.4	6.5	4.7	3.7
	軸心迴轉方向 Rotation direction	CW										
	長度 Length (L)	57.3	73.8			90.3				106.8		

### 馬達單體型式/ Motor Data

定格電壓 Rated volt (V)	定格扭力 Rated torque (gf-cm)	定格轉速 Rated speed (rpm)	定格電流 Rated current (A)	無負荷轉速 No load speed (rpm)	無負荷電流 No load current (A)	定格出力 Rated output (W)	重量 Weight (g)
12	3700	1800	≤8.3	2000	≤1.5	68.4	2150
24	4200	1860	≤3.9	2000	≤0.95	80	2150

### 馬達單體特性/ Motor Characteristics

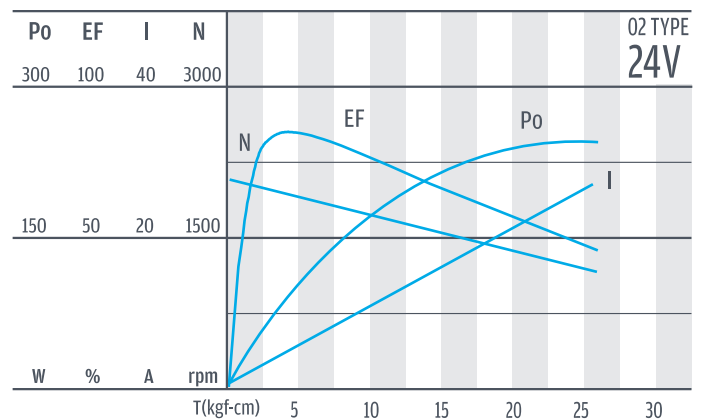
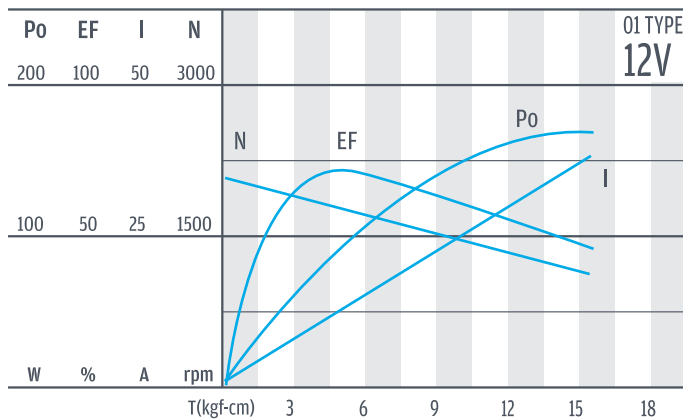





# IG-42CRGM

## 01 & 02 TYPE



### 外形尺寸/ Appearance Size

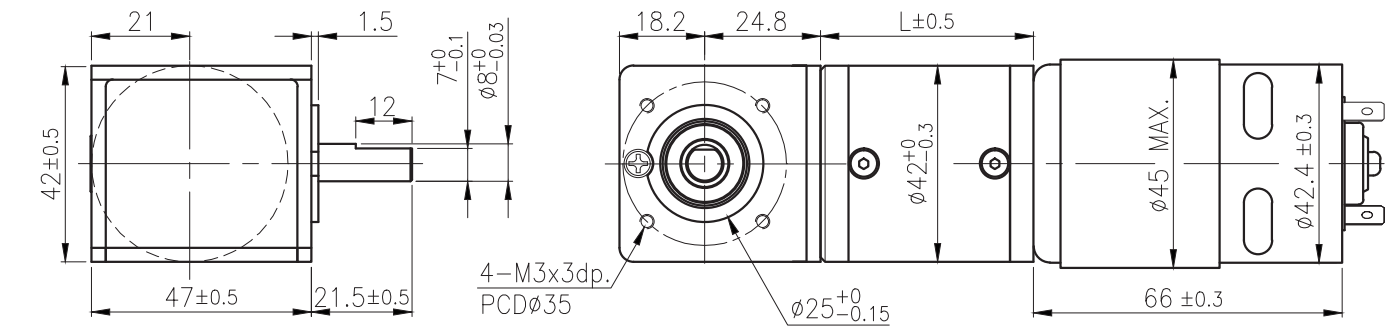

unit:mm

### 齒輪箱馬達轉矩 & 速度/ Gear Motor Torque & Speed

		1/4	1/14	1/17	1/24	1/49	1/61	1/84	1/104	1/144	1/212	1/294	1/504	1/624	1/720	1/864	1/1062	1/1470	1/2500	1/3000	1/3600	
12V	減速比 Reduction ratio																					
	定格扭力 Rated torque (kgf-cm)	2	6.1	7.6	8	18	18	18	20	20	25	25	30	30	30	30	30	30	30	30	30	30
24V	定格轉速 Rated speed (rpm)	1400	405	325	248	120	98	76	63	45	31	24	13.5	10.9	9.5	8	6.5	4.6	2.7	2.3	1.9	
	定格扭力 Rated torque (kgf-cm)	1.6	5	6.2	8	15	18	18	20	20	25	25	30	30	30	30	30	30	30	30	30	30
軸心迴轉方向 Rotation direction		CCW																				
長度 Length (L)		32.5	39.2		45.9				52.6				59.6									

### 馬達單體型式/ Motor Data

定格電壓 Rated volt (V)	定格扭力 Rated torque (gf-cm)	定格轉速 Rated speed (rpm)	定格電流 Rated current (A)	無負荷轉速 No load speed (rpm)	無負荷電流 No load current (A)	定格出力 Rated output (W)	重量 Weight (g)
12	700	5700	≤5.5	7000	≤0.9	41.3	360
24	570	5900	≤2.1	7000	≤0.5	34.7	360

### 馬達單體特性/ Motor Characteristics

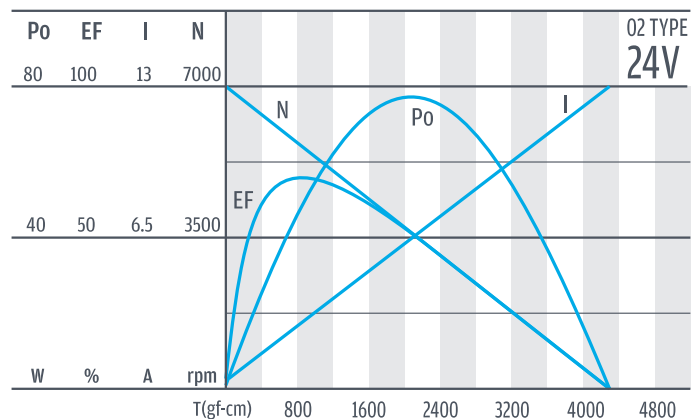
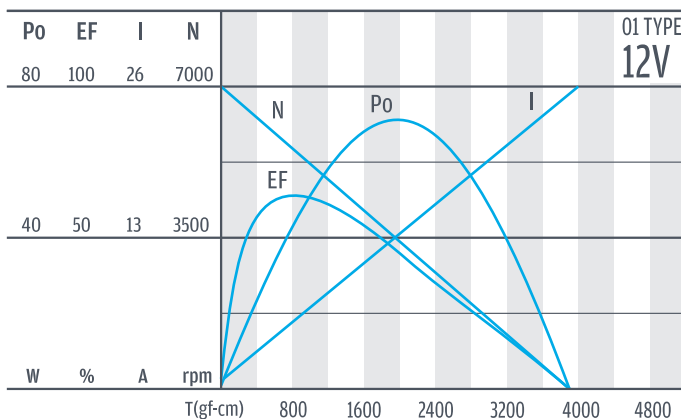

# IG-42CRGM

## 03 & 04 TYPE



IG

Right Angle

RA

### 外形尺寸/ Appearance Size

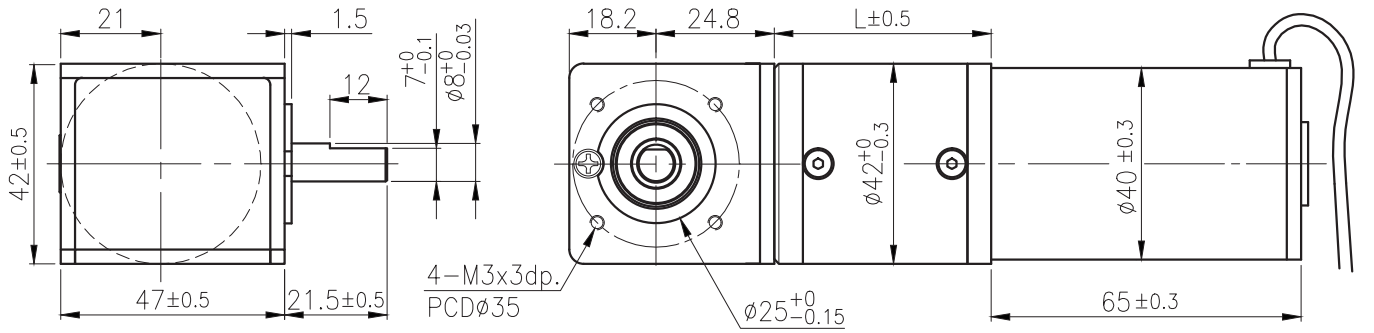

unit:mm

### 齒輪箱馬達轉矩 & 速度/ Gear Motor Torque & Speed

減速比 Reduction ratio	1/4	1/14	1/17	1/24	1/49	1/61	1/84	1/104	1/144	1/212	1/294	1/504	1/624	1/720	1/864	1/1062	1/1470	1/2500	1/3000	1/3600	
12V 定格扭力 Rated torque (kgf-cm)	1.2	3.8	4.7	6.5	11.3	14	18	20	20	25	25	30	30	30	30	30	30	30	30	30	
12V 定格轉速 Rated speed (rpm)	930	265	210	150	76	61	45	37	27	18.5	14	8.3	6.9	5.9	4.9	4	2.8	1.7	1.4	1.2	
24V 定格扭力 Rated torque (kgf-cm)	1	3	3.8	5.2	9.2	11.4	16	20	20	25	25	30	30	30	30	30	30	30	30	30	
24V 定格轉速 Rated speed (rpm)	945	270	215	155	76	62	45	36	27	18.5	14	8.3	6.9	5.9	4.9	4	2.8	1.7	1.4	1.2	
軸心迴轉方向 Rotation direction	CW																				
長度 Length (L)	32.5			39.2			45.9			52.6			59.6								

RB

WG

### 馬達單體型式/ Motor Data

定格電壓 Rated volt (V)	定格扭力 Rated torque (gf-cm)	定格轉速 Rated speed (rpm)	定格電流 Rated current (A)	無負荷轉速 No load speed (rpm)	無負荷電流 No load current (A)	定格出力 Rated output (W)	重量 Weight (g)
12	430	3750	≤ 2.0	4500	≤ 0.5	16.56	310
24	350	3800	≤ 0.82	4500	≤ 0.22	13.65	310

PG

### 馬達單體特性/ Motor Characteristics

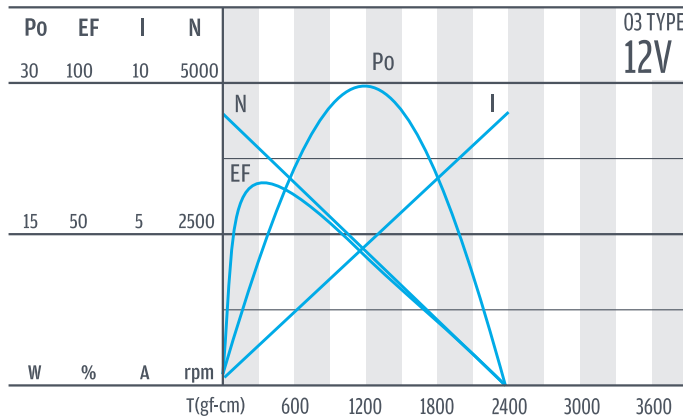

Encoder

Driver

